



گروه فنی مهندسی جوش و برش مقدم

اعتماد از شما کیفیت و تخصص از ما



09153223758



051-37581400



<https://www.moghadamwelding>



<http://instagram.com/moghadam>



<https://t.me/moghadamwelding>



<https://whatsapp.com/channel>



<https://rubika.ir/moghadamwelding>



مشهد خیام شمالی 63 خیابان پردیس 3

برای کسب اطلاعات بیشتر بر روی لینک ها کلیک کنید

- 7 سال سابقه آموزش تعمیرات تخصصی دستگاه های جوش اینورتری تک فاز و 3 فاز
- 7 سال سابقه فروش قطعات الکترونیکی دستگاه جوش تک فاز و 3 فاز
- آموزش تخصصی تحلیل دستگاه های جوش اینورتری مختص ابراز فروشان
- آموزش تخصصی ابراز آلات شارژی

特性 / FEATURES

- 30A触点切换能力
30A switching capability
- 线圈与触点间耐压为2kV
2kV dielectric strength
(between coil and contacts)
- 具有一组常开、常闭、转换触点形式
1 Form A, 1 Form B and 1 Form C configurations
- 可提供密封型或敞开型
Sealed type and open type available

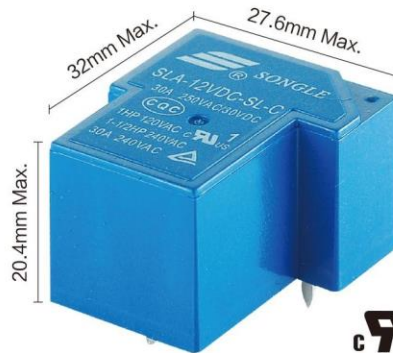

订购信息 / ORDERING INFORMATION

SLA-12VDC-S L-C

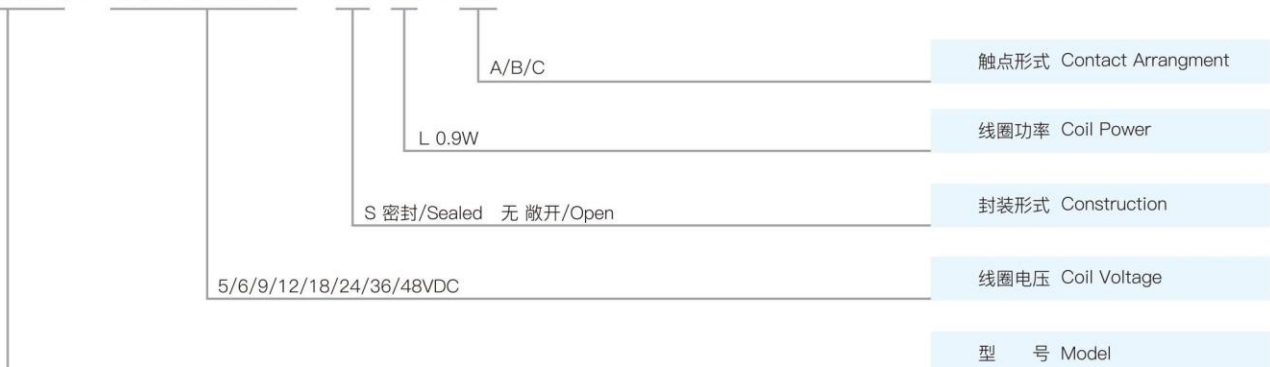

触点参数 / CONTACT PARAMETERS

触点形式	Contact arrangement	A, B, C
接触电阻	Contact resistance	≤100mΩ (1A 6VDC)
触点材质	Contact material	银合金/Silver alloy: AgSnO ₂ In ₂ O ₃ , AgSnO ₂ , AgNi
触点负载(阻性)	Contact rating(Res. load)	20A/30A 250VAC, 1-1/2HP 240VAC, 1HP 120VAC
最大切换电压	Max switching voltage	250VAC
最大切换电流	Max switching current	30A
最大切换功率	Max switching power	7500VA
电耐久性 (频率:每小时360次)	Electrical endurance (Frequency:360 ops/h)	1x10 ⁵ ops / 1x10 ⁴ ops
机械耐久性 (频率:每小时18000次)	Mechanical endurance (Frequency:18000 ops/h)	1x10 ⁷ ops

小型大功率继电器(6P)
Miniature High Power Relay

16A/20A/30A

特性参数 / CHARACTERISTICS PARAMETERS

绝缘等级	Insulation level			B/F
绝缘电阻	Insulation resistance			1000MΩ(500VDC)
介质耐压 (漏电流 1mA)	Dielectric strength (Leakage current 1mA)	线圈与触点间 Between coil and contacts	2000VAC 1min	
		断开触点间 Between open contacts	1500VAC 1min	
吸合时间(额定电压下)	Operate time(at nominal voltage)			≤15ms
释放时间(额定电压下)	Release time (without diode) (at nominal voltage)			≤10ms
湿度	Humidity			5% ~ 85% RH
环境温度(°C)	Ambient temperature			-40°C ~ +85°C/+105°C
抗冲击	Shock resistance	稳定性/Functional	98m/s ²	
		强度/Destructive	980m/s ²	
抗振动(双振幅)	Vibration resistance (Double amplitude)			10Hz~55Hz 1.5mm
重量	Weight			密封 约/Sealed approx 25g 敞开 约/Open approx 19g
封装形式	Construction			密封/Sealed 敞开/Open

备注: 以上数据均为初始值

Remark: All above data is initial value

线圈参数 / COIL PARAMETERS

常温/At (23°C)

功耗(W)	Power consumption(W)	0.9W(L)							
额定电压(VDC)	Nominal voltage(VDC)	05	06	09	12	18	24	36	48
线圈电阻(Ω±10%)	Coil resistance(Ω±10%)	27.7	40	90	160	360	640	1440	2560
吸合电压(Max)	Pick-up voltage(Max)	75% 额定电压(Nominal voltage)							
释放电压(Min)	Drop-out voltage(Min)	10% 额定电压(Nominal voltage)							
允许最大电压(VDC)	Max allowable overdrive voltage(VDC)	130% 额定电压(Nominal voltage)							

安全认证(相关认证以第三方认证证书为准) / SAFETY APPROVAL RATINGS

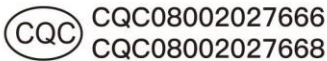

 30A 250VAC
20A 250VAC

 30A 250VAC
20A 250VAC

 30A 240VAC
20A 240VAC
1HP 16A 120VAC

外形图 / OUTLINE DIMENSIONS

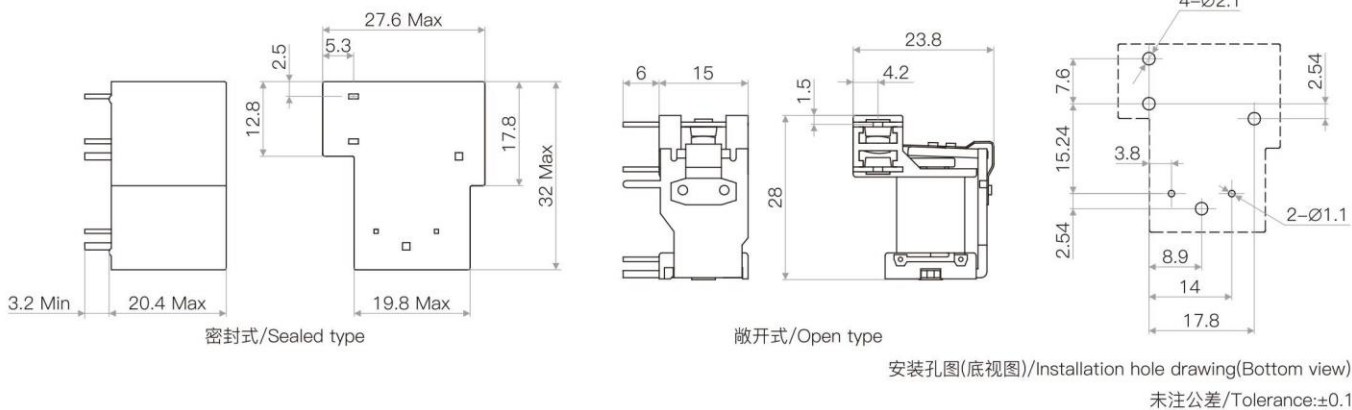
单位/Unit(mm)



线路图(底视图) / WIRING DIAGRAM (BOTTOM VIEW)

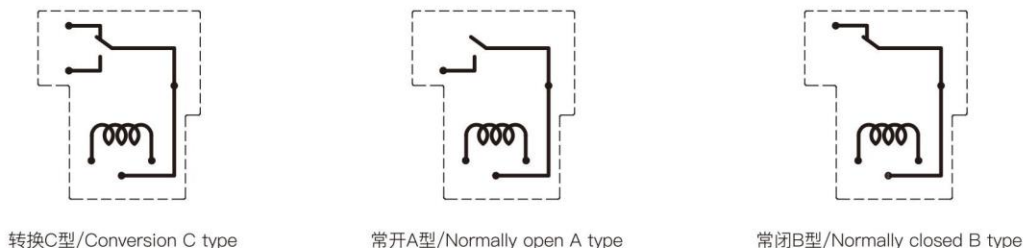

性能曲线图 / CHARACTERISTIC CURVES

