



گروه فنی مهندسی جوش و برش مقدم

اعتماد از شما کیفیت و تخصص از ما



09153223758



051-37581400



<https://www.moghadamwelding>



<http://instagram.com/moghadam>



<https://t.me/moghadamwelding>



<https://whatsapp.com/channel>



<https://rubika.ir/moghadamwelding>



مشهد خیام شمالی 63 خیابان پردیس 3

برای کسب اطلاعات بیشتر بر روی لینک ها کلیک کنید

- 7 سال سابقه آموزش تعمیرات تخصصی دستگاه های جوش اینورتری تک فاز و 3 فاز
- 7 سال سابقه فروش قطعات الکترونیکی دستگاه جوش تک فاز و 3 فاز
- آموزش تخصصی تحلیل دستگاه های جوش اینورتری مختص ابراز فروشان
- آموزش تخصصی ابراز آلات شارژی



Product Specification For Approval

Customer		
Approved Item	VDR-32D	
Customer P/N		
Lead form	<input checked="" type="checkbox"/> Straight <input type="checkbox"/> Crimped (mm) <input type="checkbox"/> Y Kink <input type="checkbox"/> Inner Crimped	
Packing	<input checked="" type="checkbox"/> Bulk <input type="checkbox"/> Ammo <input type="checkbox"/> Reel	
Approval Standard	E317616	ISO9001/2008
And File Number		
Standard	UL1449 TYPE 5	
Issue Data / REV	2018/9/20	A1
Special description		

SONGLONG LISHANG ELECTRONICS

DRAWN BY	CHECKED BY	APPROVAL BY
<i>Apple</i>	<i>Tony</i>	Simon Chien
Custome		
ACCEPT BYL	CHECKED BY	APPROVAL BY

Taiwan office	China Factory
康泰工业股份有限公司(原台湾嵩隆) Cerglass MFG Inc No.450,ZhongZhen 3rd RD., Yingge Dist., New Taipei City 23942, Taiwan (R.O.C.) 台湾省新北市莺歌区中正三路450号 TEL : 886-2-26797267 FAX : 886-2-26785358	惠州市嵩隆力上电子有限公司 HUIZHOU SHI SONGLONG LISHANG ELECTRONICS CO.,LTD Heng-Ling Developing Distict ,SatianTown, Hui-Yang,Hui-Zhou,Guang Dong Province, P.R.C. 惠州市惠阳区沙田镇田头横岭开发区 TEL:0752-3728085 FAX:0752-3728399



METAL OXIDE VARISTOR – 32D SERIES

FEATURES

- * Wide operating voltage (V1mA) range from 33V to 1600V.
- * Fast responding to transient over-voltage.
- * Large absorbing transient energy capability.
- * Low clamping ratio and no follow-on current.
- * Meets MSL level 1, per J-STD-020
- * Safety number :  E317616 ISO9001-2018

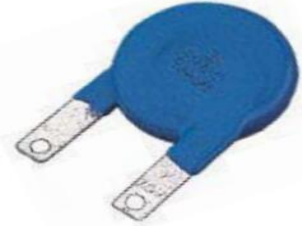

APPLICATION

- * Transistor, Diode, IC, Thyristor or Triac semiconductor protection.
- * Surge protection in consumer electronics.
- * Surge protection in industrial electronics.
- * Surge protection in electronic home appliances, gas and petroleum appliances.
- * Relay and electromagnetic valve surge absorption.



General Characteristics Definition

- * Operating Temperature: (-40 °C ~ +85 °C)
- * Storage Temperature: (-40 °C ~ +125 °C)
- * Working Surface Temperature: +115 °C
- * Insulation Resistance: > 100M Ω
- * Coating (Epoxy Resin): Flame-Retardant to UL 94 V-0

Material

- * Coating: Epoxy Resin
- * Lead Wire: The Copper Wire
- * Electrode: Silver Solder
- * Disk: Zinc Oxide

PART NUMBER CODE

VDR

Brand Mark

□ □

Element Diameter

D

Type: D: Disk , S: Square

□ □ □

Varistor Voltage

K

□ □

Sapce: Straight foot
Short leg : NO : □.□
CB: Outer bend
I: Inner bend
K: Small K foot
Y: High and low feet
J : High Surge
PH= Ultra Surge
TA : Ammo, TR : Reel
1□ = Combinatorial wave
2□ = Times
T & G is Horizontal patch

□

Tolerance : K±10%, L±15%

Sapce is 85 °C
"H" is 125 °C



PACKAGE DIENSIONS

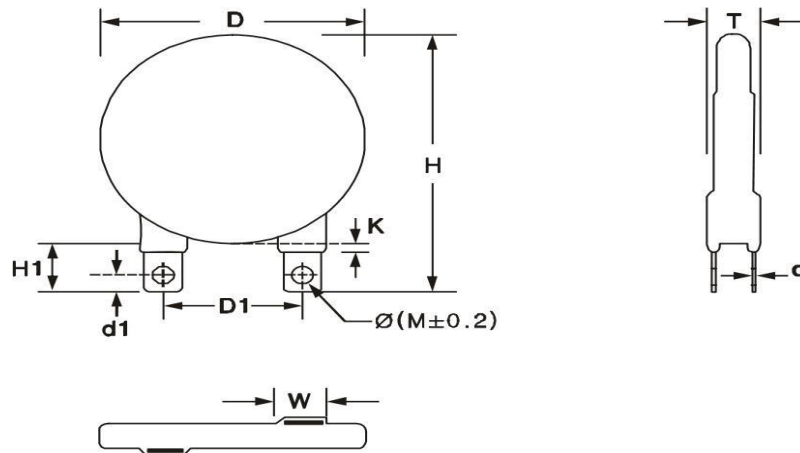

Part No.	T Max.	H(max.)	H1(min.)	D(max.)	D1(max.)	d(± 0.1)	d1(± 0.1)	K(max.)	W(± 0.1)	$\varnothing(M \pm 0.2)$
VDR-32D330K	6.0									
VDR-32D390K	6.2									
VDR-32D470K	6.4									
VDR-32D560K	6.7									
VDR-32D680K	7.0									
VDR-32D820K	5.7									
VDR-32D101K	5.8									
VDR-32D121K	6.0									
VDR-32D151K	6.3									
VDR-32D181K	6.1									
VDR-32D201K	6.2									
VDR-32D221K	6.3									
VDR-32D241K	6.4									
VDR-32D271K	6.8									
VDR-32D301K	6.9									
VDR-32D331K	6.9									
VDR-32D361K	7.1	56.3	14.5	38.0	25.4	0.5	3.7	3.2	7.0	3.2
VDR-32D391K	7.3									
VDR-32D431K	7.5									
VDR-32D471K	7.8									
VDR-32D511K	8.0									
VDR-32D561K	8.3									
VDR-32D621K	8.7									
VDR-32D681K	9.0									
VDR-32D751K	9.4									
VDR-32D781K	9.8									
VDR-32D821K	10.4									
VDR-32D911K	10.6									
VDR-32D102K	11.2									
VDR-32D112K	11.8									
VDR-32D122K	12.3									
VDR-32D142K	13.3									
VDR-32D162K	14.3									



ELECTRICAL CHARACTERISTIC

Part Number	Maximum Allowable Voltage		Varistor Voltage V1mA(V)	Maximum Clamping Voltage		Withstanding Surge Current I(A)	Energy 10/1000µS (J)	Typical Capacitance (Reference) @1KHzPF
	AC (V)	DC (V)		IP(A)	VC(V)			
32D330K	20	26	33(29.7~36.3)	40	65	10000	40	30000
32D390K	25	31	39(35.1~42.9)	40	77	10000	50	22000
32D470K	30	38	47(42.3~51.7)	40	93	10000	60	19000
32D560K	35	45	56(50.4~61.6)	40	110	10000	70	16700
32D680K	40	56	68(61.2~74.8)	40	135	10000	85	15000
32D820K	50	65	82(73.8~90.2)	200	135	22000	100	12800
32D101K	60	85	100(90~110)	200	165	22000	125	10500
32D121K	75	100	120(108~132)	200	200	22000	150	8700
32D151K	95	125	150(135~165)	200	250	22000	190	7000
32D181K	115	150	180(162~198)	200	300	30000	225	5800
32D201K	130	170	200(185~225)	200	330	30000	250	5200
32D221K	140	180	220(198~242)	200	360	30000	270	5150
32D241K	150	200	240(216~264)	200	395	30000	290	4880
32D271K	175	225	270(243~297)	200	455	30000	300	4550
32D301K	190	250	300(270~330)	200	505	30000	360	4300
32D331K	210	275	330(297~363)	200	550	30000	380	3900
32D361K	230	300	360(324~396)	200	595	30000	400	3200
32D391K	250	320	390(351~429)	200	650	30000	430	3100
32D431K	275	350	430(387~473)	200	710	30000	460	2800
32D471K	300	385	470(423~517)	200	775	30000	510	2700
32D511K	320	415	510(459~561)	200	845	30000	540	2550
32D561K	350	460	560(504~616)	200	920	30000	570	2400
32D621K	385	505	620(558~682)	200	1025	30000	600	2200
32D681K	420	560	680(612~748)	200	1120	30000	620	2000
32D751K	460	615	750(675~825)	200	1240	30000	660	1900
32D781K	485	640	780(702~858)	200	1290	30000	700	1800
32D821K	510	670	820(738~902)	200	1355	30000	750	1300
32D911K	550	745	910(819~1001)	200	1500	30000	780	1200
32D102K	625	825	1000(900~1100)	200	1650	30000	810	1100
32D112K	680	895	1100(990~1210)	200	1815	25000	910	1000
32D122K	750	990	1200(1080~1320)	200	1980	25000	960	920
32D142K	880	1140	1400(1260~1540)	200	2310	25000	1020	800
32D162K	1000	1280	1600(1400~1760)	200	2640	25000	1080	700

32D201K To 32D182K does have UL certification



Reliability Test

Mechanical Ratings

Test Parameter	Test Condition / Description			Performance Requirements
Terminal Pull Strength	After gradually applying the load specified below and keeping the unit fixed for ten seconds, the terminal shall be visually examined for any damage.	Diameter	Loading	No visible damage
		0.6mm	1.0 Kg	
		0.8mm	1.0 Kg	
		1.0mm	2.0 Kg	
Terminal Bending Strength	The unit shall be secured with its terminal kept vertical and the weight specified below be applied in the axial direction. The terminal shall gradually be bent by 90° in one direction, then 90° in the opposite direction, and again back to the original position. The damage of the terminal shall be visually examined.	Diameter	Loading	No visible damage
		0.6mm	0.5 Kg	
		0.8mm	0.5 Kg	
		1.0mm	1.0 Kg	
Vibration	The Specimen shall be vibrated by its lead wires with a total amplitude of 1.5mm and a varying frequency of 10~55~10HZ(each minutes) for a period of 2 hours respectively in each X,Y and Z directions.			No visible damage $\Delta VB/VB\% \leq \pm 5\%$
Soldering-solderability	After dipping the terminal to depth of approximately 3mm from the specimen in a soldering bath of 260°C for 10±1(D5: 5±1) seconds. Thereafter the terminal shall be visually examined.			Terminations shall be uniformly tinned
Soldering-Resistance to Solder Heat	After preheating the specimen, the specimen shall be completely immersed into a soldering bath having a temperature of 260±5°C for 10±1 (D5: 5±1) seconds or iron of 400±5°C for 3±0.5 seconds. There after the change of Vb and mechanical damage shall be examined.			No visible damage $\Delta VB/VB\% \leq \pm 5\%$

ENVIRONMENTAL RATINGS

Dry Heat Loading	The specimen shall be applied continuously the maximum allowable voltage at the specified conditions for specified period and then stored at room temperature and normal humidity over 2 hours. Thereafter, the change of Vb and mechanical damage shall be examined. temp: 125±2°C ; Period: 1000±24hours.			$\Delta VB/VB\% \leq \pm 10\%$	
High Temperature Storage	In a drying oven without load. Ambient temp: 125±2°C ; period: 1000±24hours			$\Delta VB/VB\% \leq \pm 5\%$	
Damp Heat Loading	The specimen shall be applied continuously the maximum allowable voltage at the specified conditions for specified period and then stored at room temperature and normal humidity over 2 hours. Thereafter, the change of Vb and mechanical damage shall be examined. condition: 40±2°C , 90 to 95%R.H. ; period: 1000±24 hours			$\Delta VB/VB\% \leq \pm 10\%$	
Temperature Cycle	Condition the specimen to each temperature form step 1 to step 4 in this order for the period shown in the table of specifications. The change of Vb and mechanical damage shall be examined after 2 hours.	Step	Temp°C	Period	No visible damage $\Delta VB/VB\% \leq \pm 10\%$
		1	-40±3°C	30 min.	
		2	Room Temp	15 min.	
		3	85±2°C	30 min.	
		4	Room Temp	15 min.	
Surge Lifetime Rating	The change of Vb shall be measured after the impulse listed below is applied 10,000 times continuously with the interval of ten seconds at room temperature.			No visible damage $\Delta VB/VB\% \leq \pm 10\%$	
Voltage Proof	Voltage: 2500VAC Leakage Current ≤ 0.5mA Time: 60 Seconds			No Breakdown	

MARKING CODE

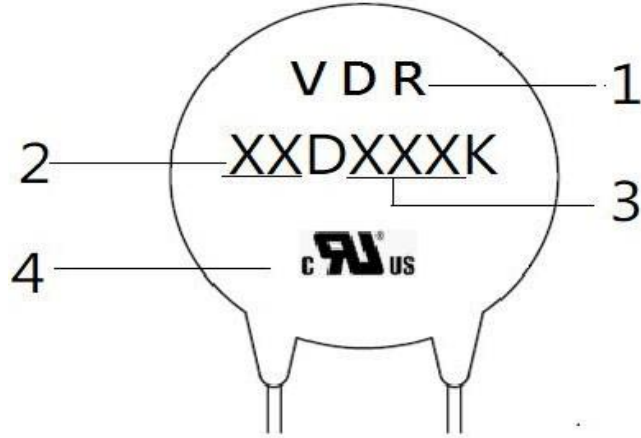

- 1 SongLong Lishang Logo
- 2 Disk Size
- 3 Varistor Voltage
- 4  Accreditation Logo

Packaging specification / bulk packaging quantity

Unit:Pcs

Dimension	Part No.	Bag	Small Carton	Carton
25D	180L to 182K	100	600	1,200
25D (Short leg)	180L to 182K	100	800	1,600