



گروه فنی مهندسی جوش و برش مقدم

اعتماد از شما کیفیت و تخصص از ما



09153223758



051-37581400



<https://www.moghadamwelding>



<http://instagram.com/moghadam>



<https://t.me/moghadamwelding>



<https://whatsapp.com/channel>



<https://rubika.ir/moghadamwelding>



مشهد خیام شمالی 63 خیابان پردیس 3

برای کسب اطلاعات بیشتر بر روی لینک ها کلیک کنید

- 7 سال سابقه آموزش تعمیرات تخصصی دستگاه های جوش اینورتری تک فاز و 3 فاز
- 7 سال سابقه فروش قطعات الکترونیکی دستگاه جوش تک فاز و 3 فاز
- آموزش تخصصی تحلیل دستگاه های جوش اینورتری مختص ابراز فروشان
- آموزش تخصصی ابراز آلات شارژی

Fixed Frequency Current Mode PWM Controller**DESCRIPTION**

UC3843 is a fixed frequency current-mode PWM controller. It is specially designed for Off Line and DC-to-DC converter applications with minimal external component. This integrated circuit features a trimmed oscillator for precise duty cycle control, a temperature compensated reference, a high gain error amplifier, a current sensing comparator, and a high current totem pole output ideally suited for driving a power MOSFET.

The device is protective features consisting of input and reference under-voltage lockouts each with hysteresis, cycle-by-cycle current limiting.

FEATURES

- Automatic Feed Forward Compensation
- High Current Totem Pole Output
- Internally Trimmed Bandgap Reference
- Undervoltage Lockout with Hysteresis
- Low Start Up Current
- Optimized for offline converter
- Double pulse suppression
- Current mode operation to 500kHz

APPLICATION

- Wireless Base Station Power
- Telecom and Datacom Power
- Industrial Power Systems
- PC Power Supplies

ORDERING INFORMATION

Temperature Range	Package		Orderable Device	Package Qty
0°C to +70°C	DIP8L	Pb-Free	UC3843D	75Units/Tube
	SOP8L		UC3843P	50Units/Tube

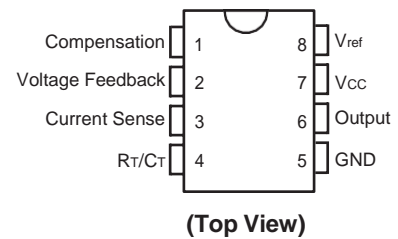
PIN CONFIGURATION

SCHEMATIC DIAGRAM

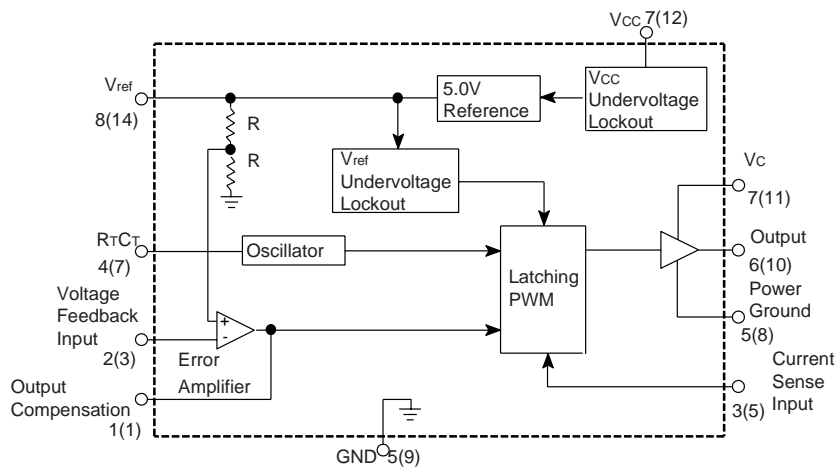

Pin numbers in parenthesis are for the D suffix SOIC-14 package.

Figure 1. Simplified Block Diagram

PIN DESCRIPTION

No.	Name	Function Description
1	Compensation	This pin is the Error Amplifier output and is made available for loop compensation.
2	Voltage Feedback	This is the inverting input of the Error Amplifier. It is normally connected to the switching power supply output through a resistor divider.
3	Current Sense	A voltage proportional to inductor current is connected to this input. The PWM uses this information to terminate the output switch conduction.
4	R _T /C _T	The Oscillator frequency and maximum Output duty cycle are programmed by connecting resistor R _T to V _{REF} and capacitor C _T to ground. Operation to 500kHz is possible.
5	GND	This pin is the combined control circuitry and power ground.
6	Output	This output directly drives the gate of a power MOSFET. Peak currents up to 1.0A are sourced and sunk by this pin.
7	V _{CC}	This pin is the positive supply of the control IC.
8	V _{REF}	This is the reference output. It provides charging current for capacitor C _T through resistor R _T .

ABSOLUTE MAXIMUM RATINGS

Parameter	Symbol	Value	Unit
Total Power Supply and Zener Current	$I_{CC} + I_Z$	30	mA
DC Supply Voltage	V_{CC}	30	V
Output Current	I_O	± 1.0	A
Output Energy (Capacitive Load per Cycle)	W	5.0	μJ
Error Amp Output Sink Current	I_{OE}	10	mA
Current Sense and Voltage Feedback Inputs	V_{IN}	-0.3 to 5.5	V
Maximum Power Dissipation @ $T_A = 25^\circ C$	P_D	0.862	W
Thermal Resistance, Junction-to-Air	R_{BIA}	145	$^\circ C/W$
Maximum Operating Junction Temperature	T_J	+150	$^\circ C$
Storage Temperature Range	T_{STG}	-65 to +150	$^\circ C$

RECOMMENDED OPERATION CONDITIONS

Parameter	Symbol	Min	Max	Unit
DC Supply Voltage	V_{CC}	12	25	V
Operating Temperature	T_A	0	70	$^\circ C$

ELECTRICAL CHARACTERISTICS

($V_{CC} = 15V$ unless otherwise noted)

Parameter	Symbol	Test Conditions	Min	Max	Unit
Reference Section					
Reference Out	V_{REF}	$I_O = 1.0mA, V_{CC} = 15V, T_A = 25 \pm 10^\circ C$	4.9	5.1	V
		$I_O = 1.0mA, V_{CC} = 15V, T_A = T_{LOW} \text{ to } T_{HIGH}$	4.865	5.135	
Line Regulation	Reg_{LINE}	$V_{CC} = 12V \text{ to } 25V, T_A = T_{LOW} \text{ to } T_{HIGH}$		20	mV
Load Regulation	Reg_{LOAD}	$I_O = 1.0 \text{ to } 20mA, T_A = T_{LOW} \text{ to } T_{HIGH}$		25	mV
Total Output Variation over Line, Load, Temperature (Note1)	V_{FINAL}	$V_{CC} = 12V, I_O = 1.0mA, T_A = T_{LOW} \text{ to } T_{HIGH}$	4.82	5.18	V
		$V_{CC} = 25V, I_O = 20mA, T_A = T_{LOW} \text{ to } T_{HIGH}$			
Output Short Circuit Current	I_{SC}	$V_{CC} = 15V$	-30	-180	mA



ELECTRICAL CHARACTERISTICS

Parameter	Symbol	Test Conditions	Min	Max	Unit	
Oscillator Section						
Frequency	f_{osc}	$V_{CC} = 15V, T_J = 25^\circ C$ $R_T = 10K\Omega, C_T = 3.3nF$	47	57	kHz	
		$V_{CC} = 15V,$ $T_A = T_{LOW} \text{ to } T_{HIGH},$ $R_T = 10K\Omega, C_T = 3.3nF$	46	60		
Frequency Change with Voltage	$\Delta f_{osc}/\Delta V$	$V_{CC} = 12V \text{ to } 25V,$ $T_A = T_{LOW} \text{ to } T_{HIGH},$ $R_T = 10k\Omega, C_T = 3.3nF$		1.0	%	
Discharge Current	I_{disch}	$V_{osc} = 2.0V$ $V_{CC} = 15V$	$T_J = 25^\circ C$	7.5	9.3	mA
			$T_A = T_{LOW} \text{ to } T_{HIGH}$	7.2	9.5	
Error Amplifier Section						
Voltage Feedback Input	V_{FB}	$V_O = 2.5V, V_{CC} = 15V,$ $T_A = T_{LOW} \text{ to } T_{HIGH}$	2.42	2.58	V	
Input Bias Current	I_{IB}	$V_{FB} = 2.7V, V_{CC} = 15V,$ $T_A = T_{LOW} \text{ to } T_{HIGH}$		-2.0	μA	
Open Loop Voltage Gain	A_{VOL}	$V_O = 2.0V \text{ to } 4.0V,$ $V_{CC} = 15V,$ $T_A = T_{LOW} \text{ to } T_{HIGH}$	65		dB	
Unity Gain Bandwidth	BW	$V_{CC} = 15V,$ $T_A = T_{LOW} \text{ to } T_{HIGH}$	0.7		MHz	
Power Supply Rejection Ratio	PSRR	$V_{CC} = 12V \text{ to } 25V,$ $T_A = T_{LOW} \text{ to } T_{HIGH}$	60		dB	
Output Current	Sink	I_{SINK} $V_O = 1.1V, V_{FB} = 2.7V,$ $V_{CC} = 15V,$ $T_A = T_{LOW} \text{ to } T_{HIGH}$	2.0		mA	
	Source	I_{SOURCE} $V_O = 5.0V, V_{FB} = 2.3V,$ $V_{CC} = 15V,$ $T_A = T_{LOW} \text{ to } T_{HIGH}$	-0.5			
Output Voltage Swing	High State	V_{OH} $V_{FB} = 2.7V, V_{CC} = 15V$ $R_{L(GND)} = 15K\Omega,$ $T_A = T_{LOW} \text{ to } T_{HIGH}$	5.0		V	
	Low State	V_{OL} $V_{FB} = 2.7V, V_{CC} = 15V$ $R_{L(5.0)} = 15K\Omega,$ $T_A = T_{LOW} \text{ to } T_{HIGH}$		1.1		

ELECTRICAL CHARACTERISTICS(CONTINUE)

Parameter	Symbol	Test Conditions	Min	Max	Unit
Current Sense Section					
Current Sense Input Voltage Gain	A_V	$V_{FB} = 0V, V_{CC} = 15V,$ $T_A = T_{LOW} \text{ to } T_{HIGH}$	2.85	3.15	
Maximum Current Sense Input Threshold	V_{TH}	$V_{FB} = 0V, V_{CC} = 15V,$ $T_A = T_{LOW} \text{ to } T_{HIGH}$	0.9	1.1	V
Input Bias Current	I_{IB}	$V_{CC} = 15V,$ $T_A = T_{LOW} \text{ to } T_{HIGH}$		-10	μA
Propagation Delay (Current Sense Input to Output)	t_{PLH}	$V_{CC} = 15V,$ $T_A = T_{LOW} \text{ to } T_{HIGH}$		300	ns

Output Section

Output Voltage	Low State	V_{OL}	$I_{SINK} = 20mA, V_{CC} = 15V$		0.4	V
			$I_{SINK} = 200mA, V_{CC} = 15V$		2.2	
	High State	V_{OH}	$I_{SINK} = 20mA, V_{CC} = 15V$	13		
			$I_{SINK} = 200mA, V_{CC} = 15V$	12		
Output Voltage with UVLO Activated	$V_{OL(UVLO)}$	$V_{CC} = 6V, I_{SINK} = 1.0mA,$ $T_A = T_{LOW} \text{ to } T_{HIGH}$		1.1	V	
Output Voltage Rise Time	t_r	$C_L = 1.0nF, V_{CC} = 15V,$ $T_A = T_{LOW} \text{ to } T_{HIGH}$		150	ns	
Output Voltage Fall Time	t_f	$C_L = 1.0nF, V_{CC} = 15V,$ $T_A = T_{LOW} \text{ to } T_{HIGH}$		150	ns	

Under Voltage Lockout Section

Startup Threshold	V_{th}	$V_{CC} = 0V \text{ to } 25V,$ $T_A = T_{LOW} \text{ to } T_{HIGH}$	7.8	7.9	V
Minimum Operating Voltage After Turn-On	$V_{CC(MIN)}$	$V_{CC} = 0V \text{ to } 25V,$ $T_A = T_{LOW} \text{ to } T_{HIGH}$	7.0	8.2	V

PWM Section

Duty Cycle	DC	$V_{CC} = 15V,$ $T_A = T_{LOW} \text{ to } T_{HIGH},$ $R_T = 10K\Omega, C_T = 3.3nF$	0	94	%
------------	----	--	---	----	---

Total Device

Power Supply Current	I_{CC}	Startup: $V_{CC} = 14V$		1.0	mA
		Operating: $V_{CC} = 15V$		17	
Power Supply Zener Voltage	V_Z	$I_{CC} = 25mA, V_{CC} = 0 \text{ to } 40V$	30	40	V

Note 1: $V_{FINAL} = V_{REF25}(Reg_{LINE} + Reg_{LOAD})/1000 \pm |V_{REF70}(V_{REF0}) - V_{REF25}|$ $V_{REF25} = V_{REF} @ T_A = 25^\circ C;$
 $V_{REF70} = V_{REF} @ T_A = 70^\circ C; V_{REF0} = V_{REF} @ T_A = 0^\circ C.$

Note 2: $T_{LOW} = 0^\circ C, T_{HIGH} = +70^\circ C$



TYPICAL PERFORMANCE CHARACTERISTICS

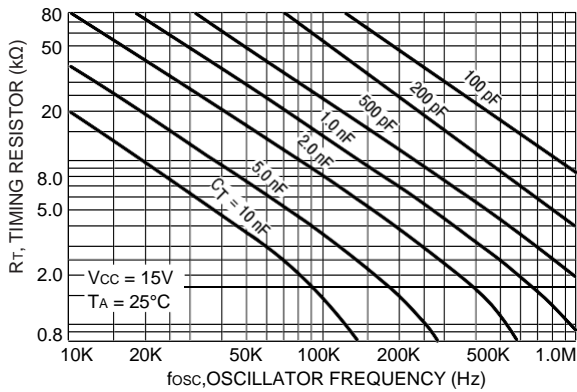

Figure 2. Timing Resistor versus Oscillator Frequency

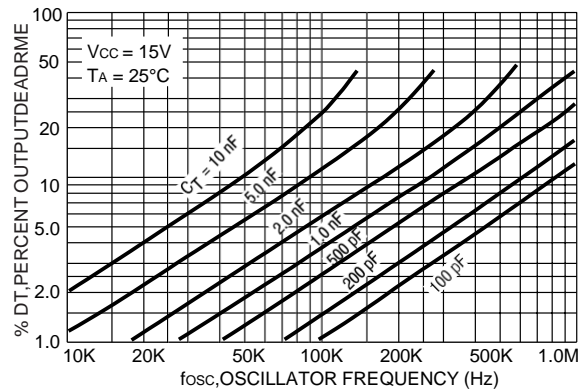

Figure 3. Output Deadtime versus Oscillator Frequency

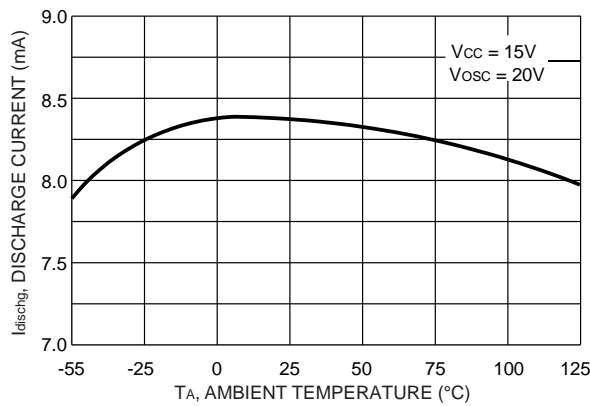

Figure 4. Oscillator Discharge Current versus Temperature

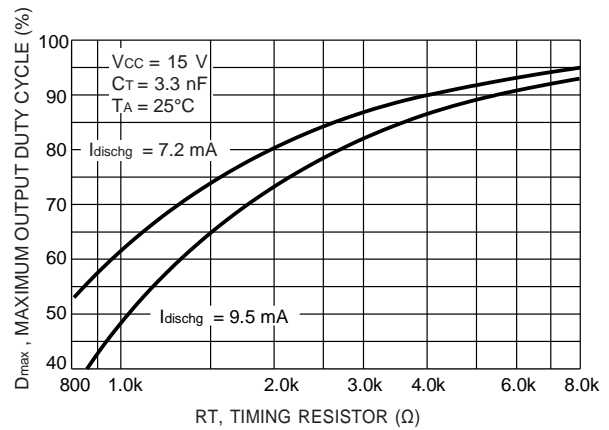

Figure 5. Maximum Output Duty Cycle versus Timing Resistor

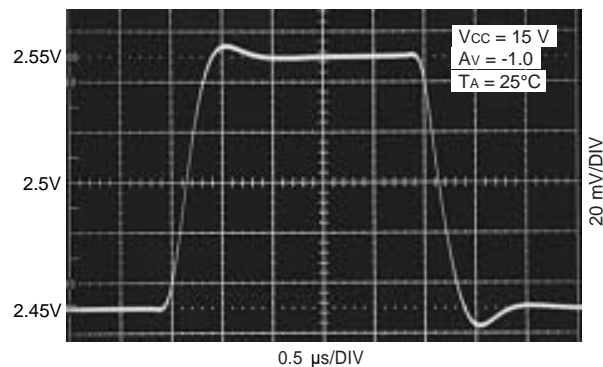

Figure 6. Error Amp Small Signal Transient Response

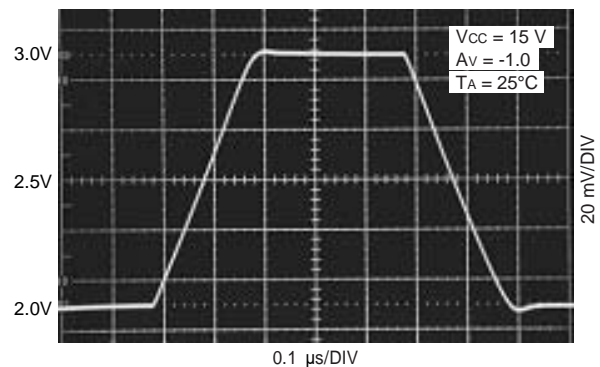

Figure 7. Error Amp Large Signal Transient Response

TYPICAL PERFORMANCE CHARACTERISTICS(CONTINUE)

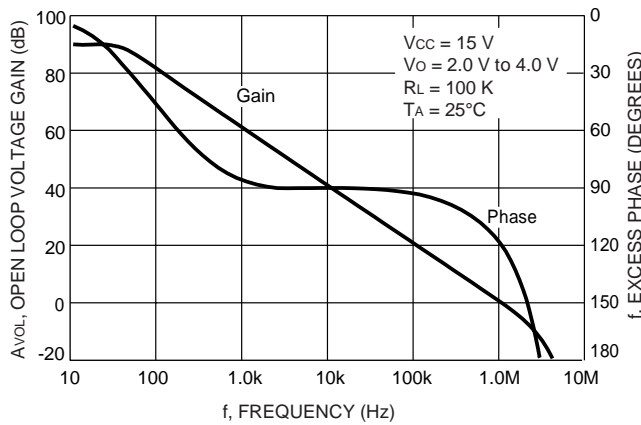

Figure 8. Error Amp Open Loop Gain and Phase versus Frequency

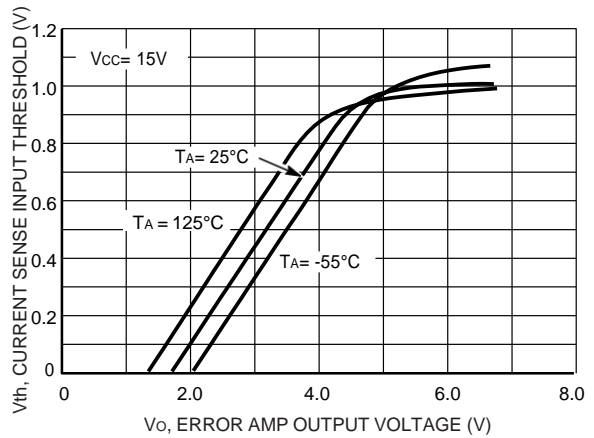

Figure 9. Current Sense Input Threshold versus Error Amp Output Voltage

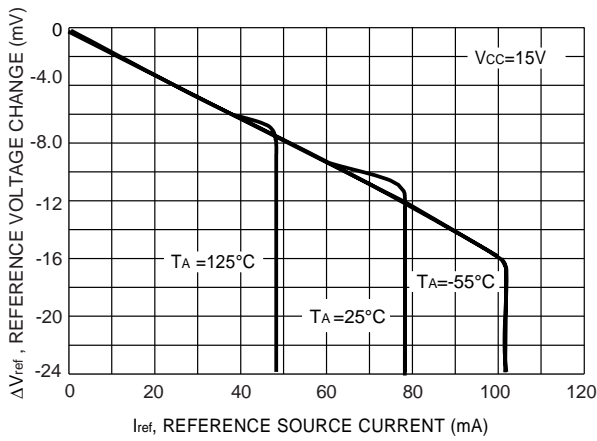

Figure 10. Reference Voltage Change versus Source Current

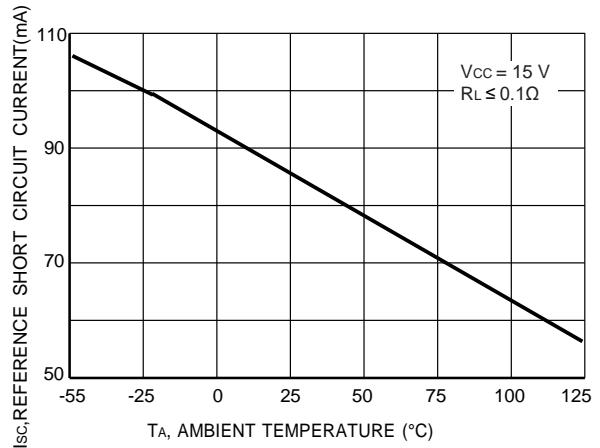

Figure 11. Reference Short Circuit Current versus Temperature

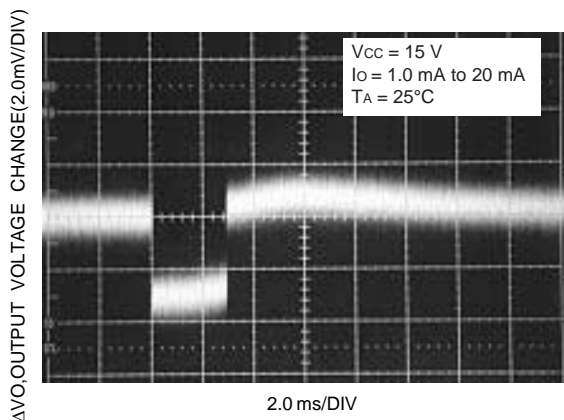

Figure 12. Reference Load Regulation

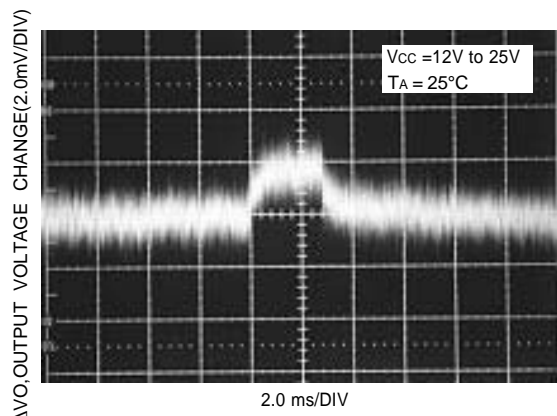

Figure 13. Reference Line Regulation

TYPICAL PERFORMANCE CHARACTERISTICS(CONTINUED)

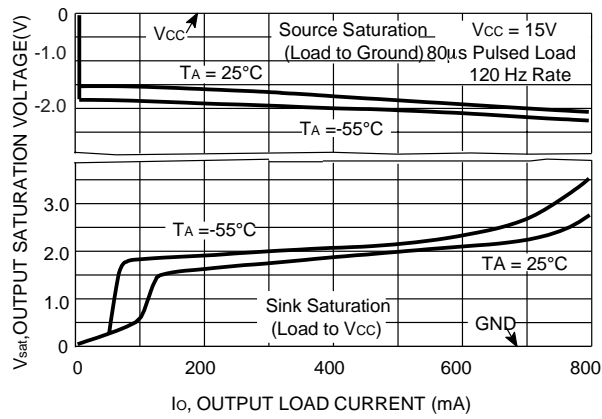

Figure 14. Output Saturation Voltage versus Load Current

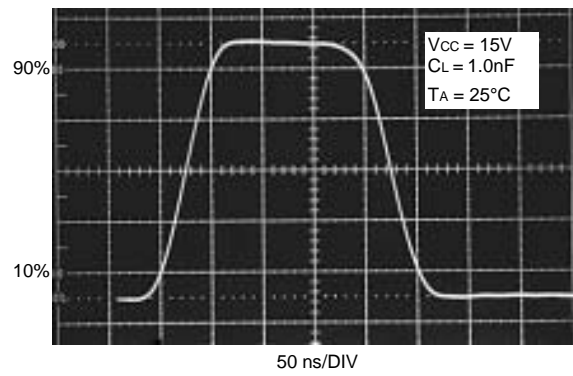

Figure 15. Output Waveform

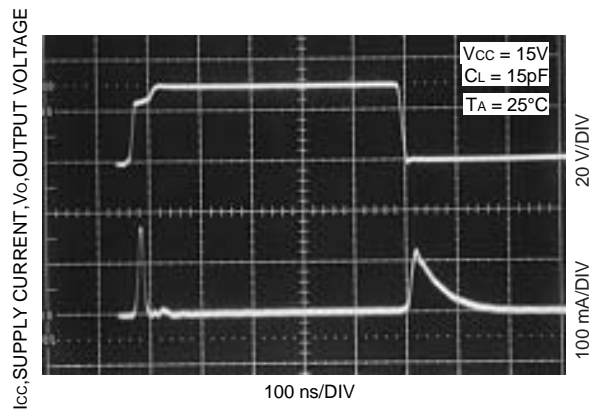

Figure 16. Output Cross Conduction

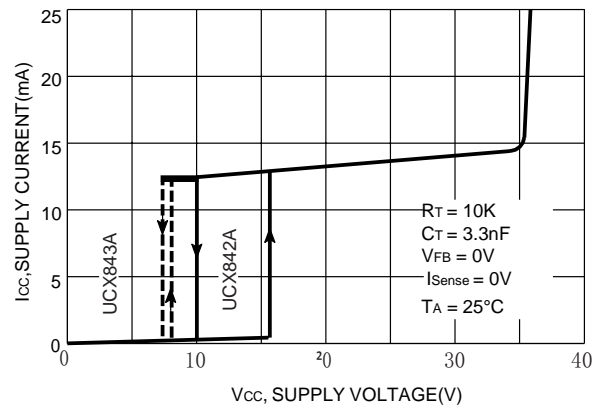
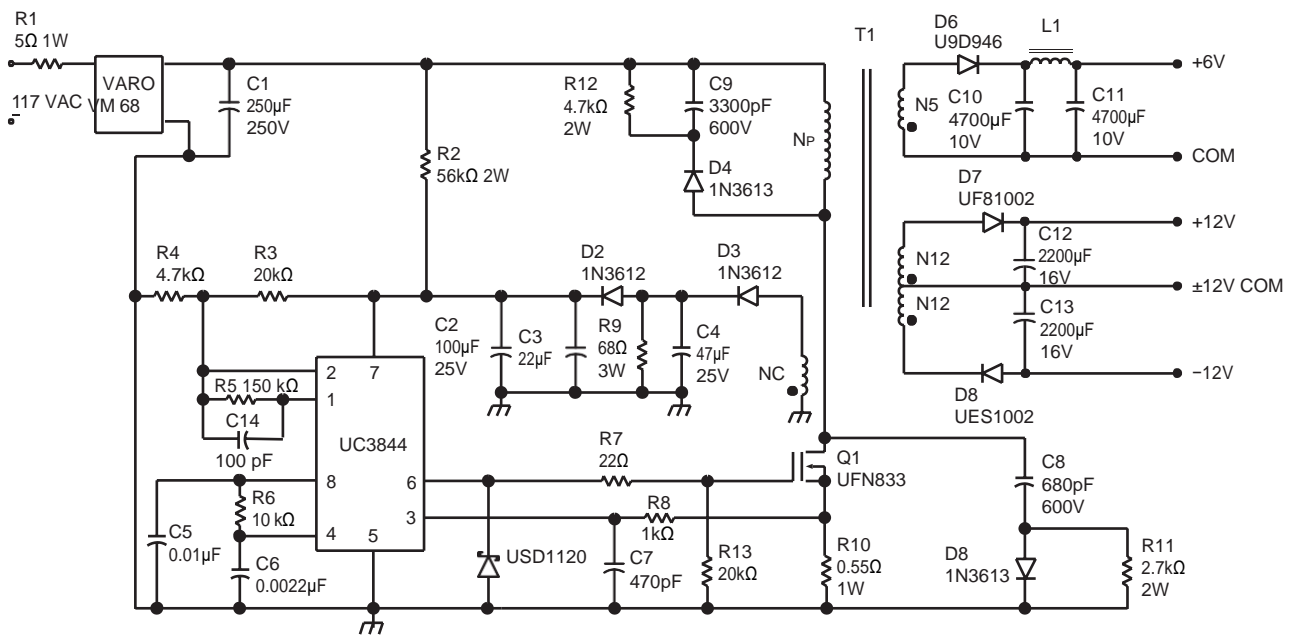
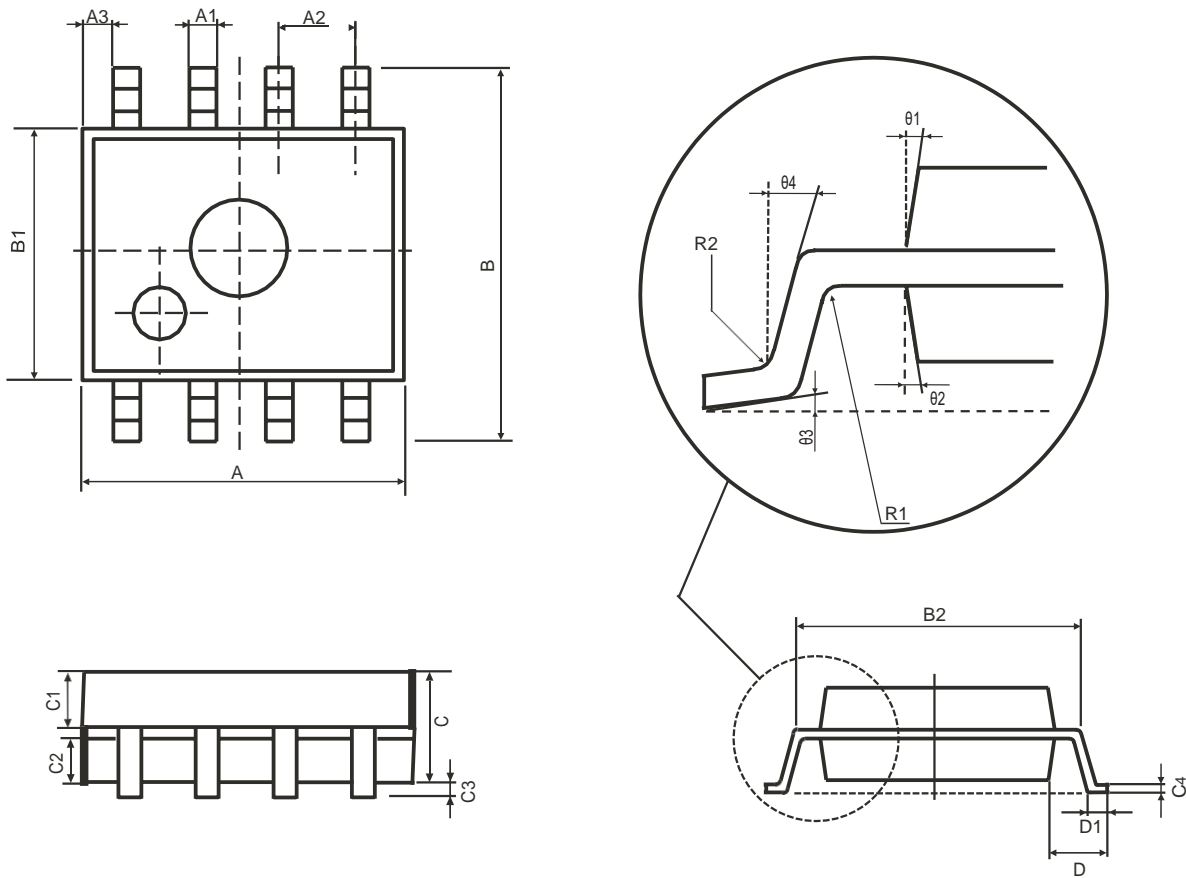

Figure 17. Supply Current versus Supply Voltage

TYPICAL APPLICATION



PHYSICAL DIMENSIONS SOP8L



Symbol	Dimension(mm)		Symbol	Dimension(mm)	
	Min	Max		Min	Max
A	4.95	5.15	C3	0.05	0.20
A1	0.37	0.47	C4	0.20(TYP)	
A2	1.27(TYP)		D	1.05(TYP)	
A3	0.41(TYP)		D1	0.40	0.60
B	5.80	6.20	R1	0.07(TYP)	
B1	3.80	4.00	R2	0.07(TYP)	
B2	5.0(TYP)		θ1	17°(TYP)	
C	1.30	1.50	θ2	13°(TYP)	
C1	0.55	0.65	θ3	4°(TYP)	
C2	0.55	0.65	θ4	12°(TYP)	

DIP8L

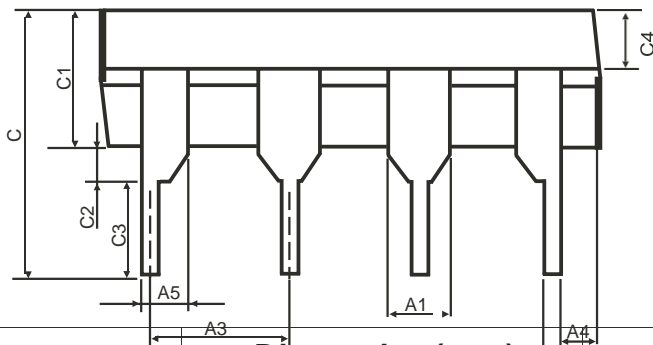
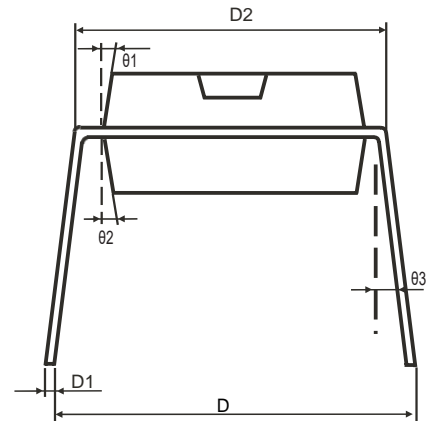
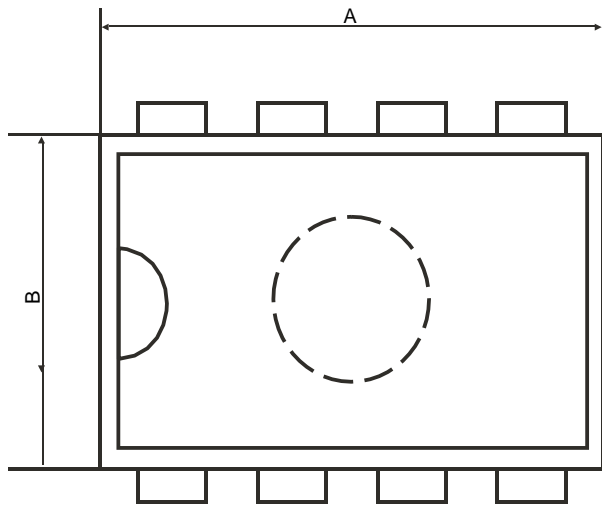

Symbol	Dimension(mm)		Symbol	Dimension(mm)	
	Min	Max		Min	Max
A	9.30	9.50	C2	0.5(TYP)	
A1	1.524(TYP)		C3	3.3(TYP)	
A2	0.39	0.53	C4	1.57(TYP)	
A3	2.54(TYP)		D	8.20	8.80
A4	0.66(TYP)		D1	0.20	0.35
A5	0.99(TYP)		D2	7.62	7.87
B	6.3	6.5	1	8 (TYP)	
C	7.20(TYP)		2	8 (TYP)	
C1	3.30	3.50	θ_3	5° (TYP)	

θ
 θ

