



گروه فنی مهندسی جوش و برش مقدم

اعتماد از شما کیفیت و تخصص از ما



09153223758



051-37581400



<https://www.moghadamwelding>



<http://instagram.com/moghadam>



<https://t.me/moghadamwelding>



<https://whatsapp.com/channel>



<https://rubika.ir/moghadamwelding>



مشهد خیام شمالی 63 خیابان پردیس 3

برای کسب اطلاعات بیشتر بر روی لینک ها کلیک کنید

- 7 سال سابقه آموزش تعمیرات تخصصی دستگاه های جوش اینورتری تک فاز و 3 فاز
- 7 سال سابقه فروش قطعات الکترونیکی دستگاه جوش تک فاز و 3 فاز
- آموزش تخصصی تحلیل دستگاه های جوش اینورتری مختص ابراز فروشان
- آموزش تخصصی ابراز آلات شارژی

Positive voltage regulator ICs

Datasheet – production data

Features

- Output current up to 1.5 A
- Output voltages of 5; 6; 8; 8.5; 9; 12; 15; 18; 24 V
- Thermal overload protection
- Short circuit protection
- Output transition SOA protection
- 2 % output voltage tolerance (A version)
- Guaranteed in extended temperature range(A version)

Description

The L78xx series of three-terminal positive regulators is available in TO-220, TO-220FP, TO-3, D²PAK and DPAK packages and several fixed output voltages, making it useful in a wide range of applications.

These regulators can provide local on-card regulation, eliminating the distribution problems associated with single point regulation. Each type employs internal current limiting, thermal shut-down and safe area protection, making it essentially indestructible. If adequate heat sinking is provided, they can deliver over 1 A output current. Although designed primarily as fixed voltage regulators, these devices can be used with external components to obtain adjustable voltage and currents.

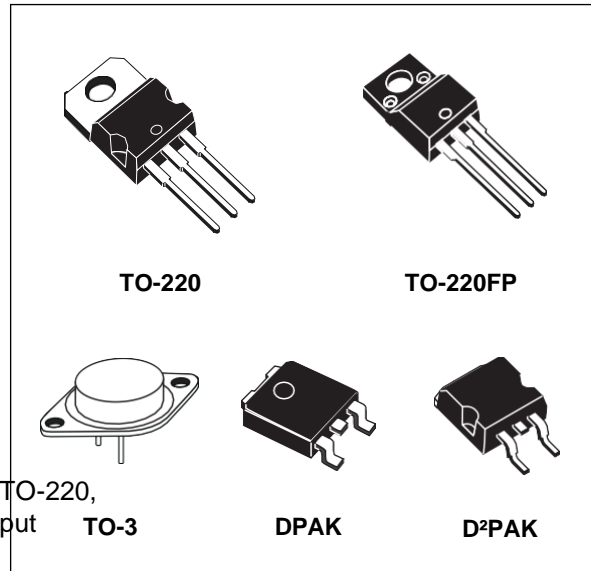

Table 1. Device summary

Part numbers			
L7805	L7806AC	L7809AB	L7815AB
L7805C	L7808C	L7809AC	L7815AC
L7805AB	L7808AB	L7812C	L7818C
L7805AC	L7808AC	L7812AB	L7824C
L7806C	L7885C	L7812AC	L7824AB
L7806AB	L7809C	L7815C	L7824AC

Contents

1	Diagram	5
2	Pin configuration	6
3	Maximum ratings	7
4	Test circuits.....	8
5	Electrical characteristics.....	9
6	Application information.....	28
	6.1 Design consideration.....	28
7	Typical performance.....	37
8	Package mechanical data	39
9	Order codes.....	54
10	Revision history	56

List of tables

Table 1.	Device summary	1
Table 2.	Absolute maximum ratings	7
Table 3.	Thermal data	7
Table 4.	Electrical characteristics of L7805	9
Table 5.	Electrical characteristics of L7805A	10
Table 6.	Electrical characteristics of L7806A	11
Table 7.	Electrical characteristics of L7808A	12
Table 8.	Electrical characteristics of L7809A	13
Table 9.	Electrical characteristics of L7812A	14
Table 10.	Electrical characteristics of L7815A	15
Table 11.	Electrical characteristics of L7824A	16
Table 12.	Electrical characteristics of L7805C	17
Table 13.	Electrical characteristics of L7806C	18
Table 14.	Electrical characteristics of L7808C	19
Table 15.	Electrical characteristics of L7885C	20
Table 16.	Electrical characteristics of L7809C	21
Table 17.	Electrical characteristics of L7810C	22
Table 18.	Electrical characteristics of L7812C	23
Table 19.	Electrical characteristics of L7815C	24
Table 20.	Electrical characteristics of L7818C	25
Table 21.	Electrical characteristics of L7820C	26
Table 22.	Electrical characteristics of L7824C	27
Table 23.	TO-220 mechanical data	39
Table 24.	TO-220FP mechanical data	44
Table 25.	TO-3 mechanical data	45
Table 26.	DPAK mechanical data	47
Table 27.	Tape and reel DPAK mechanical data	48
Table 28.	D ² PAK mechanical data	51
Table 29.	D ² PAK footprint data.....	52
Table 30.	Tape and reel D ² PAK mechanical data	53
Table 31.	Order codes.....	54
Table 32.	Document revision history	56

List of figures

Figure 1.	Block diagram	5
Figure 2.	Pin connections (top view)	6
Figure 3.	Schematic diagram	6
Figure 4.	Application circuits	7
Figure 5.	DC parameter	8
Figure 6.	Load regulation	8
Figure 7.	Ripple rejection	8
Figure 8.	Fixed output regulator	28
Figure 9.	Current regulator	29
Figure 10.	Circuit for increasing output voltage	29
Figure 11.	Adjustable output regulator (7 to 30 V)	29
Figure 12.	0.5 to 10 V regulator	30
Figure 13.	High current voltage regulator	30
Figure 14.	High output current with short circuit protection	30
Figure 15.	Tracking voltage regulator	31
Figure 16.	Split power supply ($\pm 15\text{ V} - 1\text{ A}$)	31
Figure 17.	Negative output voltage circuit	32
Figure 18.	Switching regulator	32
Figure 19.	High input voltage circuit (configuration 1)	32
Figure 20.	High input voltage circuit (configuration 2)	33
Figure 21.	High output voltage regulator	33
Figure 22.	High input and output voltage	33
Figure 23.	Reducing power dissipation with dropping resistor	34
Figure 24.	Remote shutdown	34
Figure 25.	Power AM modulator (unity voltage gain, $I_O \leq 0.5$)	34
Figure 26.	Adjustable output voltage with temperature compensation	35
Figure 27.	Light controllers ($V_{O(\min)} = V_{XX} + V_{BE}$)	35
Figure 28.	Protection against input short-circuit with high capacitance loads	36
Figure 29.	Dropout voltage vs. junction temperature	37
Figure 30.	Peak output current vs. input/output differential voltage	37
Figure 31.	Supply voltage rejection vs. frequency	37
Figure 32.	Output voltage vs. junction temperature	37
Figure 33.	Output impedance vs. frequency	37
Figure 34.	Quiescent current vs. junction temp	37
Figure 35.	Load transient response	38
Figure 36.	Line transient response	38
Figure 37.	Quiescent current vs. input voltage	38
Figure 38.	Drawing dimension TO-220 (type STD-ST Dual Gauge)	40
Figure 39.	Drawing dimension TO-220 (type STD-ST Single Gauge)	41
Figure 40.	Drawing dimension tube for TO-220 Dual Gauge (mm.)	42
Figure 41.	Drawing dimension tube for TO-220 Single Gauge (mm.)	42
Figure 42.	Drawing dimension TO-220FP	43
Figure 43.	Drawing dimension TO-3	45
Figure 44.	Drawing dimension DPAK	46
Figure 45.	Drawing dimension tape and reel for DPAK	48
Figure 46.	Drawing dimension D ² PAK (type STD-ST)	49
Figure 47.	Drawing dimension D ² PAK (type WOOSEOK-Subcon.)	50
Figure 48.	D ² PAK footprint recommended data	52
Figure 49.	Drawing dimension tape and reel for D ² PAK	53

1 Diagram

Figure 1. Block diagram

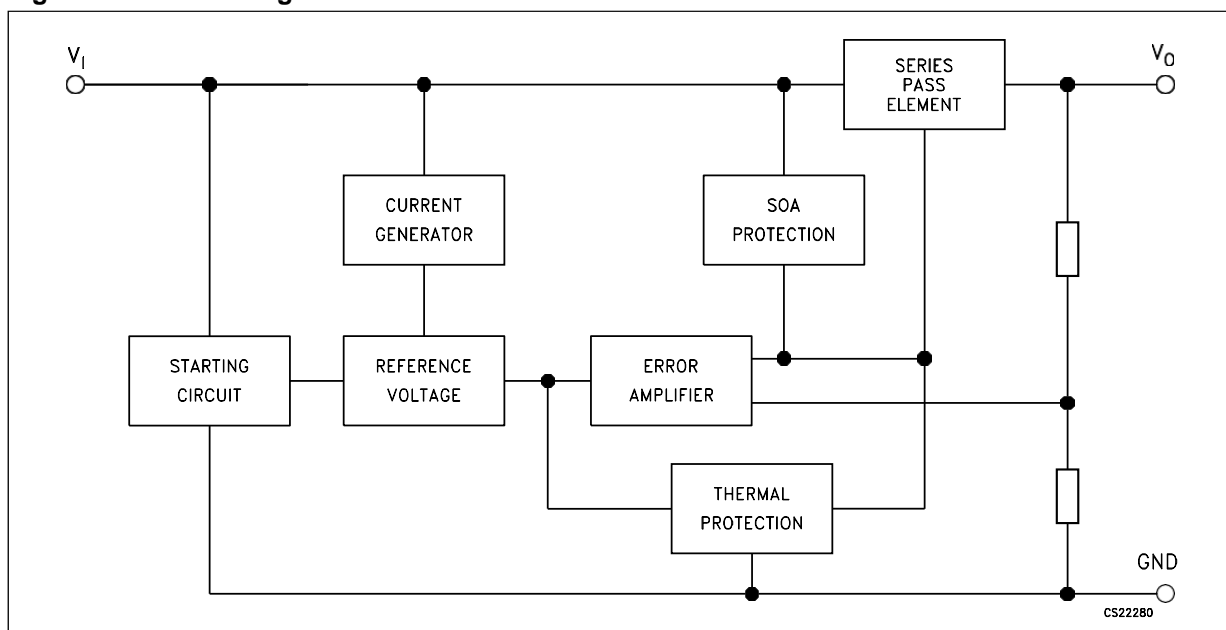

2 Pin configuration

Figure 2. Pin connections (top view)

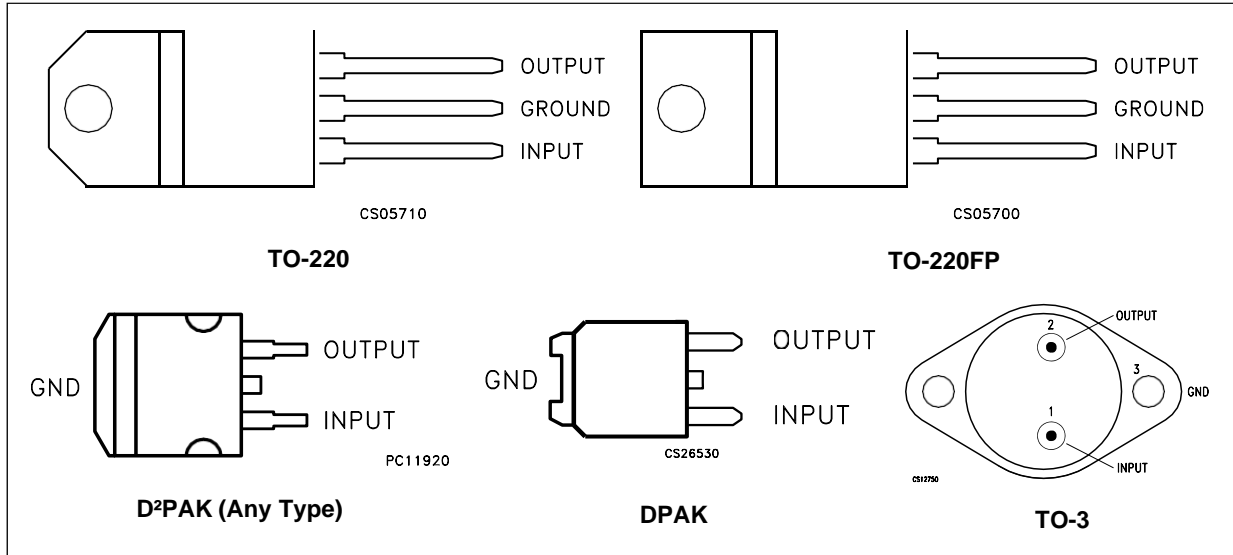
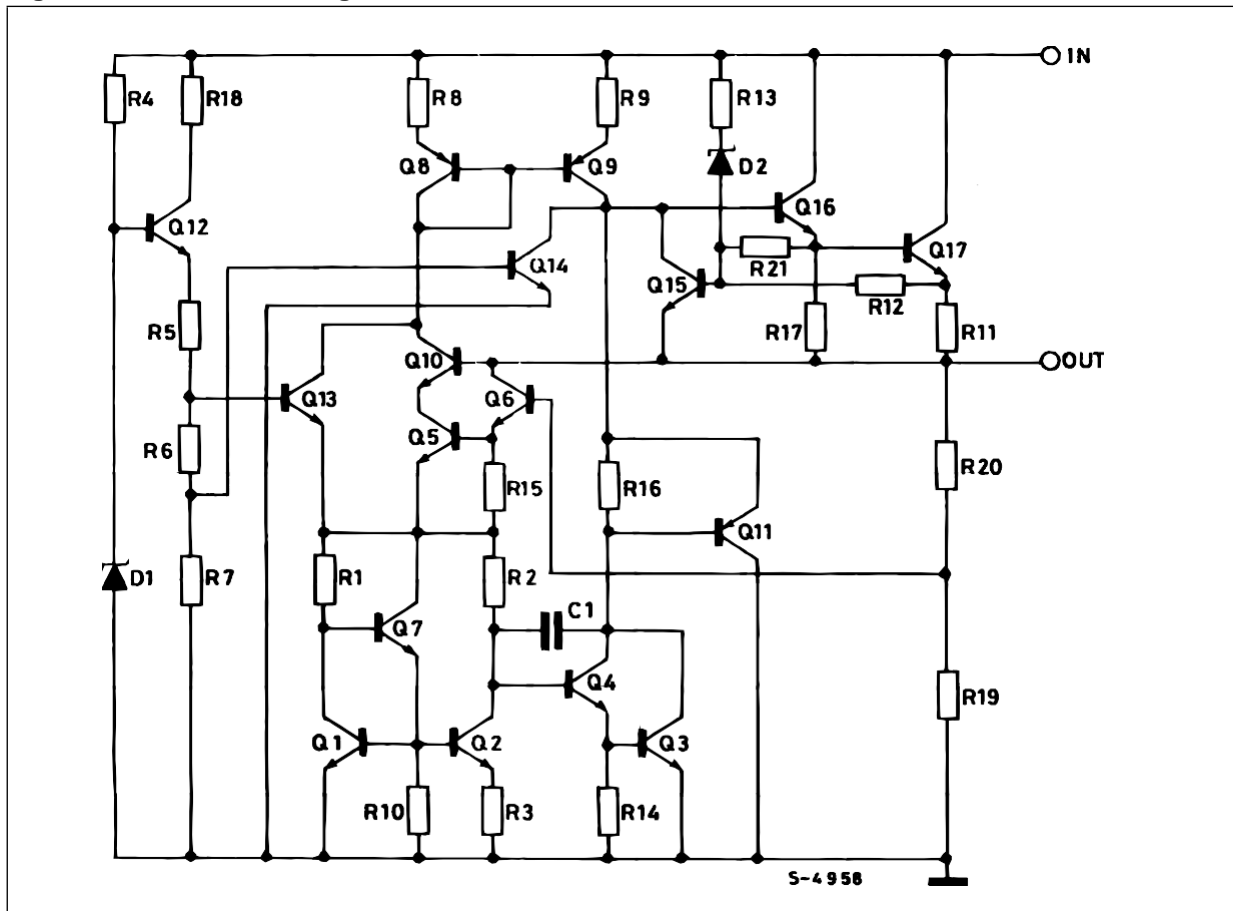

Figure 3. Schematic diagram



3 Maximum ratings

Table 2. Absolute maximum ratings

Symbol	Parameter	Value	Unit
V_I	DC input voltage	for $V_O = 5$ to 18 V	35
		for $V_O = 20, 24$ V	40
I_O	Output current	Internally limited	
P_D	Power dissipation	Internally limited	
T_{STG}	Storage temperature range	-65 to 150	°C
T_{OP}	Operating junction temperature range	for L78xx	-55 to 150
		for L78xxC, L78xxAC	0 to 125
		for L78xxAB	-40 to 125

Note: Absolute maximum ratings are those values beyond which damage to the device may occur. Functional operation under these condition is not implied.

Table 3. Thermal data

Symbol	Parameter	D ² PAK	DPAK	TO-220	TO-220FP	TO-3	Unit
R_{thJC}	Thermal resistance junction-case	3	8	5	5	4	°C/W
R_{thJA}	Thermal resistance junction-ambient	62.5	100	50	60	35	°C/W

Figure 4. Application circuits

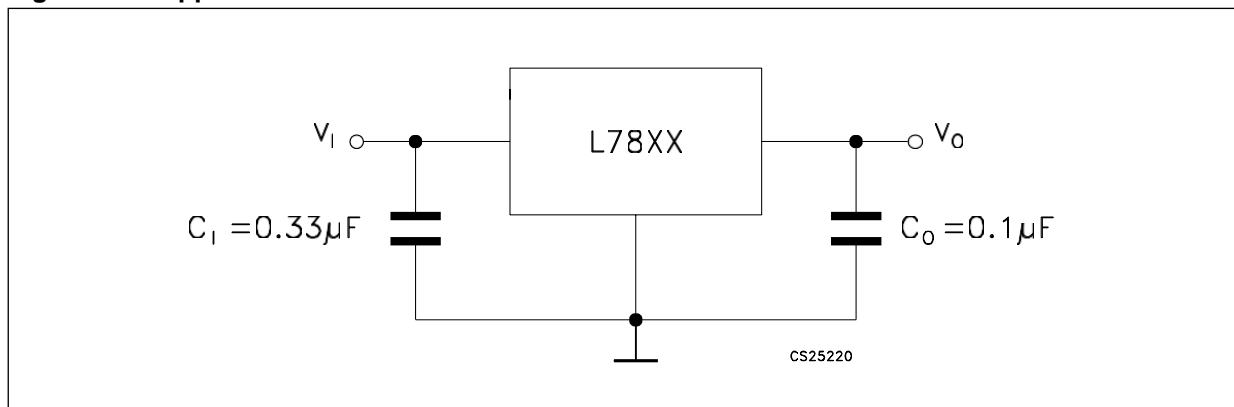

4 Test circuits

Figure 5. DC parameter

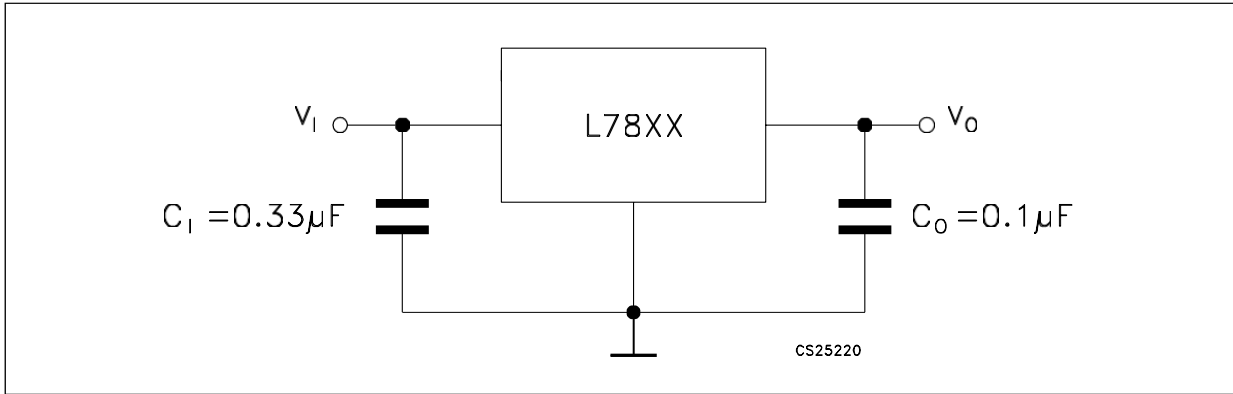

Figure 6. Load regulation

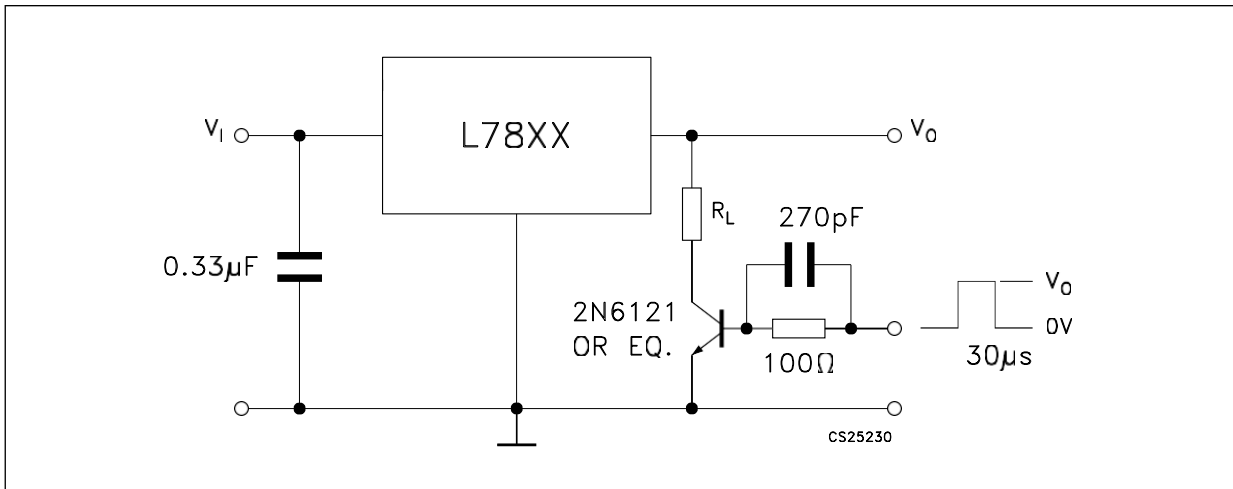
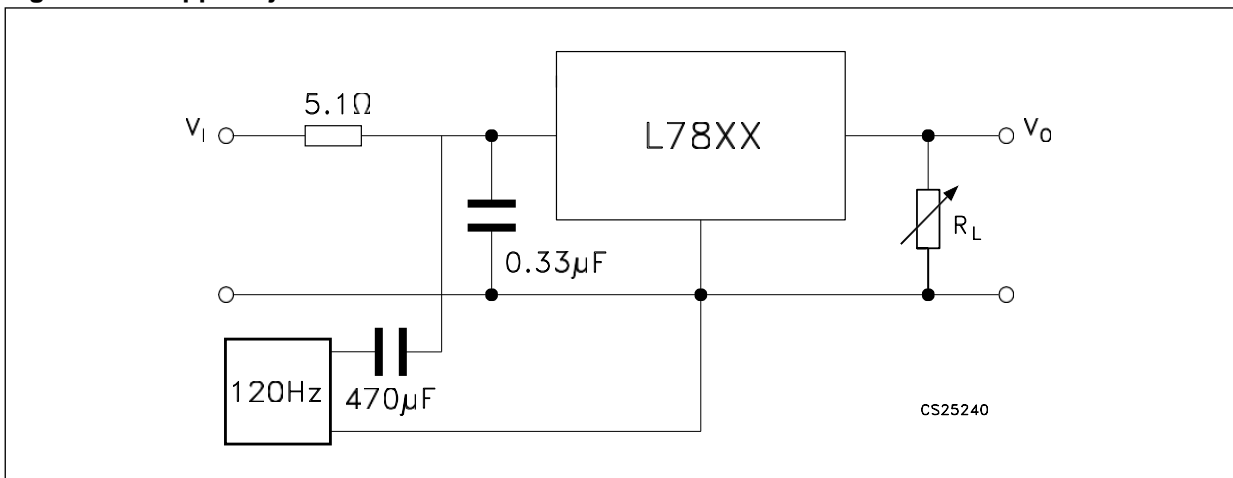

Figure 7. Ripple rejection



5 Electrical characteristics

Refer to the test circuits, $T_J = -55$ to 150 °C, $V_I = 10$ V, $I_O = 500$ mA, $C_I = 0.33$ μ F, $C_O = 0.1$ μ F unless otherwise specified.

Table 4. Electrical characteristics of L7805

Symbol	Parameter	Test conditions	Min.	Typ.	Max.	Unit
V_O	Output voltage	$T_J = 25^\circ\text{C}$	4.8	5	5.2	V
V_O	Output voltage	$I_O = 5$ mA to 1 A, $V_I = 8$ to 20 V	4.65	5	5.35	V
$\Delta V_O^{(1)}$	Line regulation	$V_I = 7$ to 25 V, $T_J = 25^\circ\text{C}$		3	50	mV
		$V_I = 8$ to 12 V, $T_J = 25^\circ\text{C}$		1	25	
$\Delta V_O^{(1)}$	Load regulation	$I_O = 5$ mA to 1.5 A, $T_J = 25^\circ\text{C}$			100	mV
		$I_O = 250$ to 750 mA, $T_J = 25^\circ\text{C}$			25	
I_d	Quiescent current	$T_J = 25^\circ\text{C}$			6	mA
ΔI_d	Quiescent current change	$I_O = 5$ mA to 1 A			0.5	mA
		$V_I = 8$ to 25 V			0.8	
$\Delta V_O/\Delta T$	Output voltage drift	$I_O = 5$ mA		0.6		mV/°C
eN	Output noise voltage	B = 10 Hz to 100 kHz, $T_J = 25^\circ\text{C}$			40	$\mu\text{V}/V_O$
SVR	Supply voltage rejection	$V_I = 8$ to 18 V, $f = 120$ Hz	68			dB
V_d	Dropout voltage	$I_O = 1$ A, $T_J = 25^\circ\text{C}$		2	2.5	V
R_O	Output resistance	$f = 1$ kHz		17		m Ω
I_{sc}	Short circuit current	$V_I = 35$ V, $T_J = 25^\circ\text{C}$		0.75	1.2	A
I_{scp}	Short circuit peak current	$T_J = 25^\circ\text{C}$	1.3	2.2	3.3	A

1. Load and line regulation are specified at constant junction temperature. Changes in V_O due to heating effects must be taken into account separately. Pulse testing with low duty cycle is used.

$V_I = 10\text{ V}$, $I_O = 1\text{ A}$, $T_J = 0\text{ to }125\text{ °C}$ (L7805AC), $T_J = -40\text{ to }125\text{ °C}$ (L7805AB), unless otherwise specified.

Table 5. Electrical characteristics of L7805A

Symbol	Parameter	Test conditions	Min.	Typ.	Max.	Unit
V_O	Output voltage	$T_J = 25\text{ °C}$	4.9	5	5.1	V
V_O	Output voltage	$I_O = 5\text{ mA to }1\text{ A}$, $V_I = 7.5\text{ to }18\text{ V}$	4.8	5	5.2	V
V_O	Output voltage	$I_O = 1\text{ A}$, $V_I = 18\text{ to }20\text{ V}$, $T_J = 25\text{ °C}$	4.8	5	5.2	V
$\Delta V_O^{(1)}$	Line regulation	$V_I = 7.5\text{ to }25\text{ V}$, $I_O = 500\text{ mA}$, $T_J = 25\text{ °C}$		7	50	mV
		$V_I = 8\text{ to }12\text{ V}$		10	50	mV
		$V_I = 8\text{ to }12\text{ V}$, $T_J = 25\text{ °C}$		2	25	mV
		$V_I = 7.3\text{ to }20\text{ V}$, $T_J = 25\text{ °C}$		7	50	mV
$\Delta V_O^{(1)}$	Load regulation	$I_O = 5\text{ mA to }1\text{ A}$		25	100	mV
		$I_O = 5\text{ mA to }1.5\text{ A}$, $T_J = 25\text{ °C}$		30	100	V
		$I_O = 250\text{ to }750\text{ mA}$		8	50	V
I_q	Quiescent current	$T_J = 25\text{ °C}$		4.3	6	mA
					6	mA
ΔI_q	Quiescent current change	$V_I = 8\text{ to }23\text{ V}$, $I_O = 500\text{ mA}$			0.8	mA
		$V_I = 7.5\text{ to }20\text{ V}$, $T_J = 25\text{ °C}$			0.8	mA
		$I_O = 5\text{ mA to }1\text{ A}$			0.5	mA
SVR	Supply voltage rejection	$V_I = 8\text{ to }18\text{ V}$, $f = 120\text{ Hz}$, $I_O = 500\text{ mA}$		68		dB
V_d	Dropout voltage	$I_O = 1\text{ A}$, $T_J = 25\text{ °C}$		2		V
eN	Output noise voltage	$T_A = 25\text{ °C}$, $B = 10\text{ Hz to }100\text{ kHz}$		10		$\mu\text{V}/V_O$
R_O	Output resistance	$f = 1\text{ kHz}$		17		m Ω
I_{sc}	Short circuit current	$V_I = 35\text{ V}$, $T_A = 25\text{ °C}$		0.2		A
I_{scp}	Short circuit peak current	$T_J = 25\text{ °C}$		2.2		A
$\Delta V_O/\Delta T$	Output voltage drift			-1.1		mV/°C

1. Load and line regulation are specified at constant junction temperature. Changes in V_O due to heating effects must be taken into account separately. Pulse testing with low duty cycle is used.

$V_I = 11\text{ V}$, $I_O = 1\text{ A}$, $T_J = 0\text{ to }125\text{ °C}$ (L7806AC), $T_J = -40\text{ to }125\text{ °C}$ (L7806AB), unless otherwise specified.

Table 6. Electrical characteristics of L7806A

Symbol	Parameter	Test conditions	Min.	Typ.	Max.	Unit
V_O	Output voltage	$T_J = 25\text{ °C}$	5.88	6	6.12	V
V_O	Output voltage	$I_O = 5\text{ mA to }1\text{ A}$, $V_I = 8.6\text{ to }19\text{ V}$	5.76	6	6.24	V
V_O	Output voltage	$I_O = 1\text{ A}$, $V_I = 19\text{ to }21\text{ V}$, $T_J = 25\text{ °C}$	5.76	6	6.24	V
$\Delta V_O^{(1)}$	Line regulation	$V_I = 8.6\text{ to }25\text{ V}$, $I_O = 500\text{ mA}$, $T_J = 25\text{ °C}$		9	60	mV
		$V_I = 9\text{ to }13\text{ V}$		11	60	mV
		$V_I = 9\text{ to }13\text{ V}$, $T_J = 25\text{ °C}$		3	30	mV
		$V_I = 8.3\text{ to }21\text{ V}$, $T_J = 25\text{ °C}$		9	60	mV
$\Delta V_O^{(1)}$	Load regulation	$I_O = 5\text{ mA to }1\text{ A}$		25	100	mV
		$I_O = 5\text{ mA to }1.5\text{ A}$, $T_J = 25\text{ °C}$		30	100	V
		$I_O = 250\text{ to }750\text{ mA}$		10	50	V
I_q	Quiescent current	$T_J = 25\text{ °C}$		4.3	6	mA
					6	mA
ΔI_q	Quiescent current change	$V_I = 9\text{ to }24\text{ V}$, $I_O = 500\text{ mA}$			0.8	mA
		$V_I = 8.6\text{ to }21\text{ V}$, $T_J = 25\text{ °C}$			0.8	mA
		$I_O = 5\text{ mA to }1\text{ A}$			0.5	mA
SVR	Supply voltage rejection	$V_I = 9\text{ to }19\text{ V}$, $f = 120\text{ Hz}$, $I_O = 500\text{ mA}$		65		dB
V_d	Dropout voltage	$I_O = 1\text{ A}$, $T_J = 25\text{ °C}$		2		V
eN	Output noise voltage	$T_A = 25\text{ °C}$, $B = 10\text{ Hz to }100\text{ kHz}$		10		$\mu\text{V}/V_O$
R_O	Output resistance	$f = 1\text{ kHz}$		17		m Ω
I_{sc}	Short circuit current	$V_I = 35\text{ V}$, $T_A = 25\text{ °C}$		0.2		A
I_{scp}	Short circuit peak current	$T_J = 25\text{ °C}$		2.2		A
$\Delta V_O/\Delta T$	Output voltage drift			-0.8		mV/°C

1. Load and line regulation are specified at constant junction temperature. Changes in V_O due to heating effects must be taken into account separately. Pulse testing with low duty cycle is used.

$V_I = 14\text{ V}$, $I_O = 1\text{ A}$, $T_J = 0\text{ to }125\text{ °C}$ (L7808AC), $T_J = -40\text{ to }125\text{ °C}$ (L7808AB), unless otherwise specified.

Table 7. Electrical characteristics of L7808A

Symbol	Parameter	Test conditions	Min.	Typ.	Max.	Unit
V_O	Output voltage	$T_J = 25\text{ °C}$	7.84	8	8.16	V
V_O	Output voltage	$I_O = 5\text{ mA to }1\text{ A}$, $V_I = 10.6\text{ to }21\text{ V}$	7.7	8	8.3	V
V_O	Output voltage	$I_O = 1\text{ A}$, $V_I = 21\text{ to }23\text{ V}$, $T_J = 25\text{ °C}$	7.7	8	8.3	V
$\Delta V_O^{(1)}$	Line regulation	$V_I = 10.6\text{ to }25\text{ V}$, $I_O = 500\text{ mA}$, $T_J = 25\text{ °C}$		12	80	mV
		$V_I = 11\text{ to }17\text{ V}$		15	80	mV
		$V_I = 11\text{ to }17\text{ V}$, $T_J = 25\text{ °C}$		5	40	mV
		$V_I = 10.4\text{ to }23\text{ V}$, $T_J = 25\text{ °C}$		12	80	mV
$\Delta V_O^{(1)}$	Load regulation	$I_O = 5\text{ mA to }1\text{ A}$		25	100	mV
		$I_O = 5\text{ mA to }1.5\text{ A}$, $T_J = 25\text{ °C}$		30	100	V
		$I_O = 250\text{ to }750\text{ mA}$		10	50	V
I_q	Quiescent current	$T_J = 25\text{ °C}$		4.3	6	mA
					6	mA
ΔI_q	Quiescent current change	$V_I = 11\text{ to }23\text{ V}$, $I_O = 500\text{ mA}$			0.8	mA
		$V_I = 10.6\text{ to }23\text{ V}$, $T_J = 25\text{ °C}$			0.8	mA
		$I_O = 5\text{ mA to }1\text{ A}$			0.5	mA
SVR	Supply voltage rejection	$V_I = 11.5\text{ to }21.5\text{ V}$, $f = 120\text{ Hz}$, $I_O = 500\text{ mA}$		62		dB
V_d	Dropout voltage	$I_O = 1\text{ A}$, $T_J = 25\text{ °C}$		2		V
eN	Output noise voltage	$T_A = 25\text{ °C}$, $B = 10\text{ Hz to }100\text{ kHz}$		10		$\mu\text{V}/V_O$
R_O	Output resistance	$f = 1\text{ kHz}$		18		m Ω
I_{sc}	Short circuit current	$V_I = 35\text{ V}$, $T_A = 25\text{ °C}$		0.2		A
I_{scp}	Short circuit peak current	$T_J = 25\text{ °C}$		2.2		A
$\Delta V_O/\Delta T$	Output voltage drift			-0.8		mV/°C

1. Load and line regulation are specified at constant junction temperature. Changes in V_O due to heating effects must be taken into account separately. Pulse testing with low duty cycle is used.

$V_I = 15\text{ V}$, $I_O = 1\text{ A}$, $T_J = 0\text{ to }125\text{ °C}$ (L7809AC), $T_J = -40\text{ to }125\text{ °C}$ (L7809AB), unless otherwise specified.

Table 8. Electrical characteristics of L7809A

Symbol	Parameter	Test conditions	Min.	Typ.	Max.	Unit
V_O	Output voltage	$T_J = 25\text{ °C}$	8.82	9	9.18	V
V_O	Output voltage	$I_O = 5\text{ mA to }1\text{ A}$, $V_I = 10.6\text{ to }22\text{ V}$	8.65	9	9.35	V
V_O	Output voltage	$I_O = 1\text{ A}$, $V_I = 22\text{ to }24\text{ V}$, $T_J = 25\text{ °C}$	8.65	9	9.35	V
$\Delta V_O^{(1)}$	Line regulation	$V_I = 10.6\text{ to }25\text{ V}$, $I_O = 500\text{ mA}$, $T_J = 25\text{ °C}$		12	90	mV
		$V_I = 11\text{ to }17\text{ V}$		15	90	mV
		$V_I = 11\text{ to }17\text{ V}$, $T_J = 25\text{ °C}$		5	45	mV
		$V_I = 11.4\text{ to }23\text{ V}$, $T_J = 25\text{ °C}$		12	90	mV
$\Delta V_O^{(1)}$	Load regulation	$I_O = 5\text{ mA to }1\text{ A}$		25	100	mV
		$I_O = 5\text{ mA to }1.5\text{ A}$, $T_J = 25\text{ °C}$		30	100	V
		$I_O = 250\text{ to }750\text{ mA}$		10	50	V
I_q	Quiescent current	$T_J = 25\text{ °C}$		4.3	6	mA
					6	mA
ΔI_q	Quiescent current change	$V_I = 11\text{ to }25\text{ V}$, $I_O = 500\text{ mA}$			0.8	mA
		$V_I = 10.6\text{ to }23\text{ V}$, $T_J = 25\text{ °C}$			0.8	mA
		$I_O = 5\text{ mA to }1\text{ A}$			0.5	mA
SVR	Supply voltage rejection	$V_I = 11.5\text{ to }21.5\text{ V}$, $f = 120\text{ Hz}$, $I_O = 500\text{ mA}$		61		dB
V_d	Dropout voltage	$I_O = 1\text{ A}$, $T_J = 25\text{ °C}$		2		V
eN	Output noise voltage	$T_A = 25\text{ °C}$, $B = 10\text{ Hz to }100\text{ kHz}$		10		$\mu\text{V}/V_O$
R_O	Output resistance	$f = 1\text{ kHz}$		18		m Ω
I_{sc}	Short circuit current	$V_I = 35\text{ V}$, $T_A = 25\text{ °C}$		0.2		A
I_{scp}	Short circuit peak current	$T_J = 25\text{ °C}$		2.2		A
$\Delta V_O/\Delta T$	Output voltage drift			-0.8		mV/°C

1. Load and line regulation are specified at constant junction temperature. Changes in V_O due to heating effects must be taken into account separately. Pulse testing with low duty cycle is used.

$V_I = 19\text{ V}$, $I_O = 1\text{ A}$, $T_J = 0\text{ to }125\text{ °C}$ (L7812AC), $T_J = -40\text{ to }125\text{ °C}$ (L7812AB), unless otherwise specified.

Table 9. Electrical characteristics of L7812A

Symbol	Parameter	Test conditions	Min.	Typ.	Max.	Unit
V_O	Output voltage	$T_J = 25\text{ °C}$	11.75	12	12.25	V
V_O	Output voltage	$I_O = 5\text{ mA to }1\text{ A}$, $V_I = 14.8\text{ to }25\text{ V}$	11.5	12	12.5	V
V_O	Output voltage	$I_O = 1\text{ A}$, $V_I = 25\text{ to }27\text{ V}$, $T_J = 25\text{ °C}$	11.5	12	12.5	V
$\Delta V_O^{(1)}$	Line regulation	$V_I = 14.8\text{ to }30\text{ V}$, $I_O = 500\text{ mA}$, $T_J = 25\text{ °C}$		13	120	mV
		$V_I = 16\text{ to }12\text{ V}$		16	120	mV
		$V_I = 16\text{ to }12\text{ V}$, $T_J = 25\text{ °C}$		6	60	mV
		$V_I = 14.5\text{ to }27\text{ V}$, $T_J = 25\text{ °C}$		13	120	mV
$\Delta V_O^{(1)}$	Load regulation	$I_O = 5\text{ mA to }1\text{ A}$		25	100	mV
		$I_O = 5\text{ mA to }1.5\text{ A}$, $T_J = 25\text{ °C}$		30	100	V
		$I_O = 250\text{ to }750\text{ mA}$		10	50	V
I_q	Quiescent current	$T_J = 25\text{ °C}$		4.4	6	mA
					6	mA
ΔI_q	Quiescent current change	$V_I = 15\text{ to }30\text{ V}$, $I_O = 500\text{ mA}$			0.8	mA
		$V_I = 14.8\text{ to }27\text{ V}$, $T_J = 25\text{ °C}$			0.8	mA
		$I_O = 5\text{ mA to }1\text{ A}$			0.5	mA
SVR	Supply voltage rejection	$V_I = 15\text{ to }25\text{ V}$, $f = 120\text{ Hz}$, $I_O = 500\text{ mA}$		60		dB
V_d	Dropout voltage	$I_O = 1\text{ A}$, $T_J = 25\text{ °C}$		2		V
eN	Output noise voltage	$T_A = 25\text{ °C}$, $B = 10\text{ Hz to }100\text{ kHz}$		10		$\mu\text{V}/V_O$
R_O	Output resistance	$f = 1\text{ kHz}$		18		$\text{m}\Omega$
I_{sc}	Short circuit current	$V_I = 35\text{ V}$, $T_A = 25\text{ °C}$		0.2		A
I_{scp}	Short circuit peak current	$T_J = 25\text{ °C}$		2.2		A
$\Delta V_O/\Delta T$	Output voltage drift			-1		$\text{mV}/\text{°C}$

1. Load and line regulation are specified at constant junction temperature. Changes in V_O due to heating effects must be taken into account separately. Pulse testing with low duty cycle is used.

$V_I = 23\text{ V}$, $I_O = 1\text{ A}$, $T_J = 0\text{ to }125\text{ °C}$ (L7815AC), $T_J = -40\text{ to }125\text{ °C}$ (L7815AB), unless otherwise specified.

Table 10. Electrical characteristics of L7815A

Symbol	Parameter	Test conditions	Min.	Typ.	Max.	Unit
V_O	Output voltage	$T_J = 25\text{ °C}$	14.7	15	15.3	V
V_O	Output voltage	$I_O = 5\text{ mA to }1\text{ A}$, $V_I = 17.9\text{ to }28\text{ V}$	14.4	15	15.6	V
V_O	Output voltage	$I_O = 1\text{ A}$, $V_I = 28\text{ to }30\text{ V}$, $T_J = 25\text{ °C}$	14.4	15	15.6	V
$\Delta V_O^{(1)}$	Line regulation	$V_I = 17.9\text{ to }30\text{ V}$, $I_O = 500\text{ mA}$, $T_J = 25\text{ °C}$		13	150	mV
		$V_I = 20\text{ to }26\text{ V}$		16	150	mV
		$V_I = 20\text{ to }26\text{ V}$, $T_J = 25\text{ °C}$		6	75	mV
		$V_I = 17.5\text{ to }30\text{ V}$, $T_J = 25\text{ °C}$		13	150	mV
$\Delta V_O^{(1)}$	Load regulation	$I_O = 5\text{ mA to }1\text{ A}$		25	100	mV
		$I_O = 5\text{ mA to }1.5\text{ A}$, $T_J = 25\text{ °C}$		30	100	V
		$I_O = 250\text{ to }750\text{ mA}$		10	50	V
I_q	Quiescent current	$T_J = 25\text{ °C}$		4.4	6	mA
					6	mA
ΔI_q	Quiescent current change	$V_I = 17.5\text{ to }30\text{ V}$, $I_O = 500\text{ mA}$			0.8	mA
		$V_I = 17.5\text{ to }30\text{ V}$, $T_J = 25\text{ °C}$			0.8	mA
		$I_O = 5\text{ mA to }1\text{ A}$			0.5	mA
SVR	Supply voltage rejection	$V_I = 18.5\text{ to }28.5\text{ V}$, $f = 120\text{ Hz}$, $I_O = 500\text{ mA}$		58		dB
V_d	Dropout voltage	$I_O = 1\text{ A}$, $T_J = 25\text{ °C}$		2		V
eN	Output noise voltage	$T_A = 25\text{ °C}$, $B = 10\text{ Hz to }100\text{ kHz}$		10		$\mu\text{V}/V_O$
R_O	Output resistance	$f = 1\text{ kHz}$		19		m Ω
I_{sc}	Short circuit current	$V_I = 35\text{ V}$, $T_A = 25\text{ °C}$		0.2		A
I_{scp}	Short circuit peak current	$T_J = 25\text{ °C}$		2.2		A
$\Delta V_O/\Delta T$	Output voltage drift			-1		mV/°C

1. Load and line regulation are specified at constant junction temperature. Changes in V_O due to heating effects must be taken into account separately. Pulse testing with low duty cycle is used.

$V_I = 33\text{ V}$, $I_O = 1\text{ A}$, $T_J = 0\text{ to }125\text{ °C}$ (L7824AC), $T_J = -40\text{ to }125\text{ °C}$ (L7824AB), unless otherwise specified.

Table 11. Electrical characteristics of L7824A

Symbol	Parameter	Test conditions	Min.	Typ.	Max.	Unit
V_O	Output voltage	$T_J = 25\text{ °C}$	23.5	24	24.5	V
V_O	Output voltage	$I_O = 5\text{ mA to }1\text{ A}$, $V_I = 27.3\text{ to }37\text{ V}$	23	24	25	V
V_O	Output voltage	$I_O = 1\text{ A}$, $V_I = 37\text{ to }38\text{ V}$, $T_J = 25\text{ °C}$	23	24	25	V
$\Delta V_O^{(1)}$	Line regulation	$V_I = 27\text{ to }38\text{ V}$, $I_O = 500\text{ mA}$, $T_J = 25\text{ °C}$		31	240	mV
		$V_I = 30\text{ to }36\text{ V}$		35	200	mV
		$V_I = 30\text{ to }36\text{ V}$, $T_J = 25\text{ °C}$		14	120	mV
		$V_I = 26.7\text{ to }38\text{ V}$, $T_J = 25\text{ °C}$		31	240	mV
$\Delta V_O^{(1)}$	Load regulation	$I_O = 5\text{ mA to }1\text{ A}$		25	100	mV
		$I_O = 5\text{ mA to }1.5\text{ A}$, $T_J = 25\text{ °C}$		30	100	V
		$I_O = 250\text{ to }750\text{ mA}$		10	50	V
I_q	Quiescent current	$T_J = 25\text{ °C}$		4.6	6	mA
					6	mA
ΔI_q	Quiescent current change	$V_I = 27.3\text{ to }38\text{ V}$, $I_O = 500\text{ mA}$			0.8	mA
		$V_I = 27.3\text{ to }38\text{ V}$, $T_J = 25\text{ °C}$			0.8	mA
		$I_O = 5\text{ mA to }1\text{ A}$			0.5	mA
SVR	Supply voltage rejection	$V_I = 28\text{ to }38\text{ V}$, $f = 120\text{ Hz}$, $I_O = 500\text{ mA}$		54		dB
V_d	Dropout voltage	$I_O = 1\text{ A}$, $T_J = 25\text{ °C}$		2		V
eN	Output noise voltage	$T_A = 25\text{ °C}$, $B = 10\text{ Hz to }100\text{ kHz}$		10		$\mu\text{V}/V_O$
R_O	Output resistance	$f = 1\text{ kHz}$		20		m Ω
I_{sc}	Short circuit current	$V_I = 35\text{ V}$, $T_A = 25\text{ °C}$		0.2		A
I_{scp}	Short circuit peak current	$T_J = 25\text{ °C}$		2.2		A
$\Delta V_O/\Delta T$	Output voltage drift			-1.5		mV/°C

1. Load and line regulation are specified at constant junction temperature. Changes in V_O due to heating effects must be taken into account separately. Pulse testing with low duty cycle is used.

Refer to the test circuits, $T_J = 0$ to 125 °C, $V_I = 10$ V, $I_O = 500$ mA, $C_I = 0.33$ μ F, $C_O = 0.1$ μ F unless otherwise specified.

Table 12. Electrical characteristics of L7805C

Symbol	Parameter	Test conditions	Min.	Typ.	Max.	Unit
V_O	Output voltage	$T_J = 25^\circ\text{C}$	4.8	5	5.2	V
V_O	Output voltage	$I_O = 5$ mA to 1 A, $V_I = 7$ to 18 V	4.75	5	5.25	V
V_O	Output voltage	$I_O = 1$ A, $V_I = 18$ to 20V, $T_J = 25^\circ\text{C}$	4.75	5	5.25	V
$\Delta V_O^{(1)}$	Line regulation	$V_I = 7$ to 25 V, $T_J = 25^\circ\text{C}$		3	100	mV
		$V_I = 8$ to 12 V, $T_J = 25^\circ\text{C}$		1	50	
$\Delta V_O^{(1)}$	Load regulation	$I_O = 5$ mA to 1.5 A, $T_J = 25^\circ\text{C}$			100	mV
		$I_O = 250$ to 750 mA, $T_J = 25^\circ\text{C}$			50	
I_d	Quiescent current	$T_J = 25^\circ\text{C}$			8	mA
ΔI_d	Quiescent current change	$I_O = 5$ mA to 1 A			0.5	mA
		$V_I = 7$ to 23 V			0.8	
$\Delta V_O/\Delta T$	Output voltage drift	$I_O = 5$ mA		-1.1		mV/°C
eN	Output noise voltage	B = 10 Hz to 100 kHz, $T_J = 25^\circ\text{C}$		40		$\mu\text{V}/V_O$
SVR	Supply voltage rejection	$V_I = 8$ to 18 V, $f = 120$ Hz	62			dB
V_d	Dropout voltage	$I_O = 1$ A, $T_J = 25^\circ\text{C}$		2		V
R_O	Output resistance	$f = 1$ kHz		17		m Λ
I_{sc}	Short circuit current	$V_I = 35$ V, $T_J = 25^\circ\text{C}$		0.75		A
I_{scp}	Short circuit peak current	$T_J = 25^\circ\text{C}$		2.2		A

1. Load and line regulation are specified at constant junction temperature. Changes in V_O due to heating effects must be taken into account separately. Pulse testing with low duty cycle is used.

Refer to the test circuits, $T_J = 0$ to 125 °C, $V_I = 11$ V, $I_O = 500$ mA, $C_I = 0.33$ μ F, $C_O = 0.1$ μ F unless otherwise specified.

Table 13. Electrical characteristics of L7806C

Symbol	Parameter	Test conditions	Min.	Typ.	Max.	Unit
V_O	Output voltage	$T_J = 25^\circ\text{C}$	5.75	6	6.25	V
V_O	Output voltage	$I_O = 5$ mA to 1 A, $V_I = 8$ to 19 V	5.7	6	6.3	V
V_O	Output voltage	$I_O = 1$ A, $V_I = 19$ to 21 V, $T_J = 25^\circ\text{C}$	5.7	6	6.3	V
$\Delta V_O^{(1)}$	Line regulation	$V_I = 8$ to 25 V, $T_J = 25^\circ\text{C}$			120	mV
		$V_I = 9$ to 13 V, $T_J = 25^\circ\text{C}$			60	
$\Delta V_O^{(1)}$	Load regulation	$I_O = 5$ mA to 1.5 A, $T_J = 25^\circ\text{C}$			120	mV
		$I_O = 250$ to 750 mA, $T_J = 25^\circ\text{C}$			60	
I_d	Quiescent current	$T_J = 25^\circ\text{C}$			8	mA
ΔI_d	Quiescent current change	$I_O = 5$ mA to 1 A			0.5	mA
		$V_I = 8$ to 24 V			1.3	
$\Delta V_O/\Delta T$	Output voltage drift	$I_O = 5$ mA		-0.8		mV/°C
eN	Output noise voltage	B = 10 Hz to 100 kHz, $T_J = 25^\circ\text{C}$		45		$\mu\text{V}/V_O$
SVR	Supply voltage rejection	$V_I = 9$ to 19 V, $f = 120$ Hz	59			dB
V_d	Dropout voltage	$I_O = 1$ A, $T_J = 25^\circ\text{C}$		2		V
R_O	Output resistance	$f = 1$ kHz		19		m Λ
I_{sc}	Short circuit current	$V_I = 35$ V, $T_J = 25^\circ\text{C}$		0.55		A
I_{scp}	Short circuit peak current	$T_J = 25^\circ\text{C}$		2.2		A

1. Load and line regulation are specified at constant junction temperature. Changes in V_O due to heating effects must be taken into account separately. Pulse testing with low duty cycle is used.

Refer to the test circuits, $T_J = 0$ to 125 °C, $V_I = 14$ V, $I_O = 500$ mA, $C_I = 0.33$ μ F, $C_O = 0.1$ μ F unless otherwise specified.

Table 14. Electrical characteristics of L7808C

Symbol	Parameter	Test conditions	Min.	Typ.	Max.	Unit
V_O	Output voltage	$T_J = 25^\circ\text{C}$	7.7	8	8.3	V
V_O	Output voltage	$I_O = 5$ mA to 1 A, $V_I = 10.5$ to 21 V	7.6	8	8.4	V
V_O	Output voltage	$I_O = 1$ A, $V_I = 21$ to 25 V, $T_J = 25^\circ\text{C}$	7.6	8	8.4	V
$\Delta V_O^{(1)}$	Line regulation	$V_I = 10.5$ to 25 V, $T_J = 25^\circ\text{C}$			160	mV
		$V_I = 11$ to 17 V, $T_J = 25^\circ\text{C}$			80	
$\Delta V_O^{(1)}$	Load regulation	$I_O = 5$ mA to 1.5 A, $T_J = 25^\circ\text{C}$			160	mV
		$I_O = 250$ to 750 mA, $T_J = 25^\circ\text{C}$			80	
I_d	Quiescent current	$T_J = 25^\circ\text{C}$			8	mA
ΔI_d	Quiescent current change	$I_O = 5$ mA to 1 A			0.5	mA
		$V_I = 10.5$ to 25 V			1	
$\Delta V_O/\Delta T$	Output voltage drift	$I_O = 5$ mA		-0.8		mV/°C
eN	Output noise voltage	B = 10 Hz to 100 kHz, $T_J = 25^\circ\text{C}$		52		$\mu\text{V}/V_O$
SVR	Supply voltage rejection	$V_I = 11.5$ to 21.5 V, $f = 120$ Hz	56			dB
V_d	Dropout voltage	$I_O = 1$ A, $T_J = 25^\circ\text{C}$		2		V
R_O	Output resistance	$f = 1$ kHz		16		m Λ
I_{sc}	Short circuit current	$V_I = 35$ V, $T_J = 25^\circ\text{C}$		0.45		A
I_{scp}	Short circuit peak current	$T_J = 25^\circ\text{C}$		2.2		A

1. Load and line regulation are specified at constant junction temperature. Changes in V_O due to heating effects must be taken into account separately. Pulse testing with low duty cycle is used.

Refer to the test circuits, $T_J = 0$ to 125 °C, $V_I = 14.5$ V, $I_O = 500$ mA, $C_I = 0.33$ μ F, $C_O = 0.1$ μ F unless otherwise specified.

Table 15. Electrical characteristics of L7885C

Symbol	Parameter	Test conditions	Min.	Typ.	Max.	Unit
V_O	Output voltage	$T_J = 25^\circ\text{C}$	8.2	8.5	8.8	V
V_O	Output voltage	$I_O = 5$ mA to 1 A, $V_I = 11$ to 21.5 V	8.1	8.5	8.9	V
V_O	Output voltage	$I_O = 1$ A, $V_I = 21.5$ to 26 V, $T_J = 25^\circ\text{C}$	8.1	8.5	8.9	V
$\Delta V_O^{(1)}$	Line regulation	$V_I = 11$ to 27 V, $T_J = 25^\circ\text{C}$			160	mV
		$V_I = 11.5$ to 17.5 V, $T_J = 25^\circ\text{C}$			80	
$\Delta V_O^{(1)}$	Load regulation	$I_O = 5$ mA to 1.5 A, $T_J = 25^\circ\text{C}$			160	mV
		$I_O = 250$ to 750 mA, $T_J = 25^\circ\text{C}$			80	
I_d	Quiescent current	$T_J = 25^\circ\text{C}$			8	mA
ΔI_d	Quiescent current change	$I_O = 5$ mA to 1 A			0.5	mA
		$V_I = 11$ to 26 V			1	
$\Delta V_O/\Delta T$	Output voltage drift	$I_O = 5$ mA		-0.8		mV/°C
eN	Output noise voltage	B = 10 Hz to 100 kHz, $T_J = 25^\circ\text{C}$		55		$\mu\text{V}/V_O$
SVR	Supply voltage rejection	$V_I = 12$ to 22 V, $f = 120$ Hz	56			dB
V_d	Dropout voltage	$I_O = 1$ A, $T_J = 25^\circ\text{C}$		2		V
R_O	Output resistance	$f = 1$ kHz		16		m Λ
I_{sc}	Short circuit current	$V_I = 35$ V, $T_J = 25^\circ\text{C}$		0.45		A
I_{scp}	Short circuit peak current	$T_J = 25^\circ\text{C}$		2.2		A

1. Load and line regulation are specified at constant junction temperature. Changes in V_O due to heating effects must be taken into account separately. Pulse testing with low duty cycle is used.

Refer to the test circuits, $T_J = 0$ to 125 °C, $V_I = 15$ V, $I_O = 500$ mA, $C_I = 0.33$ μ F, $C_O = 0.1$ μ F unless otherwise specified.

Table 16. Electrical characteristics of L7809C

Symbol	Parameter	Test conditions	Min.	Typ.	Max.	Unit
V_O	Output voltage	$T_J = 25^\circ\text{C}$	8.64	9	9.36	V
V_O	Output voltage	$I_O = 5$ mA to 1 A, $V_I = 11.5$ to 22 V	8.55	9	9.45	V
V_O	Output voltage	$I_O = 1$ A, $V_I = 22$ to 26 V, $T_J = 25^\circ\text{C}$	8.55	9	9.45	V
$\Delta V_O^{(1)}$	Line regulation	$V_I = 11.5$ to 26 V, $T_J = 25^\circ\text{C}$			180	mV
		$V_I = 12$ to 18 V, $T_J = 25^\circ\text{C}$			90	
$\Delta V_O^{(1)}$	Load regulation	$I_O = 5$ mA to 1.5 A, $T_J = 25^\circ\text{C}$			180	mV
		$I_O = 250$ to 750 mA, $T_J = 25^\circ\text{C}$			90	
I_d	Quiescent current	$T_J = 25^\circ\text{C}$			8	mA
ΔI_d	Quiescent current change	$I_O = 5$ mA to 1 A			0.5	mA
		$V_I = 11.5$ to 26 V			1	
$\Delta V_O/\Delta T$	Output voltage drift	$I_O = 5$ mA		-1		mV/°C
eN	Output noise voltage	B = 10 Hz to 100 kHz, $T_J = 25^\circ\text{C}$		70		$\mu\text{V}/V_O$
SVR	Supply voltage rejection	$V_I = 12$ to 23 V, $f = 120$ Hz	55			dB
V_d	Dropout voltage	$I_O = 1$ A, $T_J = 25^\circ\text{C}$		2		V
R_O	Output resistance	$f = 1$ kHz		17		m Λ
I_{sc}	Short circuit current	$V_I = 35$ V, $T_J = 25^\circ\text{C}$		0.40		A
I_{scp}	Short circuit peak current	$T_J = 25^\circ\text{C}$		2.2		A

1. Load and line regulation are specified at constant junction temperature. Changes in V_O due to heating effects must be taken into account separately. Pulse testing with low duty cycle is used.

Refer to the test circuits, $T_J = 0$ to 125 °C, $V_I = 15$ V, $I_O = 500$ mA, $C_I = 0.33$ μ F, $C_O = 0.1$ μ F unless otherwise specified.

Table 17. Electrical characteristics of L7810C

Symbol	Parameter	Test conditions	Min.	Typ.	Max.	Unit
V_O	Output voltage	$T_J = 25^\circ\text{C}$	9.6	10	10.4	V
V_O	Output voltage	$I_O = 5$ mA to 1 A, $V_I = 12.5$ to 23 V	9.5	10	10.5	V
V_O	Output voltage	$I_O = 1$ A, $V_I = 23$ to 26 V, $T_J = 25^\circ\text{C}$	9.5	10	10.5	V
$\Delta V_O^{(1)}$	Line regulation	$V_I = 12.5$ to 26 V, $T_J = 25^\circ\text{C}$			200	mV
		$V_I = 13.5$ to 19 V, $T_J = 25^\circ\text{C}$			100	
$\Delta V_O^{(1)}$	Load regulation	$I_O = 5$ mA to 1.5 A, $T_J = 25^\circ\text{C}$			200	mV
		$I_O = 250$ to 750 mA, $T_J = 25^\circ\text{C}$			100	
I_d	Quiescent current	$T_J = 25^\circ\text{C}$			8	mA
ΔI_d	Quiescent current change	$I_O = 5$ mA to 1 A			0.5	mA
		$V_I = 12.5$ to 26 V			1	
$\Delta V_O/\Delta T$	Output voltage drift	$I_O = 5$ mA		-1		mV/°C
eN	Output noise voltage	B = 10 Hz to 100 kHz, $T_J = 25^\circ\text{C}$		70		$\mu\text{V}/V_O$
SVR	Supply voltage rejection	$V_I = 13$ to 23 V, $f = 120$ Hz	55			dB
V_d	Dropout voltage	$I_O = 1$ A, $T_J = 25^\circ\text{C}$		2		V
R_O	Output resistance	$f = 1$ kHz		17		m Λ
I_{sc}	Short circuit current	$V_I = 35$ V, $T_J = 25^\circ\text{C}$		0.40		A
I_{scp}	Short circuit peak current	$T_J = 25^\circ\text{C}$		2.2		A

1. Load and line regulation are specified at constant junction temperature. Changes in V_O due to heating effects must be taken into account separately. Pulse testing with low duty cycle is used.

Refer to the test circuits, $T_J = 0$ to 125 °C, $V_I = 19$ V, $I_O = 500$ mA, $C_I = 0.33$ μ F, $C_O = 0.1$ μ F unless otherwise specified.

Table 18. Electrical characteristics of L7812C

Symbol	Parameter	Test conditions	Min.	Typ.	Max.	Unit
V_O	Output voltage	$T_J = 25^\circ\text{C}$	11.5	12	12.5	V
V_O	Output voltage	$I_O = 5$ mA to 1 A, $V_I = 14.5$ to 25 V	11.4	12	12.6	V
V_O	Output voltage	$I_O = 1$ A, $V_I = 25$ to 27 V, $T_J = 25^\circ\text{C}$	11.4	12	12.6	V
$\Delta V_O^{(1)}$	Line regulation	$V_I = 14.5$ to 30 V, $T_J = 25^\circ\text{C}$			240	mV
		$V_I = 16$ to 22 V, $T_J = 25^\circ\text{C}$			120	
$\Delta V_O^{(1)}$	Load regulation	$I_O = 5$ mA to 1.5 A, $T_J = 25^\circ\text{C}$			240	mV
		$I_O = 250$ to 750 mA, $T_J = 25^\circ\text{C}$			120	
I_d	Quiescent current	$T_J = 25^\circ\text{C}$			8	mA
ΔI_d	Quiescent current change	$I_O = 5$ mA to 1 A			0.5	mA
		$V_I = 14.5$ to 30 V			1	
$\Delta V_O/\Delta T$	Output voltage drift	$I_O = 5$ mA		-1		mV/°C
eN	Output noise voltage	B = 10 Hz to 100 kHz, $T_J = 25^\circ\text{C}$		75		$\mu\text{V}/V_O$
SVR	Supply voltage rejection	$V_I = 15$ to 25 V, $f = 120$ Hz	55			dB
V_d	Dropout voltage	$I_O = 1$ A, $T_J = 25^\circ\text{C}$		2		V
R_O	Output resistance	$f = 1$ kHz		18		m Λ
I_{sc}	Short circuit current	$V_I = 35$ V, $T_J = 25^\circ\text{C}$		0.35		A
I_{scp}	Short circuit peak current	$T_J = 25^\circ\text{C}$		2.2		A

1. Load and line regulation are specified at constant junction temperature. Changes in V_O due to heating effects must be taken into account separately. Pulse testing with low duty cycle is used.

Refer to the test circuits, $T_J = 0$ to 125 °C, $V_I = 23$ V, $I_O = 500$ mA, $C_I = 0.33$ μ F, $C_O = 0.1$ μ F unless otherwise specified.

Table 19. Electrical characteristics of L7815C

Symbol	Parameter	Test conditions	Min.	Typ.	Max.	Unit
V_O	Output voltage	$T_J = 25^\circ\text{C}$	14.5	15	15.6	V
V_O	Output voltage	$I_O = 5$ mA to 1 A, $V_I = 17.5$ to 28 V	14.25	15	15.75	V
V_O	Output voltage	$I_O = 1$ A, $V_I = 28$ to 30 V, $T_J = 25^\circ\text{C}$	14.25	15	15.75	V
$\Delta V_O^{(1)}$	Line regulation	$V_I = 17.5$ to 30 V, $T_J = 25^\circ\text{C}$			300	mV
		$V_I = 20$ to 26 V, $T_J = 25^\circ\text{C}$			150	
$\Delta V_O^{(1)}$	Load regulation	$I_O = 5$ mA to 1.5 A, $T_J = 25^\circ\text{C}$			300	mV
		$I_O = 250$ to 750 mA, $T_J = 25^\circ\text{C}$			150	
I_d	Quiescent current	$T_J = 25^\circ\text{C}$			8	mA
ΔI_d	Quiescent current change	$I_O = 5$ mA to 1A			0.5	mA
		$V_I = 17.5$ to 30 V			1	
$\Delta V_O/\Delta T$	Output voltage drift	$I_O = 5$ mA		-1		mV/°C
eN	Output noise voltage	$B = 10$ Hz to 100kHz, $T_J = 25^\circ\text{C}$		90		$\mu\text{V}/V_O$
SVR	Supply voltage rejection	$V_I = 18.5$ to 28.5 V, $f = 120$ Hz	54			dB
V_d	Dropout voltage	$I_O = 1$ A, $T_J = 25^\circ\text{C}$		2		V
R_O	Output resistance	$f = 1$ kHz		19		m Λ
I_{sc}	Short circuit current	$V_I = 35$ V, $T_J = 25^\circ\text{C}$		0.23		A
I_{scp}	Short circuit peak current	$T_J = 25^\circ\text{C}$		2.2		A

1. Load and line regulation are specified at constant junction temperature. Changes in V_O due to heating effects must be taken into account separately. Pulse testing with low duty cycle is used.

Refer to the test circuits, $T_J = 0$ to 125 °C, $V_I = 26$ V, $I_O = 500$ mA, $C_I = 0.33$ μ F, $C_O = 0.1$ μ F unless otherwise specified.

Table 20. Electrical characteristics of L7818C

Symbol	Parameter	Test conditions	Min.	Typ.	Max.	Unit
V_O	Output voltage	$T_J = 25^\circ\text{C}$	17.3	18	18.7	V
V_O	Output voltage	$I_O = 5$ mA to 1 A, $V_I = 21$ to 31 V	17.1	18	18.9	V
V_O	Output voltage	$I_O = 1$ A, $V_I = 31$ to 33 V, $T_J = 25^\circ\text{C}$	17.1	18	18.9	V
$\Delta V_O^{(1)}$	Line regulation	$V_I = 21$ to 33 V, $T_J = 25^\circ\text{C}$			360	mV
		$V_I = 24$ to 30 V, $T_J = 25^\circ\text{C}$			180	
$\Delta V_O^{(1)}$	Load regulation	$I_O = 5$ mA to 1.5 A, $T_J = 25^\circ\text{C}$			360	mV
		$I_O = 250$ to 750 mA, $T_J = 25^\circ\text{C}$			180	
I_d	Quiescent current	$T_J = 25^\circ\text{C}$			8	mA
ΔI_d	Quiescent current change	$I_O = 5$ mA to 1 A			0.5	mA
		$V_I = 21$ to 33 V			1	
$\Delta V_O/\Delta T$	Output voltage drift	$I_O = 5$ mA		-1		mV/°C
eN	Output noise voltage	B = 10 Hz to 100 kHz, $T_J = 25^\circ\text{C}$		110		$\mu\text{V}/V_O$
SVR	Supply voltage rejection	$V_I = 22$ to 32 V, $f = 120$ Hz	53			dB
V_d	Dropout voltage	$I_O = 1$ A, $T_J = 25^\circ\text{C}$		2		V
R_O	Output resistance	$f = 1$ kHz		22		m Λ
I_{sc}	Short circuit current	$V_I = 35$ V, $T_J = 25^\circ\text{C}$		0.20		A
I_{scp}	Short circuit peak current	$T_J = 25^\circ\text{C}$		2.1		A

1. Load and line regulation are specified at constant junction temperature. Changes in V_O due to heating effects must be taken into account separately. Pulse testing with low duty cycle is used.

Refer to the test circuits, $T_J = 0$ to 125 °C, $V_I = 28$ V, $I_O = 500$ mA, $C_I = 0.33$ μ F, $C_O = 0.1$ μ F unless otherwise specified.

Table 21. Electrical characteristics of L7820C

Symbol	Parameter	Test conditions	Min.	Typ.	Max.	Unit
V_O	Output voltage	$T_J = 25^\circ\text{C}$	19.2	20	20.8	V
V_O	Output voltage	$I_O = 5$ mA to 1 A, $V_I = 23$ to 33 V	19	20	21	V
V_O	Output voltage	$I_O = 1$ A, $V_I = 33$ to 35 V, $T_J = 25^\circ\text{C}$	19	20	21	V
$\Delta V_O^{(1)}$	Line regulation	$V_I = 22.5$ to 35 V, $T_J = 25^\circ\text{C}$			400	mV
		$V_I = 26$ to 32 V, $T_J = 25^\circ\text{C}$			200	
$\Delta V_O^{(1)}$	Load regulation	$I_O = 5$ mA to 1.5 A, $T_J = 25^\circ\text{C}$			400	mV
		$I_O = 250$ to 750 mA, $T_J = 25^\circ\text{C}$			200	
I_d	Quiescent current	$T_J = 25^\circ\text{C}$			8	mA
ΔI_d	Quiescent current change	$I_O = 5$ mA to 1 A			0.5	mA
		$V_I = 23$ to 35 V			1	
$\Delta V_O/\Delta T$	Output voltage drift	$I_O = 5$ mA		-1		mV/°C
eN	Output noise voltage	B = 10 Hz to 100 kHz, $T_J = 25^\circ\text{C}$		150		$\mu\text{V}/V_O$
SVR	Supply voltage rejection	$V_I = 24$ to 35 V, $f = 120$ Hz	52			dB
V_d	Dropout voltage	$I_O = 1$ A, $T_J = 25^\circ\text{C}$		2		V
R_O	Output resistance	$f = 1$ kHz		24		m Λ
I_{sc}	Short circuit current	$V_I = 35$ V, $T_J = 25^\circ\text{C}$		0.18		A
I_{scp}	Short circuit peak current	$T_J = 25^\circ\text{C}$		2.1		A

1. Load and line regulation are specified at constant junction temperature. Changes in V_O due to heating effects must be taken into account separately. Pulse testing with low duty cycle is used.

Refer to the test circuits, $T_J = 0$ to 125 °C, $V_I = 33$ V, $I_O = 500$ mA, $C_I = 0.33$ μ F, $C_O = 0.1$ μ F unless otherwise specified.

Table 22. Electrical characteristics of L7824C

Symbol	Parameter	Test conditions	Min.	Typ.	Max.	Unit
V_O	Output voltage	$T_J = 25^\circ\text{C}$	23	24	25	V
V_O	Output voltage	$I_O = 5$ mA to 1 A, $V_I = 27$ to 37 V	22.8	24	25.2	V
V_O	Output voltage	$I_O = 1$ A, $V_I = 37$ to 38 V, $T_J = 25^\circ\text{C}$	22.8	24	25.2	V
$\Delta V_O^{(1)}$	Line regulation	$V_I = 27$ to 38 V, $T_J = 25^\circ\text{C}$			480	mV
		$V_I = 30$ to 36 V, $T_J = 25^\circ\text{C}$			240	
$\Delta V_O^{(1)}$	Load regulation	$I_O = 5$ mA to 1.5 A, $T_J = 25^\circ\text{C}$			480	mV
		$I_O = 250$ to 750 mA, $T_J = 25^\circ\text{C}$			240	
I_d	Quiescent current	$T_J = 25^\circ\text{C}$			8	mA
ΔI_d	Quiescent current change	$I_O = 5$ mA to 1 A			0.5	mA
		$V_I = 27$ to 38 V			1	
$\Delta V_O/\Delta T$	Output voltage drift	$I_O = 5$ mA		-1.5		mV/°C
eN	Output noise voltage	B = 10 Hz to 100 kHz, $T_J = 25^\circ\text{C}$		170		$\mu\text{V}/V_O$
SVR	Supply voltage rejection	$V_I = 28$ to 38 V, $f = 120$ Hz	50			dB
V_d	Dropout voltage	$I_O = 1$ A, $T_J = 25^\circ\text{C}$		2		V
R_O	Output resistance	$f = 1$ kHz		28		m Λ
I_{sc}	Short circuit current	$V_I = 35$ V, $T_J = 25^\circ\text{C}$		0.15		A
I_{scp}	Short circuit peak current	$T_J = 25^\circ\text{C}$		2.1		A

1. Load and line regulation are specified at constant junction temperature. Changes in V_O due to heating effects must be taken into account separately. Pulse testing with low duty cycle is used.

6 Application information

6.1 Design consideration

The L78xx Series of fixed voltage regulators are designed with thermal overload protection that shuts down the circuit when subjected to an excessive power overload condition, internal short-circuit protection that limits the maximum current the circuit will pass, and output transistor safe-area compensation that reduces the output short-circuit current as the voltage across the pass transistor is increased. In many low current applications, compensation capacitors are not required. However, it is recommended that the regulator input be bypassed with capacitor if the regulator is connected to the power supply filter with long lengths, or if the output load capacitance is large. An input bypass capacitor should be selected to provide good high frequency characteristics to insure stable operation under all load conditions. A 0.33 μF or larger tantalum, mylar or other capacitor having low internal impedance at high frequencies should be chosen. The bypass capacitor should be mounted with the shortest possible leads directly across the regulators input terminals. Normally good construction techniques should be used to minimize ground loops and lead resistance drops since the regulator has no external sense lead.

The addition of an operational amplifier allows adjustment to higher or intermediate values while retaining regulation characteristics. The minimum voltage obtained with the arrangement is 2 V greater than the regulator voltage.

The circuit of [Figure 13](#) can be modified to provide supply protection against short circuit by adding a short circuit sense resistor, RSC, and an additional PNP transistor. The current sensing PNP must be able to handle the short circuit current of the three terminal regulator. Therefore a four ampere plastic power transistor is specified.

Figure 8. Fixed output regulator

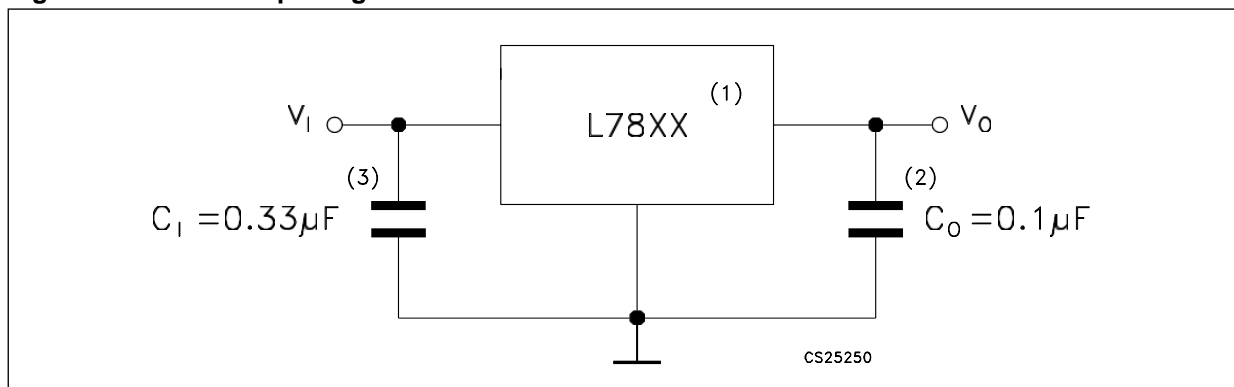

1. To specify an output voltage, substitute voltage value for "XX".
2. Although no output capacitor is need for stability, it does improve transient response.
3. Required if regulator is locate an appreciable distance from power supply filter.

Figure 9. Current regulator

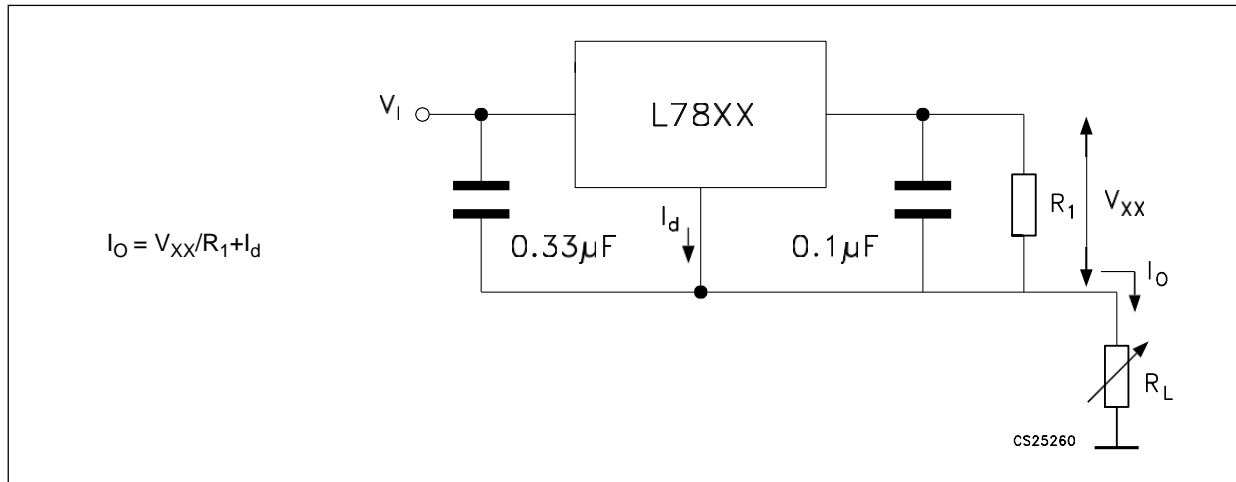

Figure 10. Circuit for increasing output voltage

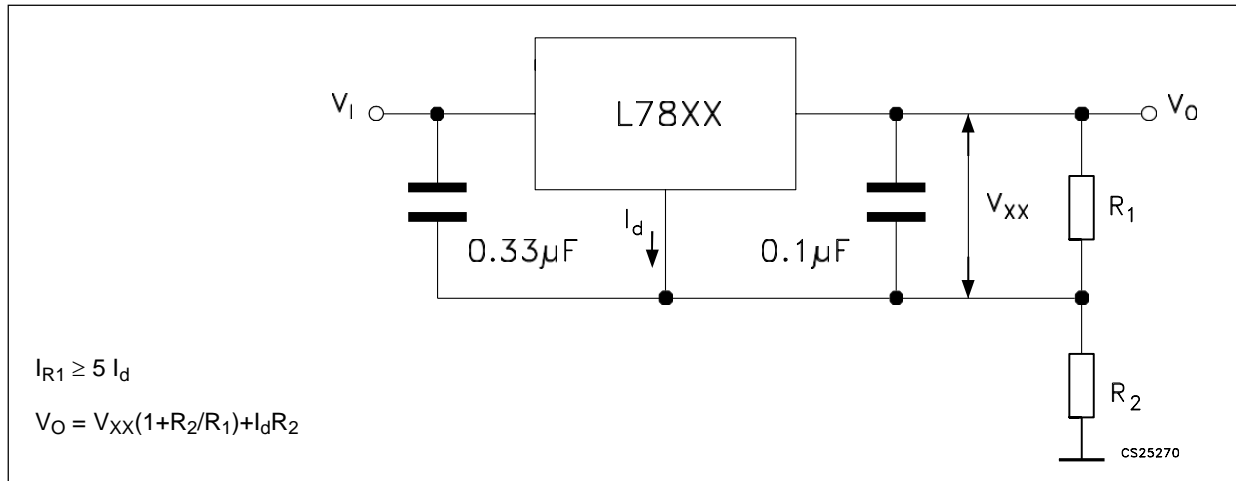

Figure 11. Adjustable output regulator (7 to 30 V)

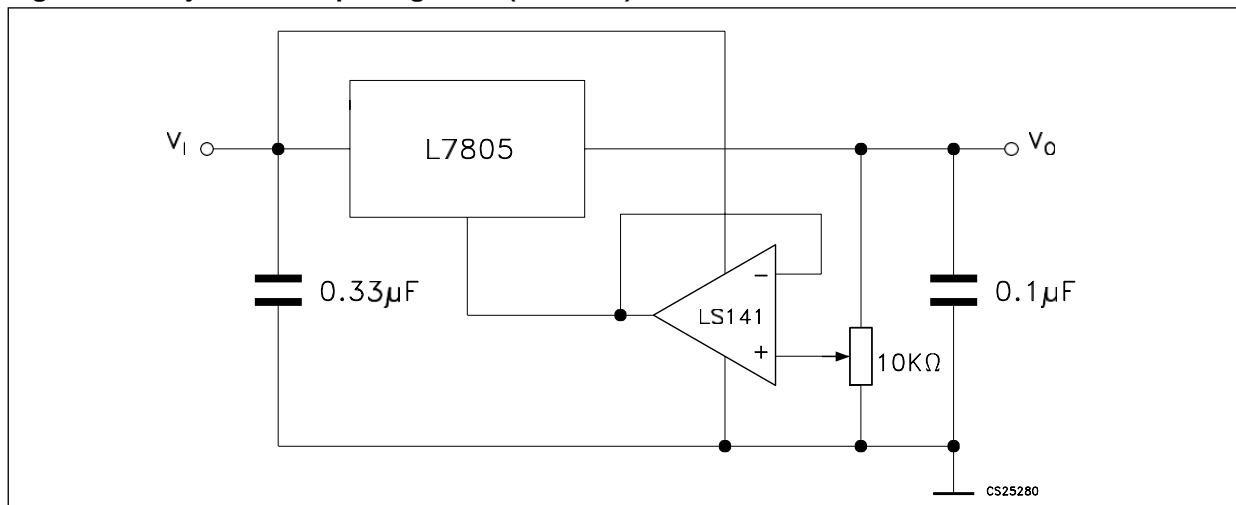

Figure 12. 0.5 to 10 V regulator

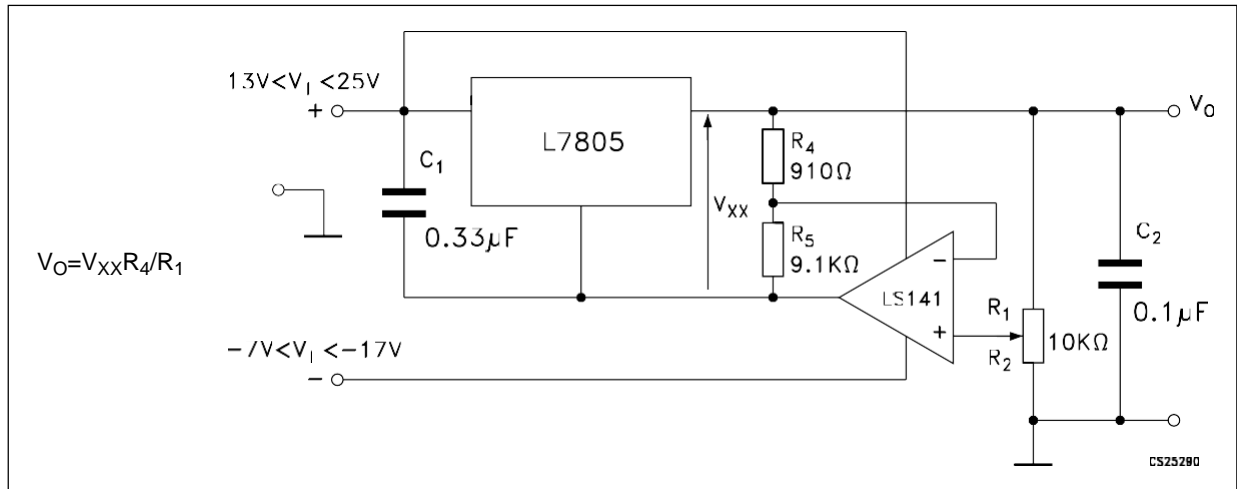

Figure 13. High current voltage regulator

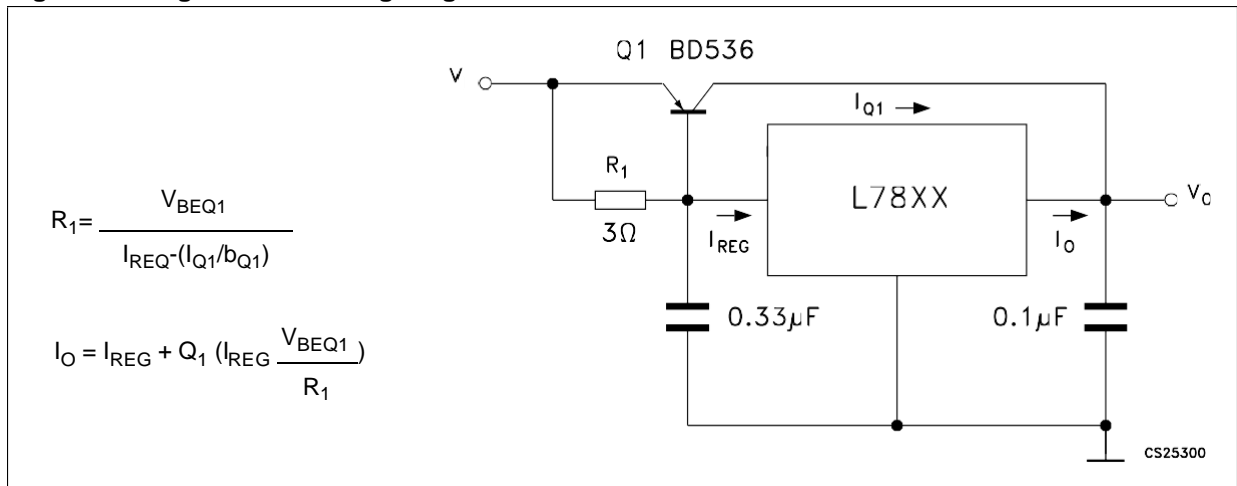

Figure 14. High output current with short circuit protection

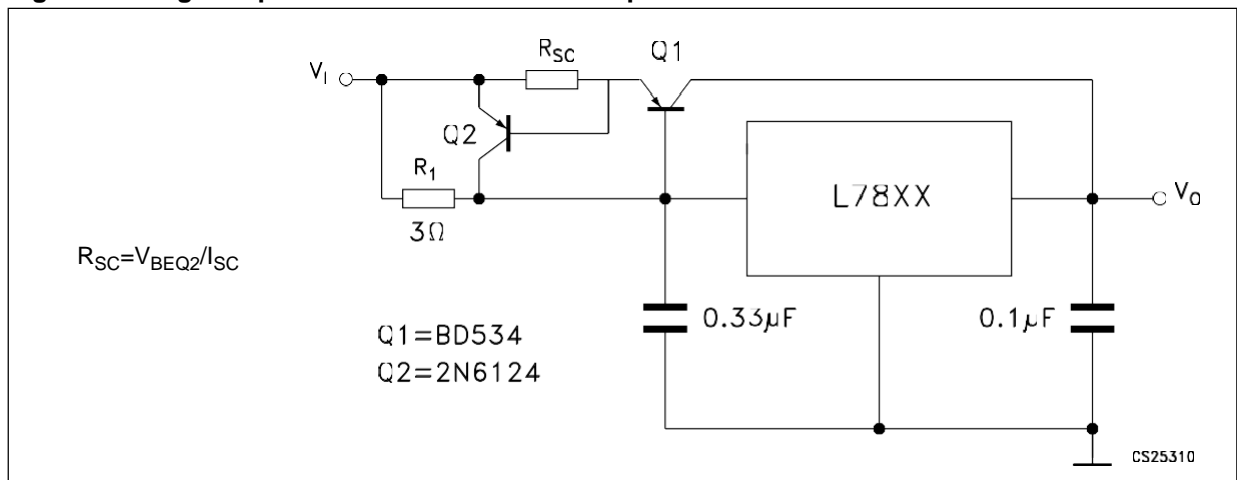

Figure 15. Tracking voltage regulator

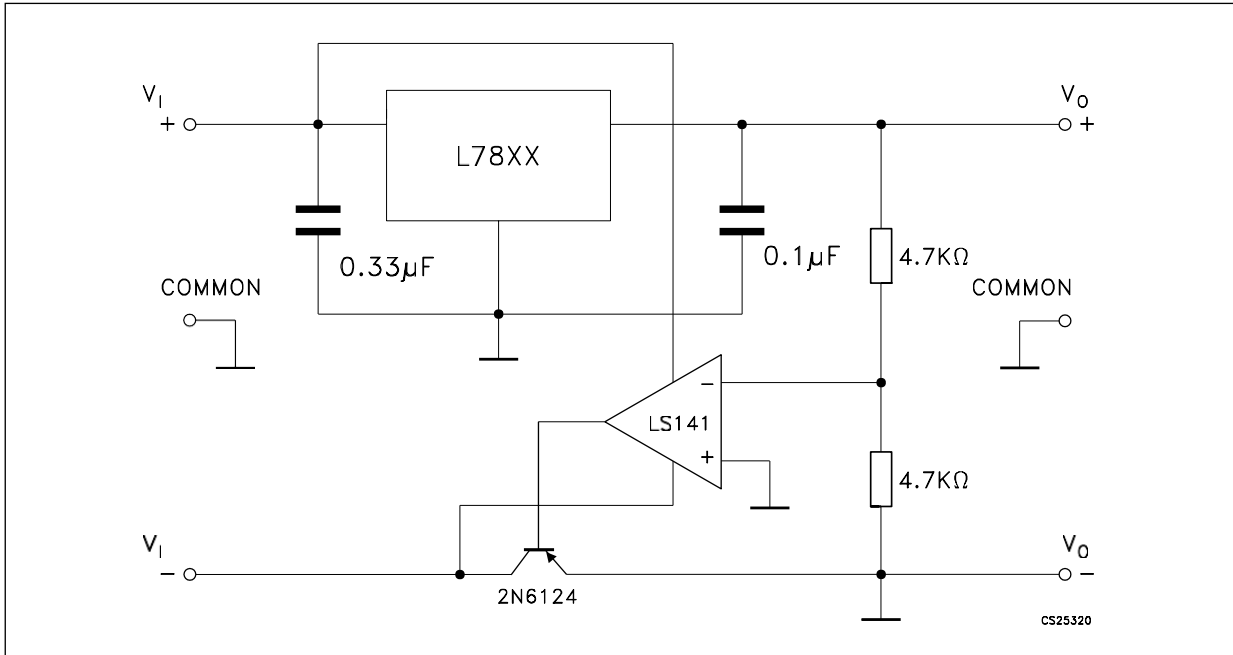
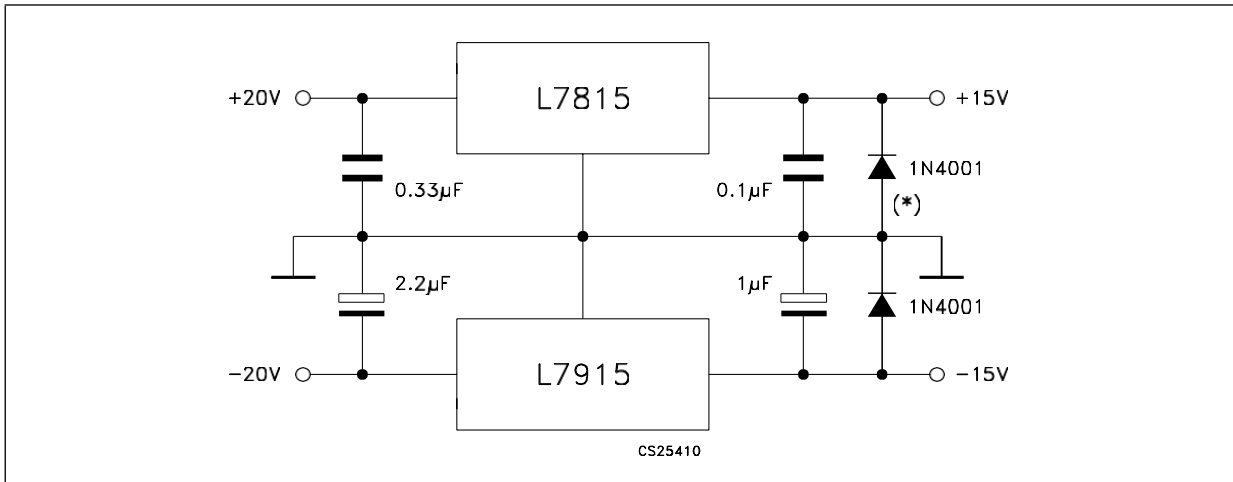

Figure 16. Split power supply (± 15 V - 1 A)



* Against potential latch-up problems.

Figure 17. Negative output voltage circuit

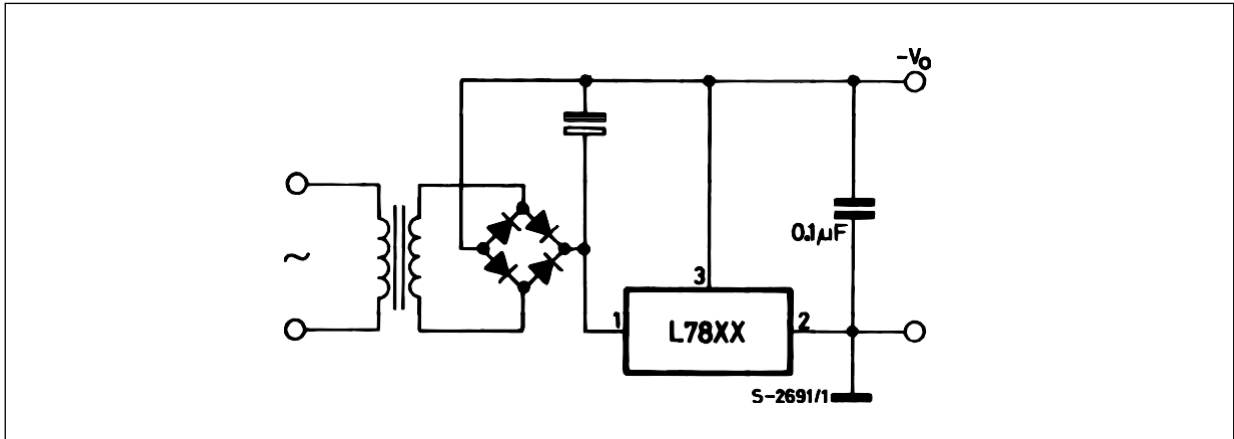

Figure 18. Switching regulator

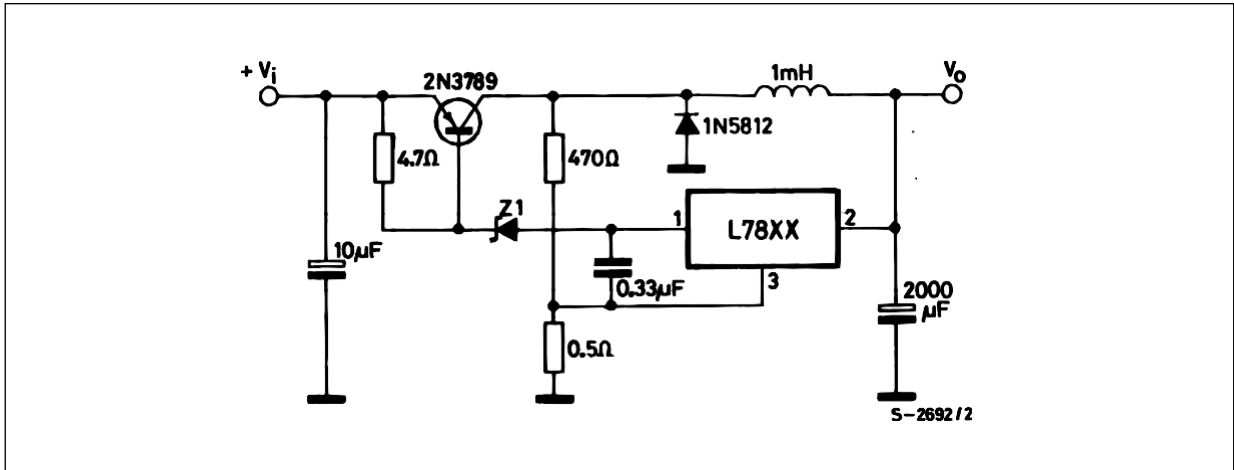

Figure 19. High input voltage circuit (configuration 1)

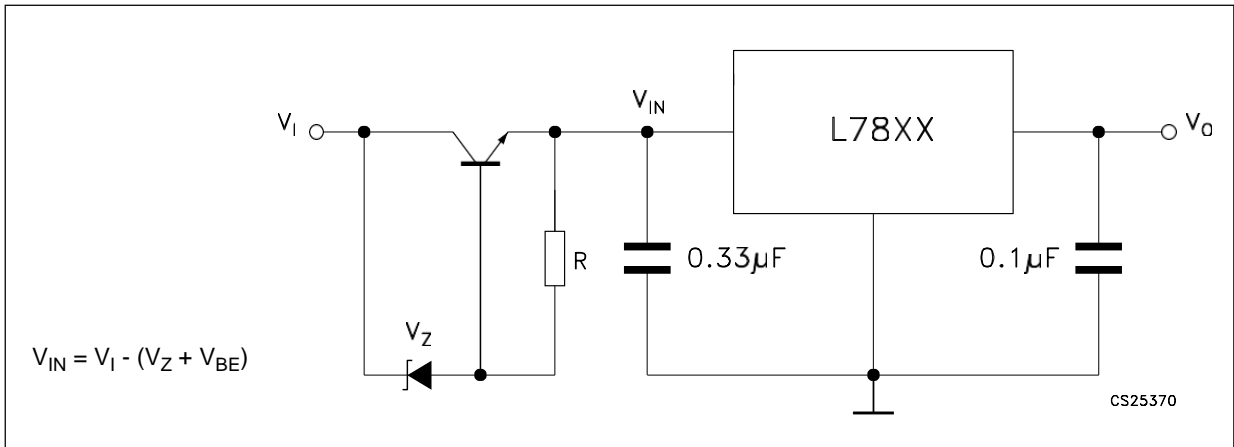

Figure 20. High input voltage circuit (configuration 2)

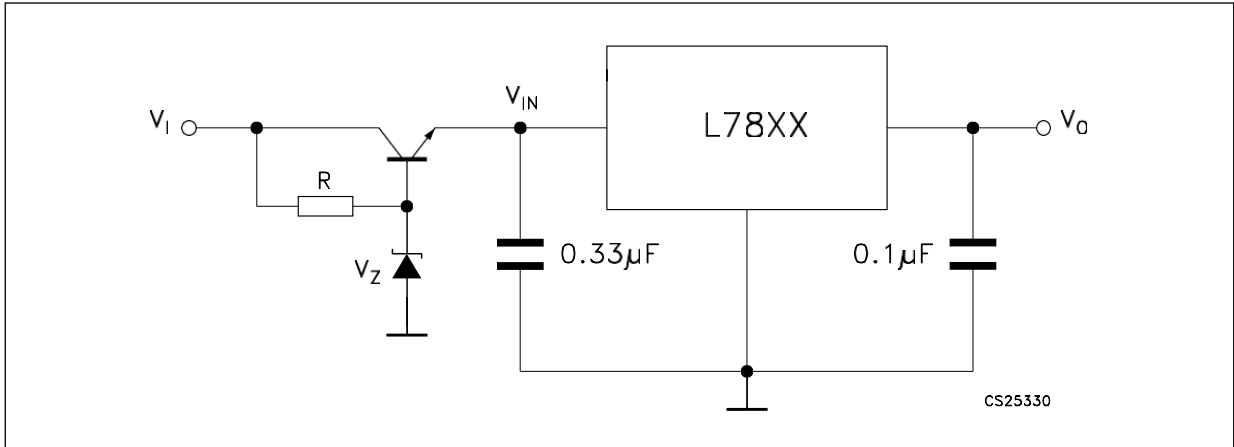

Figure 21. High output voltage regulator

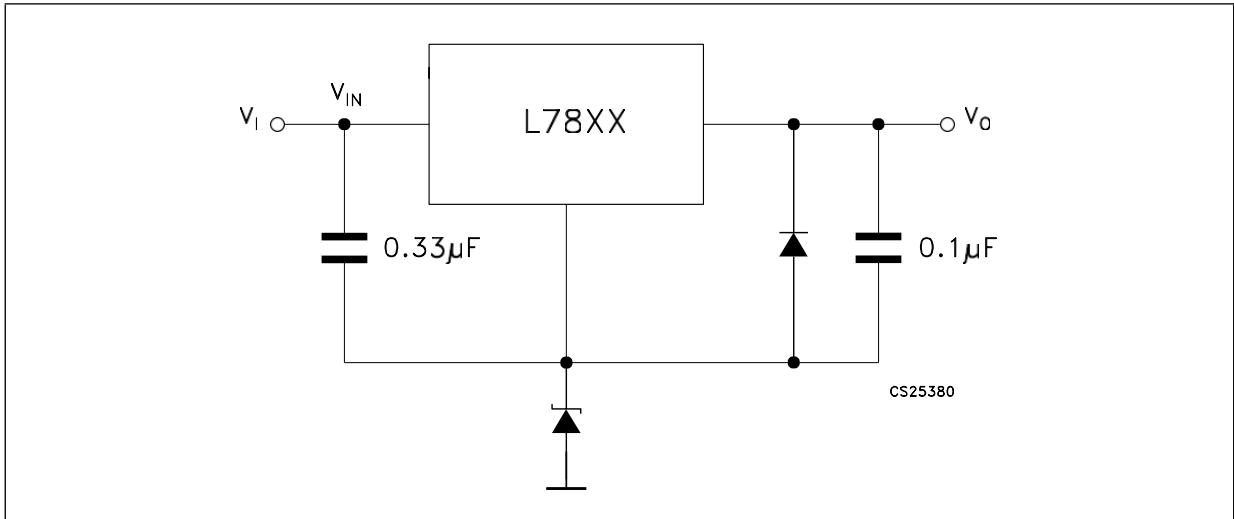

Figure 22. High input and output voltage

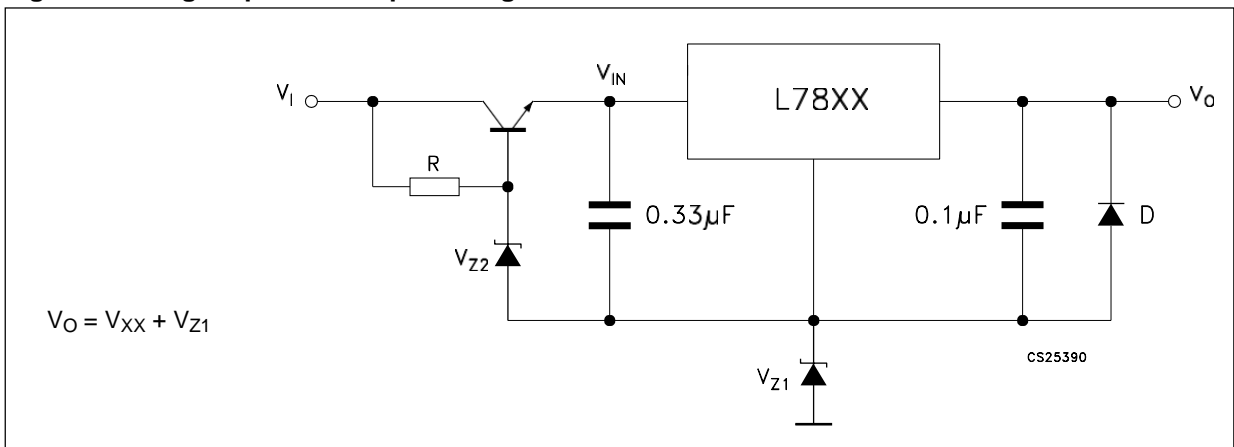

Figure 23. Reducing power dissipation with dropping resistor

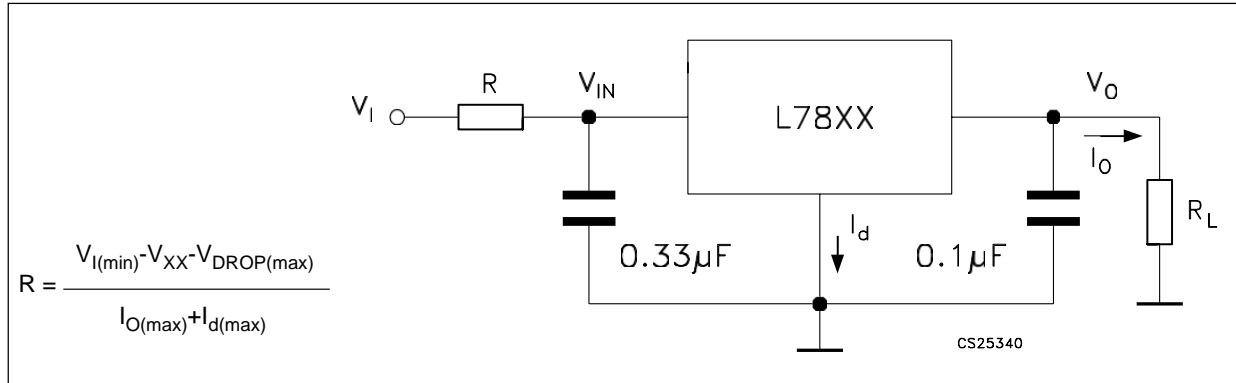

Figure 24. Remote shutdown

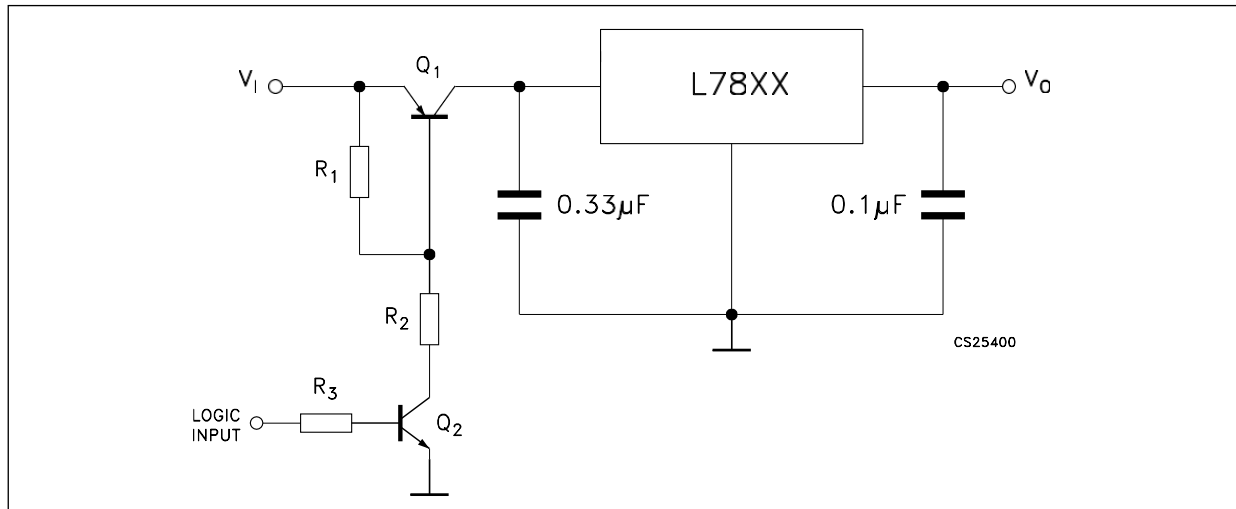
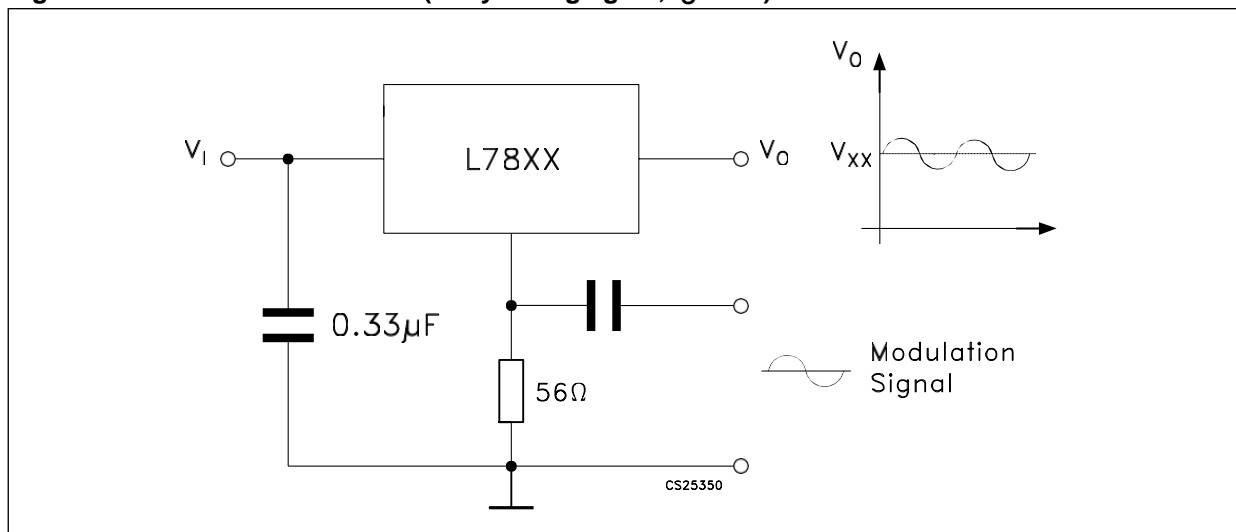
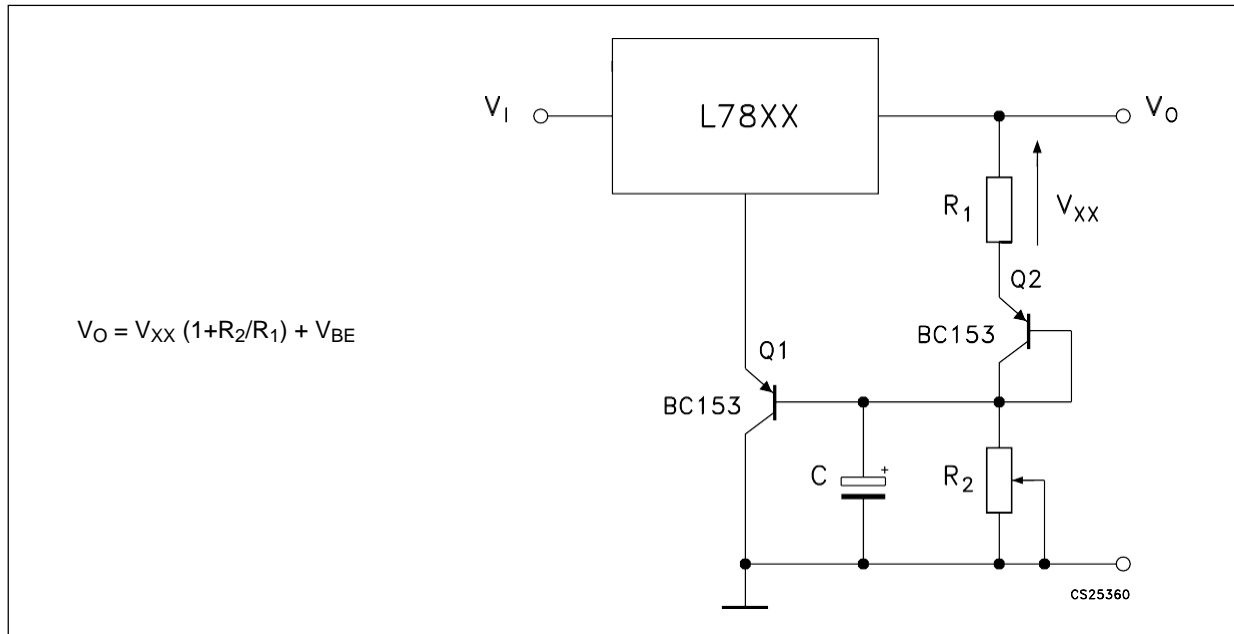

Figure 25. Power AM modulator (unity voltage gain, $I_O \leq 0.5$)



Note: The circuit performs well up to 100 kHz.

Figure 26. Adjustable output voltage with temperature compensation



Note: Q_2 is connected as a diode in order to compensate the variation of the Q_1 V_{BE} with the temperature. C allows a slow rise time of the V_O .

Figure 27. Light controllers ($V_{O(min)} = V_{XX} + V_{BE}$)

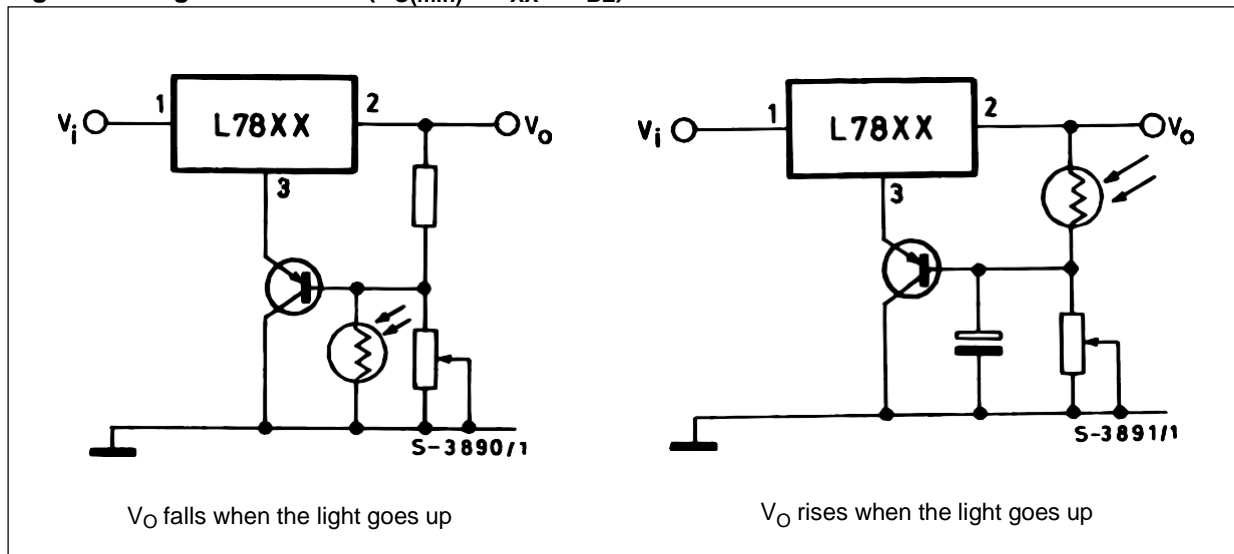
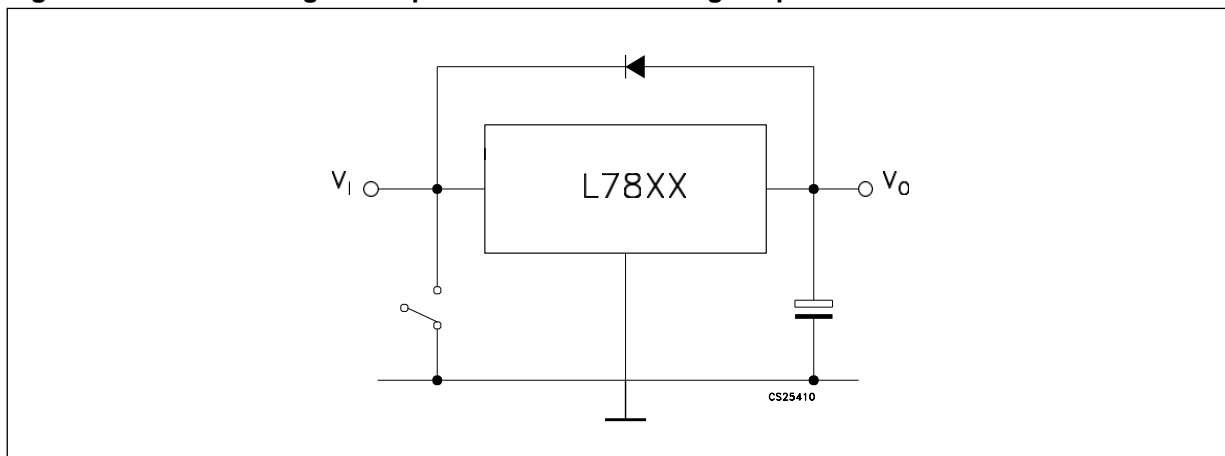

Figure 28. Protection against input short-circuit with high capacitance loads



Note: Application with high capacitance loads and an output voltage greater than 6 volts need an external diode (see [Figure 23 on page 34](#)) to protect the device against input short circuit. In this case the input voltage falls rapidly while the output voltage decrease slowly. The capacitance discharges by means of the base-emitter junction of the series pass transistor in the regulator. If the energy is sufficiently high, the transistor may be destroyed. The external diode by-passes the current from the IC to ground.

7 Typical performance

Figure 29. Dropout voltage vs. junction temperature

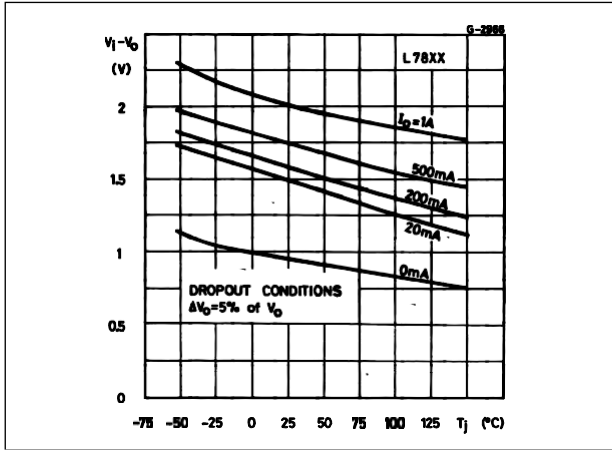

Figure 30. Peak output current vs. input/output differential voltage

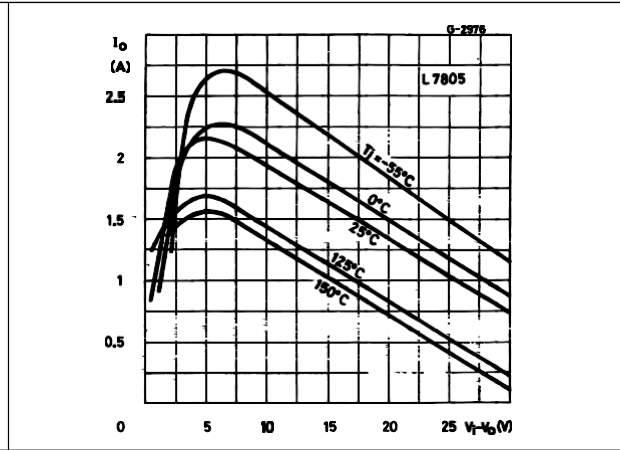

Figure 31. Supply voltage rejection vs. frequency

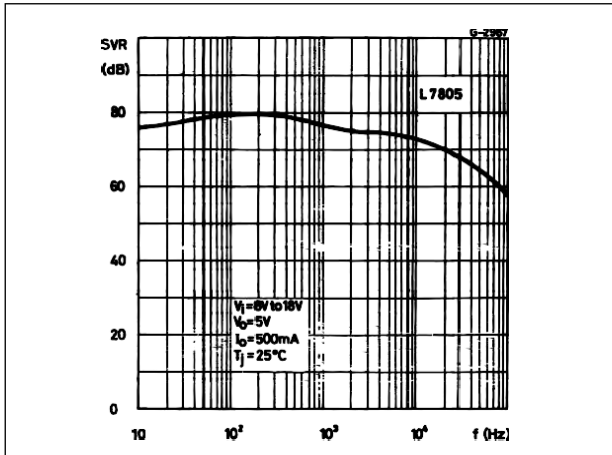

Figure 32. Output voltage vs. junction temperature

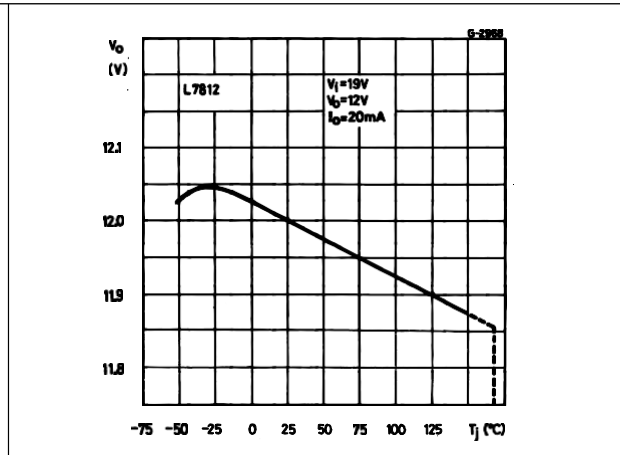

Figure 33. Output impedance vs. frequency

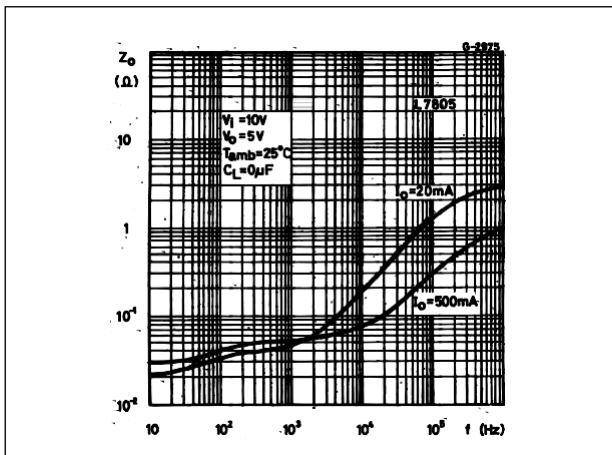

Figure 34. Quiescent current vs. junction temp.

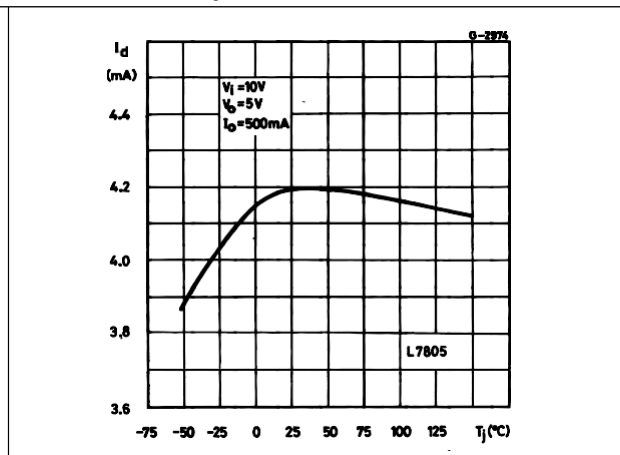

Figure 35. Load transient response

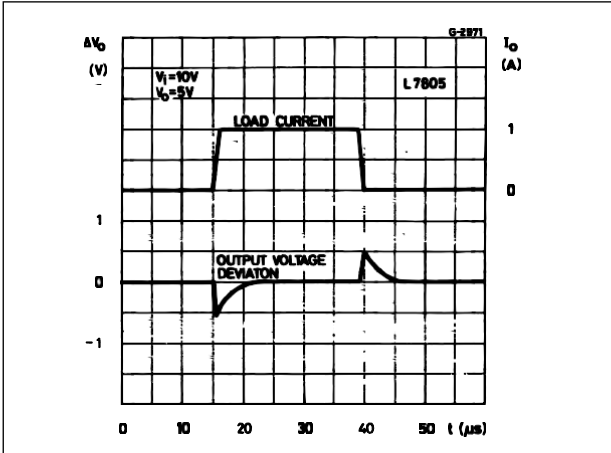

Figure 36. Line transient response

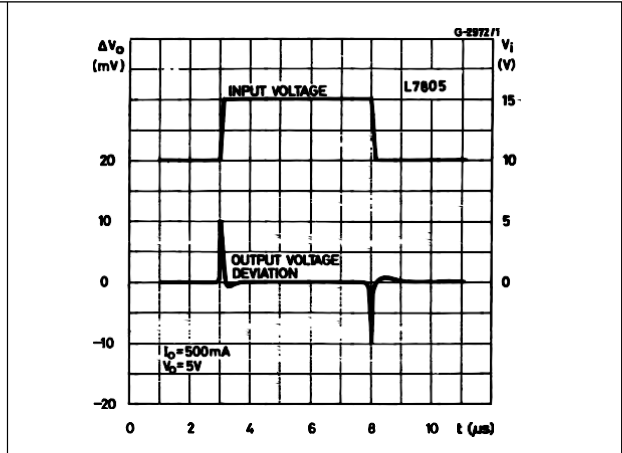
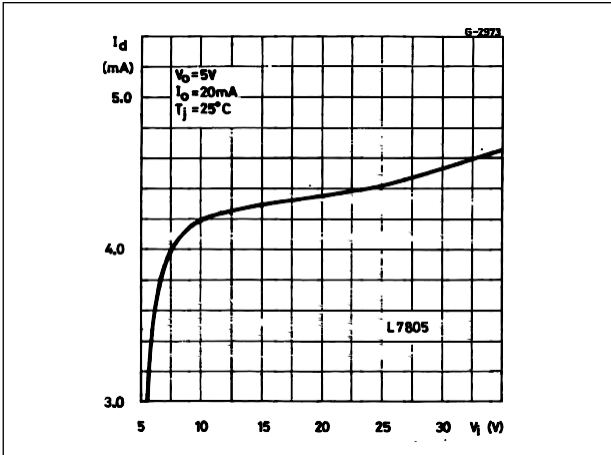

Figure 37. Quiescent current vs. input voltage



8 Package mechanical data

In order to meet environmental requirements, ST offers these devices in different grades of ECOPACK® packages, depending on their level of environmental compliance. ECOPACK® specifications, grade definitions and product status are available at: www.st.com. ECOPACK® is an ST trademark.

Table 23. TO-220 mechanical data

Dim.	Type STD - ST Dual Gauge			Type STD - ST Single Gauge		
	mm.			mm.		
	Min.	Typ.	Max.	Min.	Typ.	Max.
A	4.40		4.60	4.40		4.60
b	0.61		0.88	0.61		0.88
b1	1.14		1.70	1.14		1.70
c	0.48		0.70	0.48		0.70
D	15.25		15.75	15.25		15.75
D1		1.27				
E	10.00		10.40	10.00		10.40
e	2.40		2.70	2.40		2.70
e1	4.95		5.15	4.95		5.15
F	1.23		1.32	0.51		0.60
H1	6.20		6.60	6.20		6.60
J1	2.40		2.72	2.40		2.72
L	13.00		14.00	13.00		14.00
L1	3.50		3.93	3.50		3.93
L20		16.40			16.40	
L30		28.90			28.90	
∅P	3.75		3.85	3.75		3.85
Q	2.65		2.95	2.65		2.95

In spite of some difference in tolerances, the packages are compatible.

Figure 38. Drawing dimension TO-220 (type STD-ST Dual Gauge)

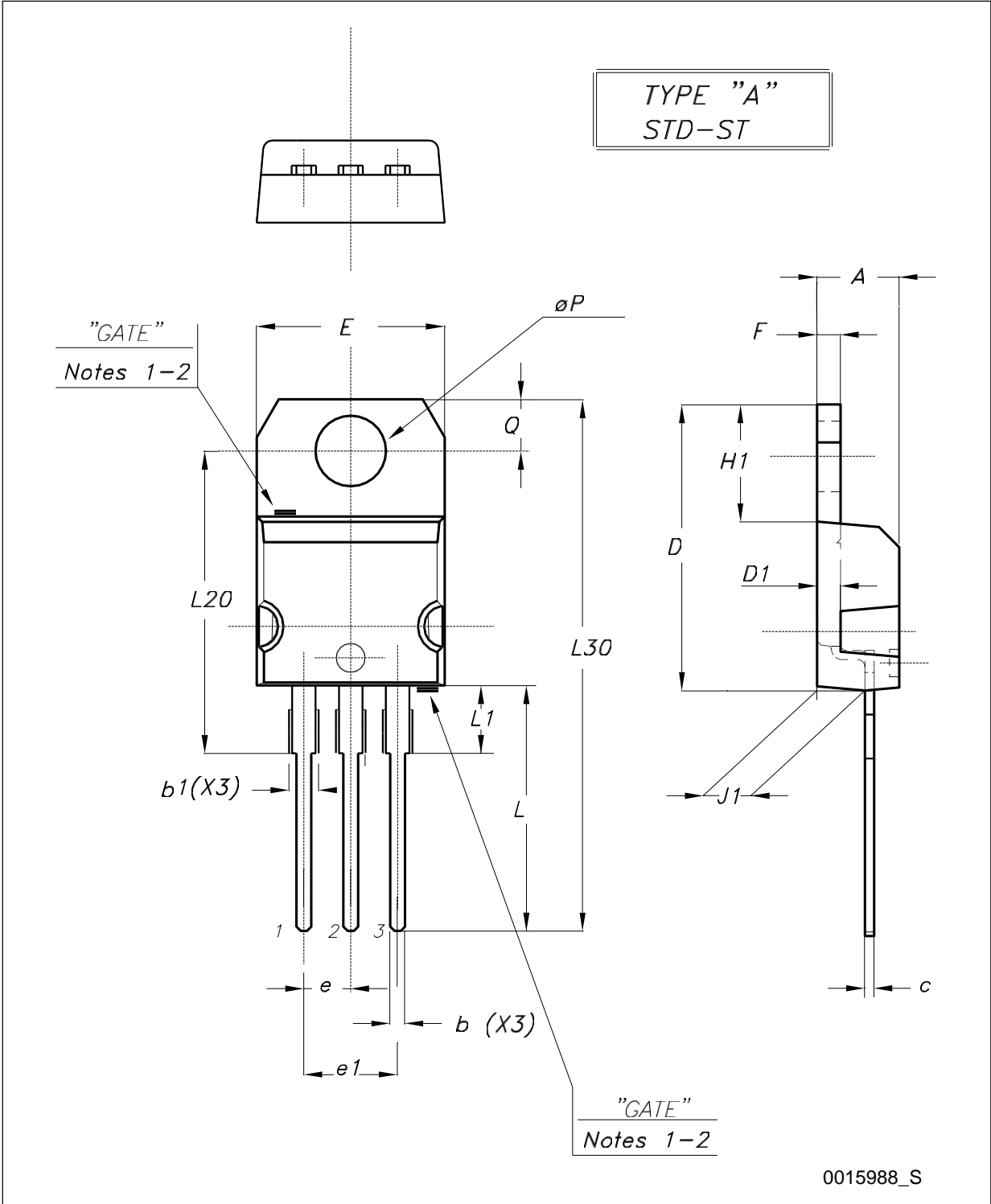

- Note: 1 Maximum resin gate protrusion: 0.5 mm.
- 2 Resin gate position is accepted in each of the two positions shown on the drawing, or their symmetrical.

Figure 39. Drawing dimension TO-220 (type STD-ST Single Gauge)

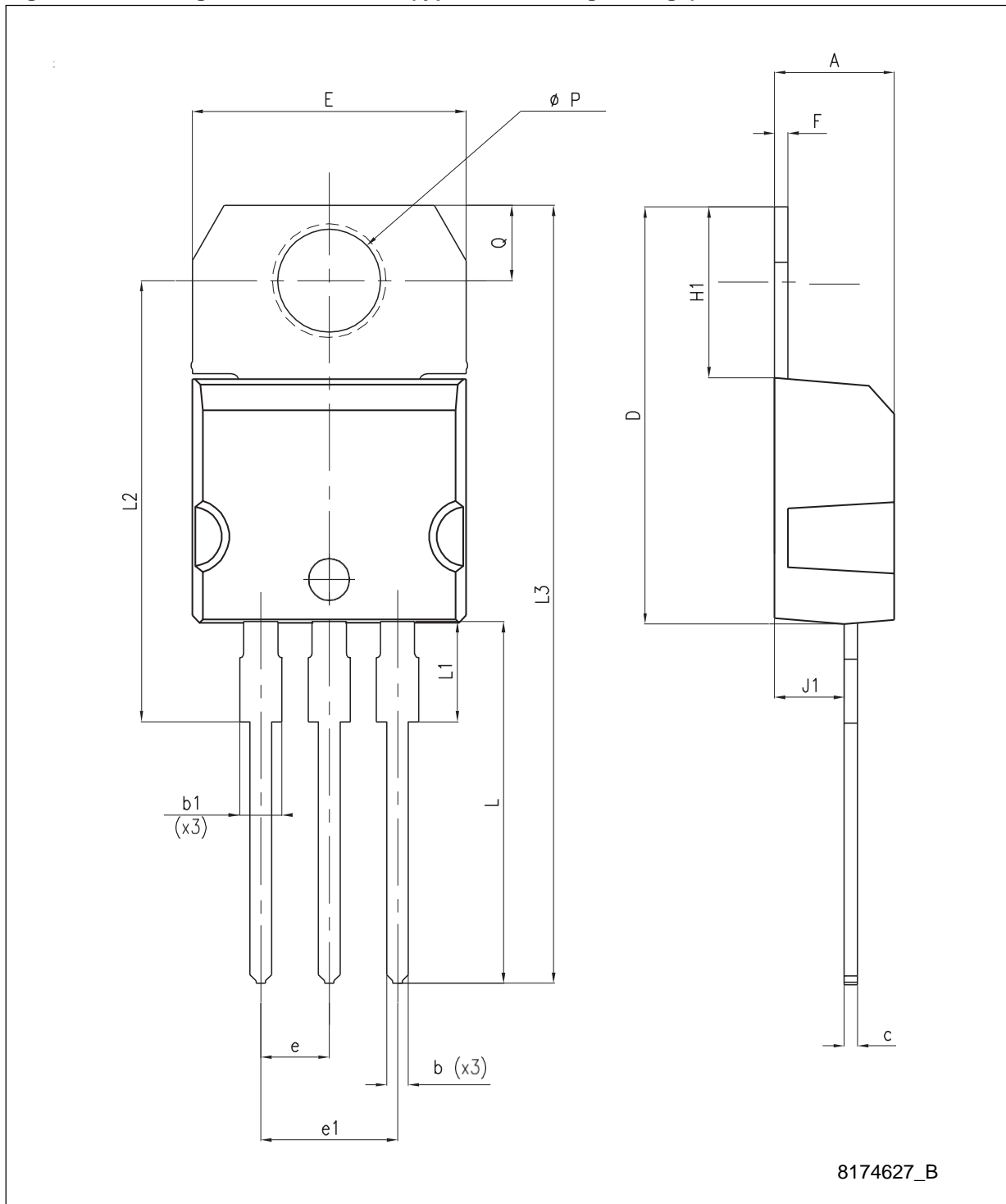

Figure 40. Drawing dimension tube for TO-220 Dual Gauge (mm.)

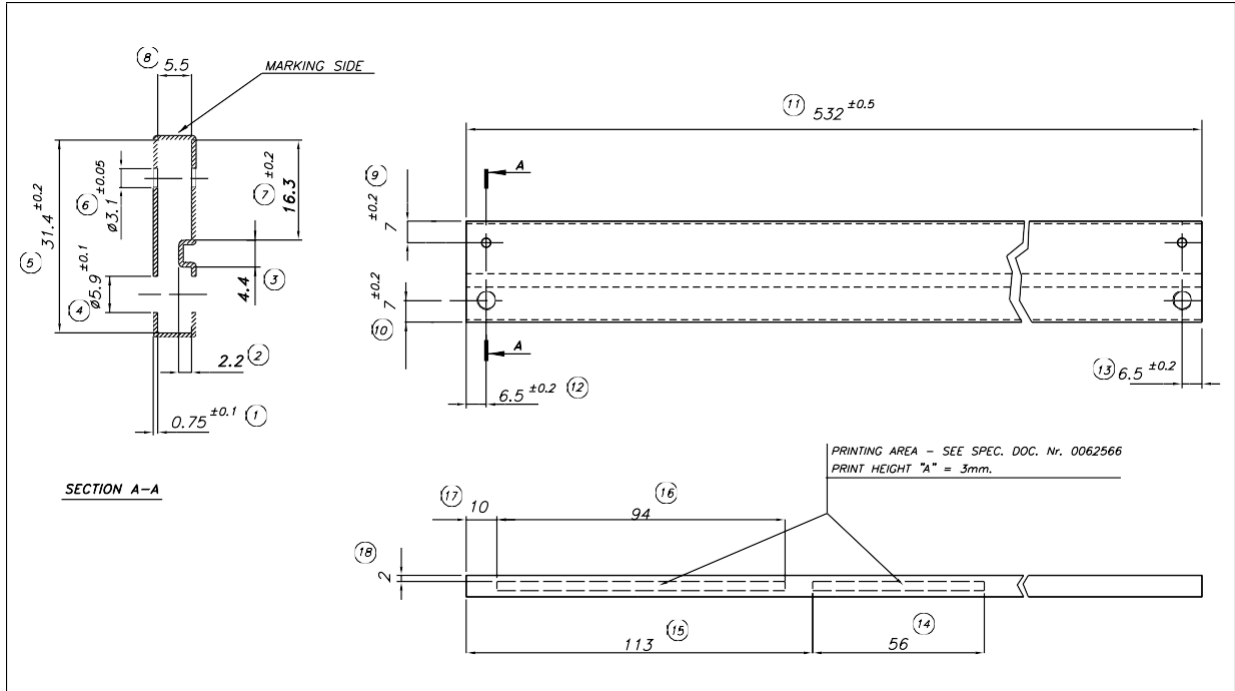

Figure 41. Drawing dimension tube for TO-220 Single Gauge (mm.)

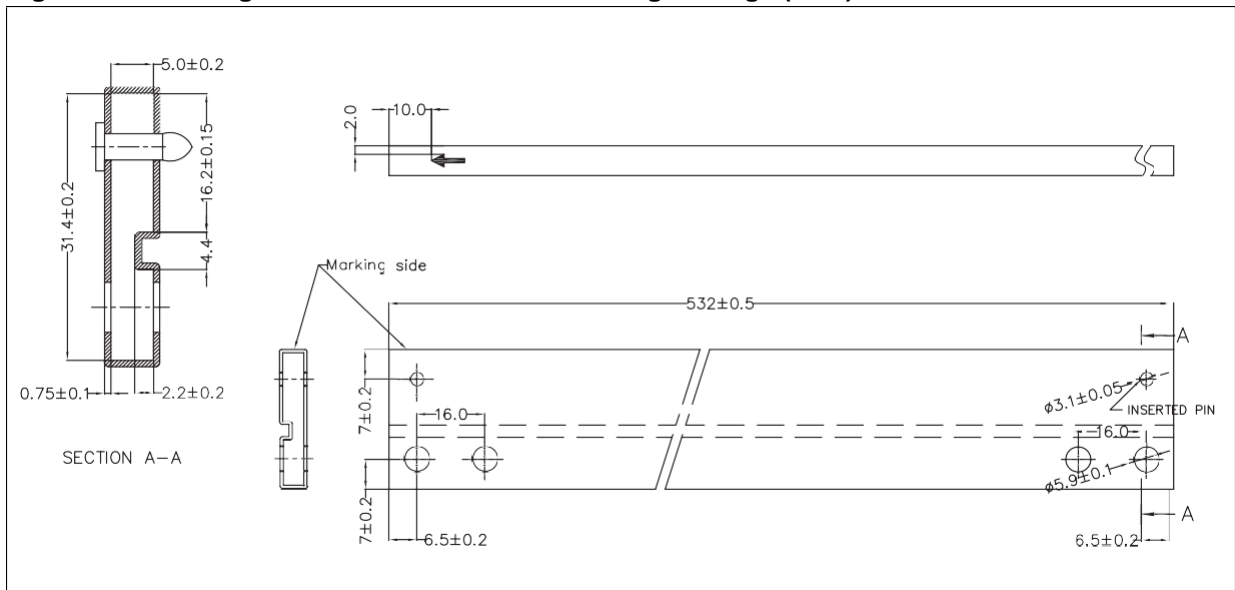
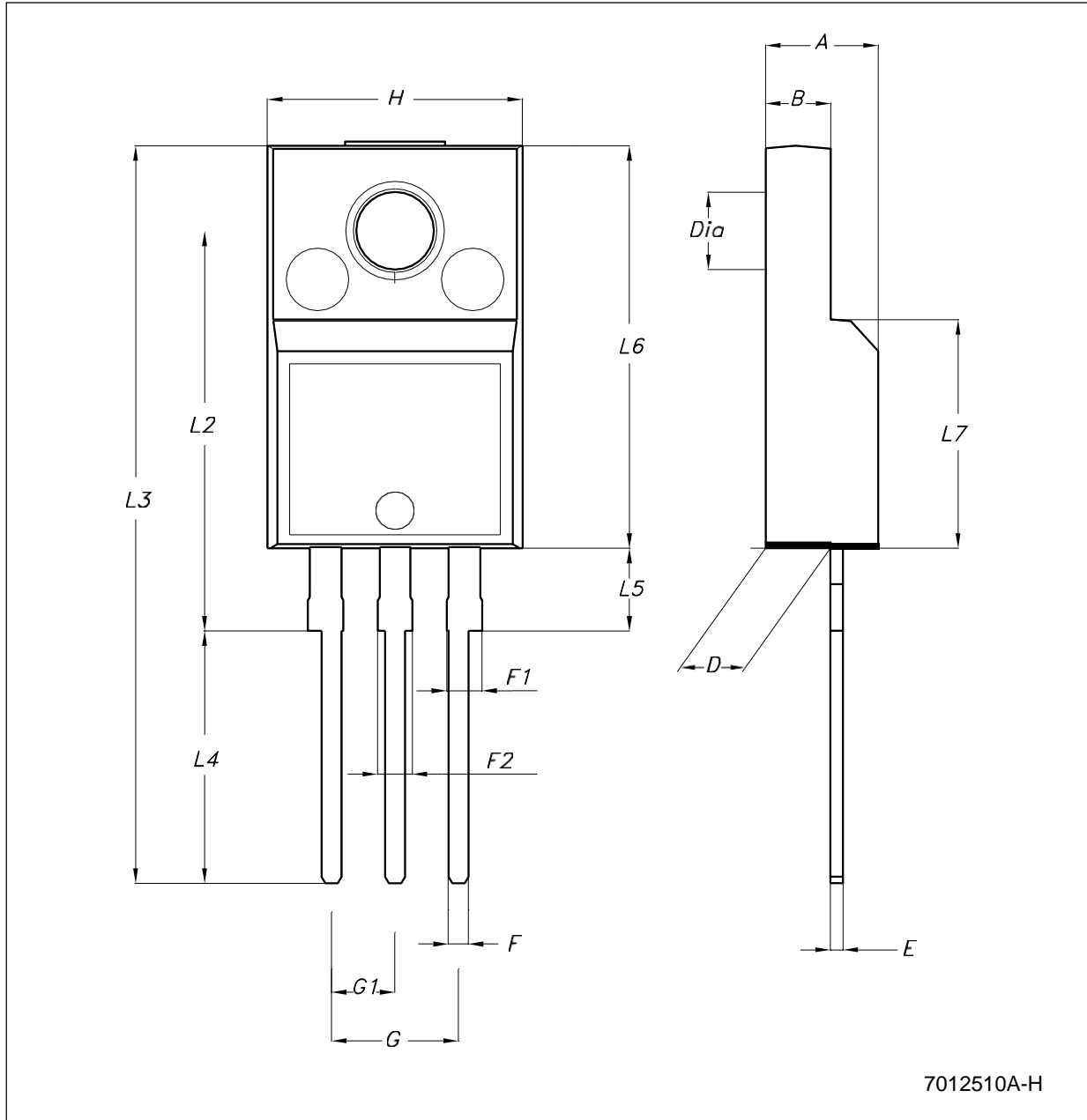

Figure 42. Drawing dimension TO-220FP



7012510A-H

Table 24. TO-220FP mechanical data

Dim.	mm.			inch.		
	Min.	Typ.	Max.	Min.	Typ.	Max.
A	4.40		4.60	0.173		0.181
B	2.5		2.7	0.098		0.106
D	2.5		2.75	0.098		0.108
E	0.45		0.70	0.017		0.027
F	0.75		1	0.030		0.039
F1	1.15		1.50	0.045		0.059
F2	1.15		1.50	0.045		0.059
G	4.95		5.2	0.194		0.204
G1	2.4		2.7	0.094		0.106
H	10.0		10.40	0.393		0.409
L2		16			0.630	
L3	28.6		30.6	1.126		1.204
L4	9.8		10.6	0.385		0.417
L5	2.9		3.6	0.114		0.142
L6	15.9		16.4	0.626		0.645
L7	9		9.3	0.354		0.366
DIA.	3		3.2	0.118		0.126

Figure 43. Drawing dimension TO-3

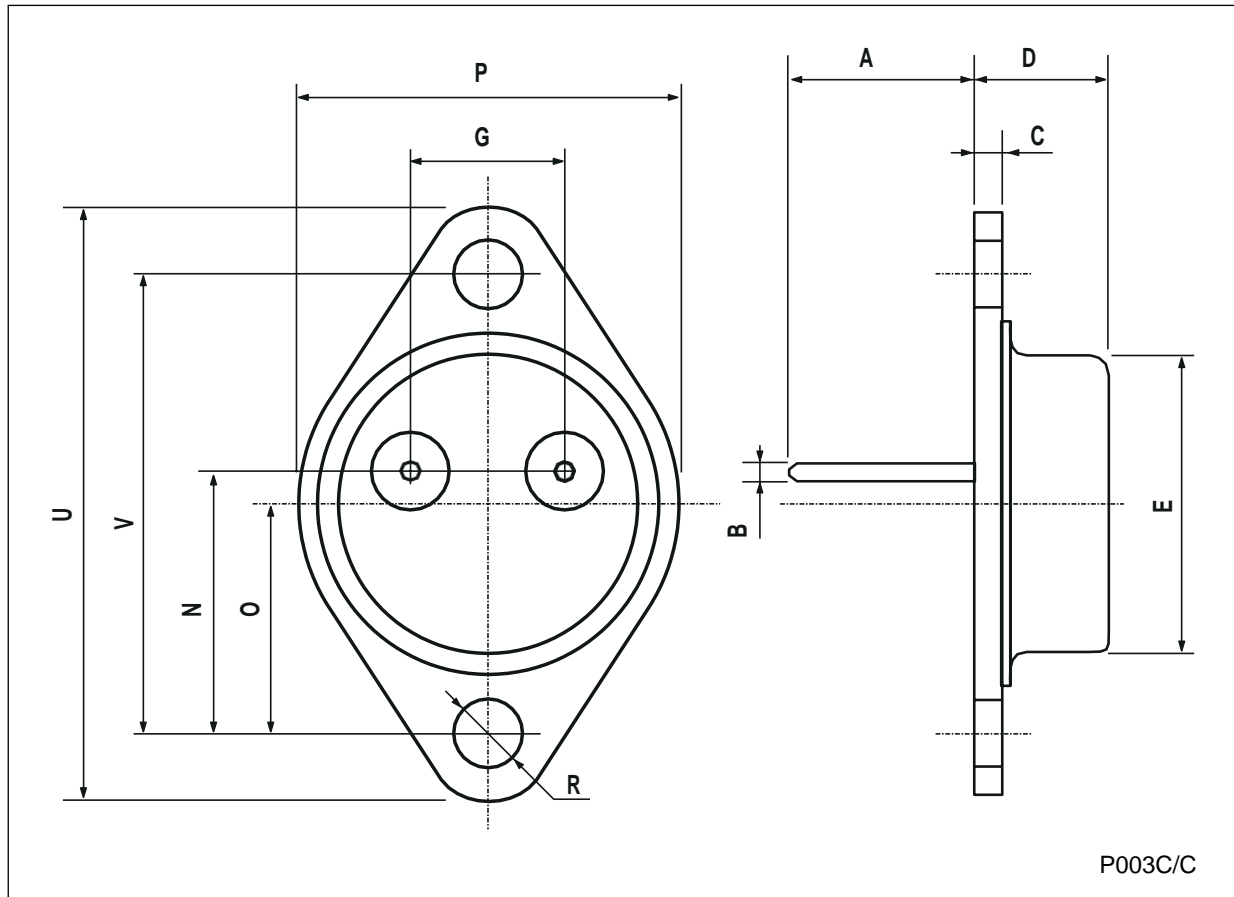

Table 25. TO-3 mechanical data

Dim.	mm.			inch.		
	Min.	Typ.	Max.	Min.	Typ.	Max.
A		11.85			0.466	
B	0.96	1.05	1.10	0.037	0.041	0.043
C			1.70			0.066
D			8.7			0.342
E			20.0			0.787
G		10.9			0.429	
N		16.9			0.665	
P			26.2			1.031
R	3.88		4.09	0.152		0.161
U			39.5			1.555
V		30.10			1.185	

Figure 44. Drawing dimension DPAK

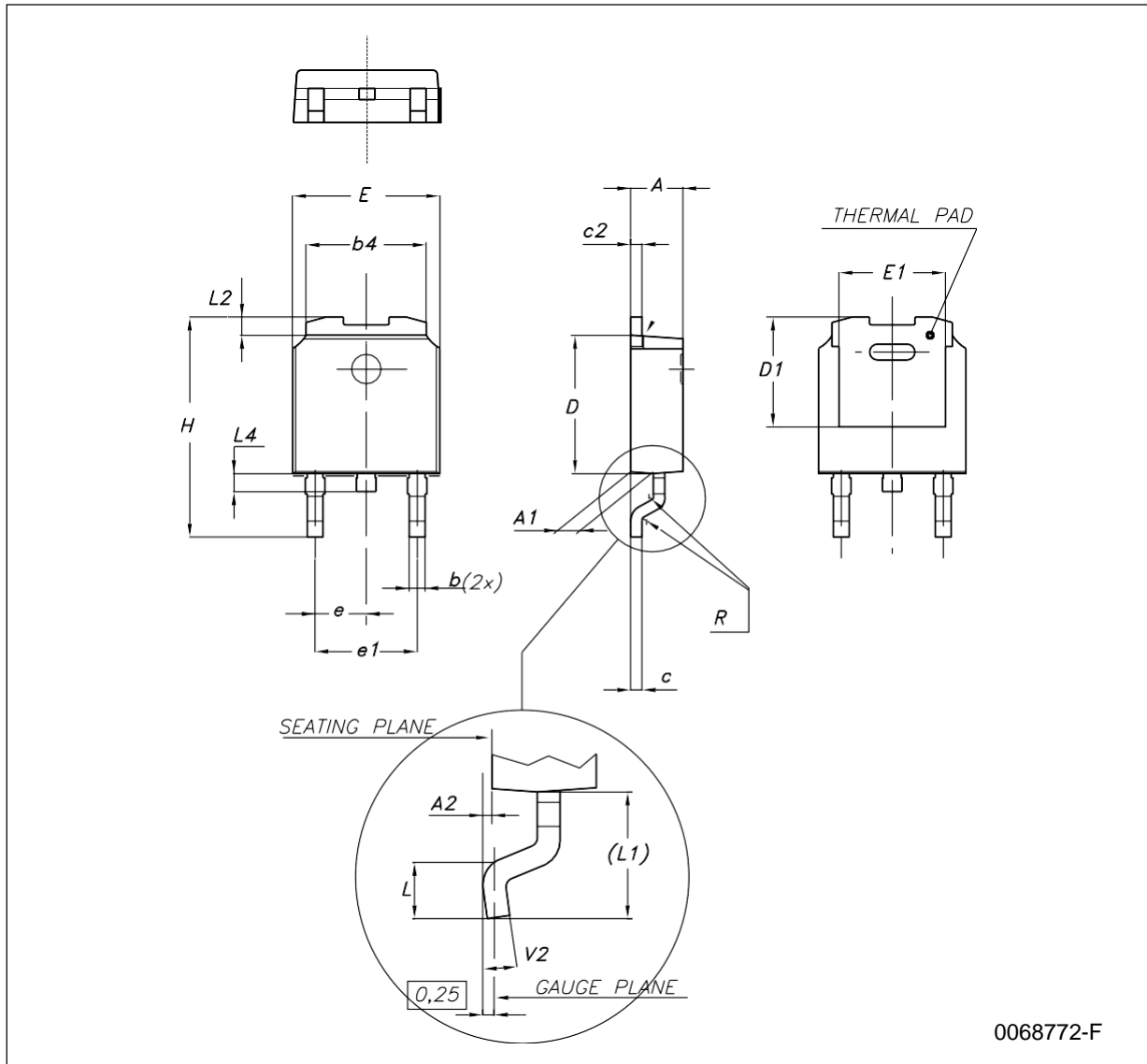

Table 26. DPAK mechanical data

Dim.	mm.			inch.		
	Min.	Typ.	Max.	Min.	Typ.	Max.
A	2.2		2.4	0.086		0.094
A1	0.9		1.1	0.035		0.043
A2	0.03		0.23	0.001		0.009
B	0.64		0.9	0.025		0.035
b4	5.2		5.4	0.204		0.212
C	0.45		0.6	0.017		0.023
C2	0.48		0.6	0.019		0.023
D	6		6.2	0.236		0.244
D1		5.1			0.200	
E	6.4		6.6	0.252		0.260
E1		4.7			0.185	
e		2.28			0.090	
e1	4.4		4.6	0.173		0.181
H	9.35		10.1	0.368		0.397
L	1			0.039		
(L1)		2.8			0.110	
L2		0.8			0.031	
L4	0.6		1	0.023		0.039
R		0.2			0.008	
V2	0°		8°	0°		8°

Figure 45. Drawing dimension tape and reel for DPAK

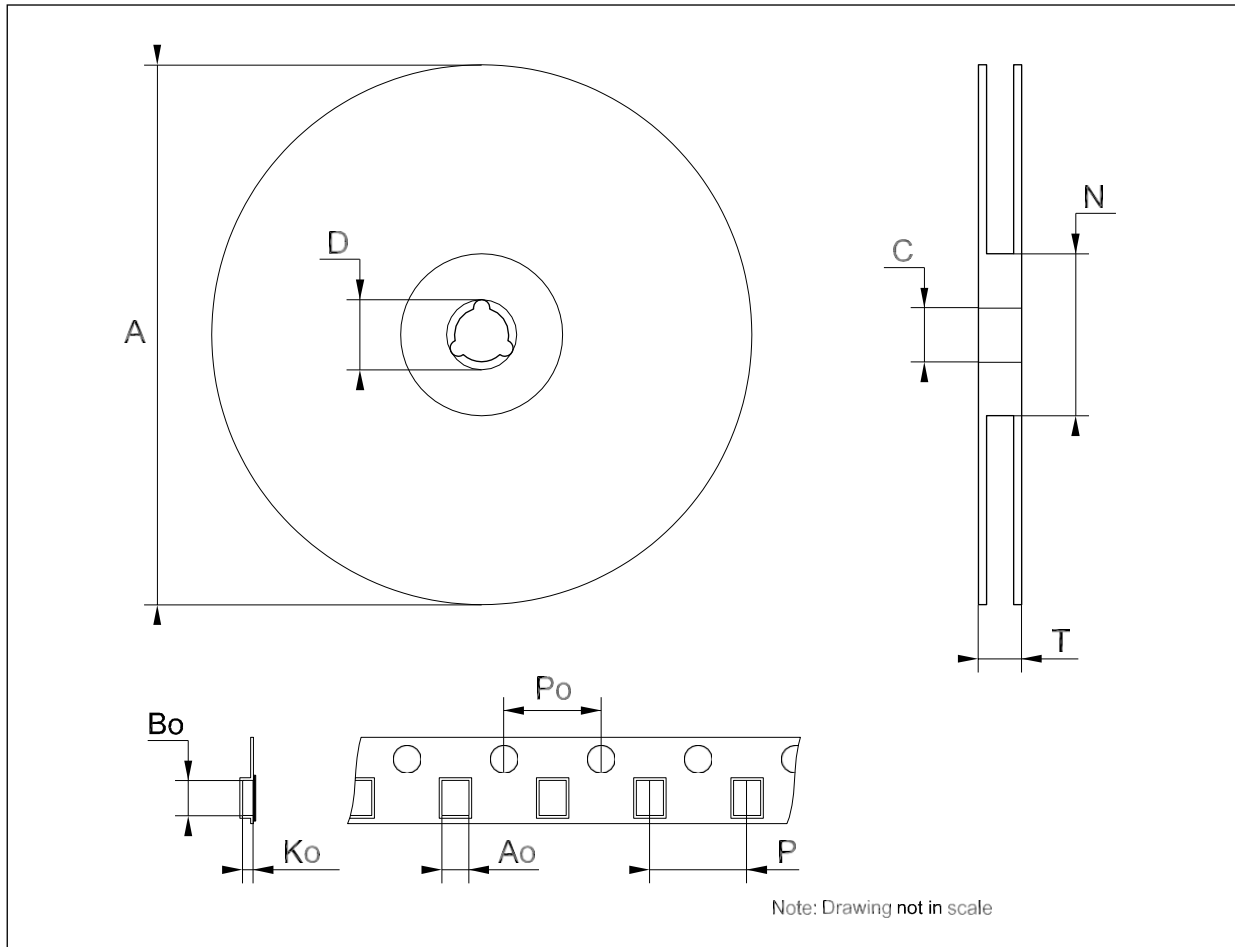

Table 27. Tape and reel DPAK mechanical data

Dim.	mm.			inch.		
	Min.	Typ.	Max.	Min.	Typ.	Max.
A			330			12.992
C	12.8	13.0	13.2	0.504	0.512	0.519
D	20.2			0.795		
N	60			2.362		
T			22.4			0.882
Ao	6.80	6.90	7.00	0.268	0.272	0.276
Bo	10.40	10.50	10.60	0.409	0.413	0.417
Ko	2.55	2.65	2.75	0.100	0.104	0.105
Po	3.9	4.0	4.1	0.153	0.157	0.161
P	7.9	8.0	8.1	0.311	0.315	0.319

Figure 46. Drawing dimension D²PAK (type STD-ST)

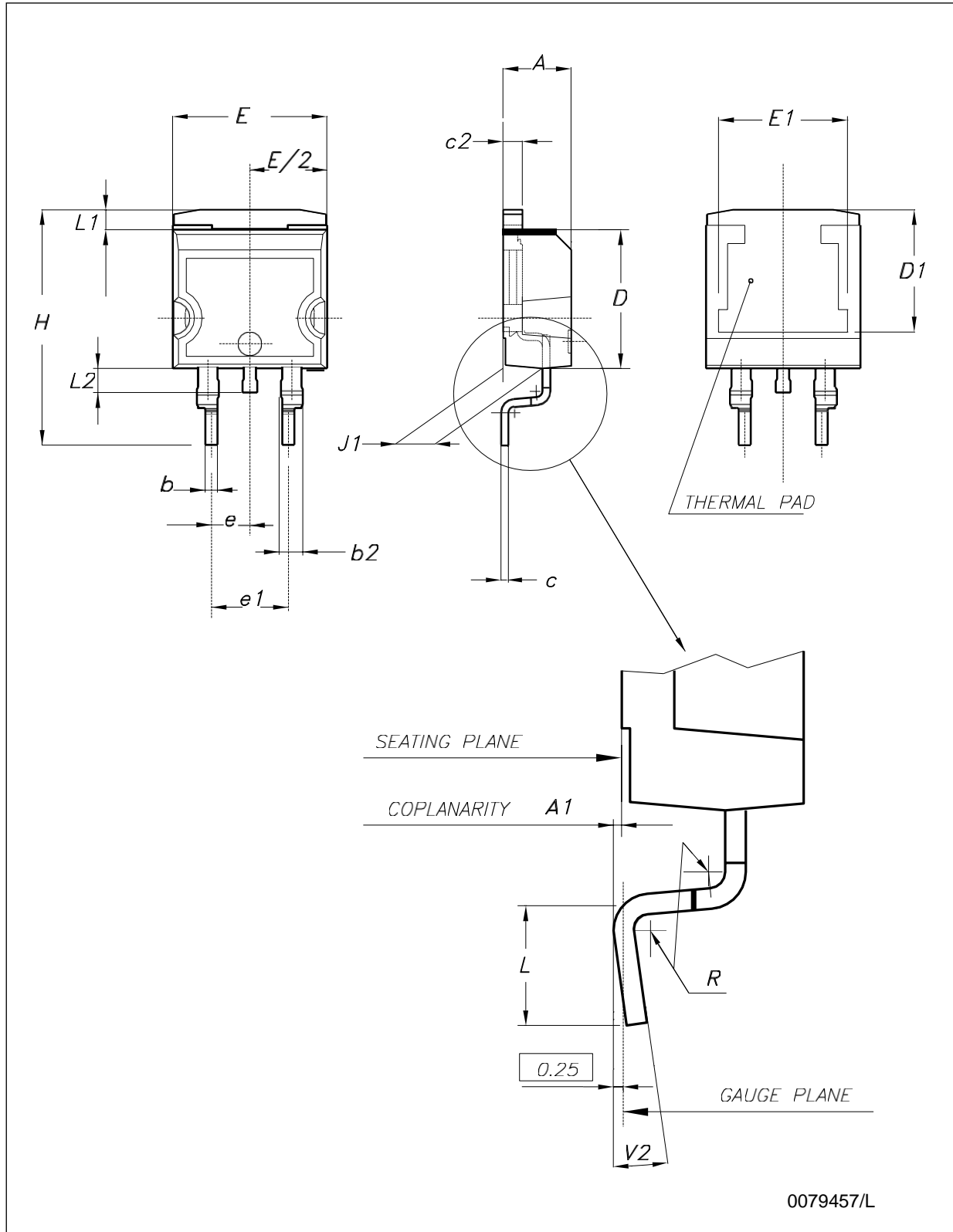

Figure 47. Drawing dimension D²PAK (type WOOSEOK-Subcon.)

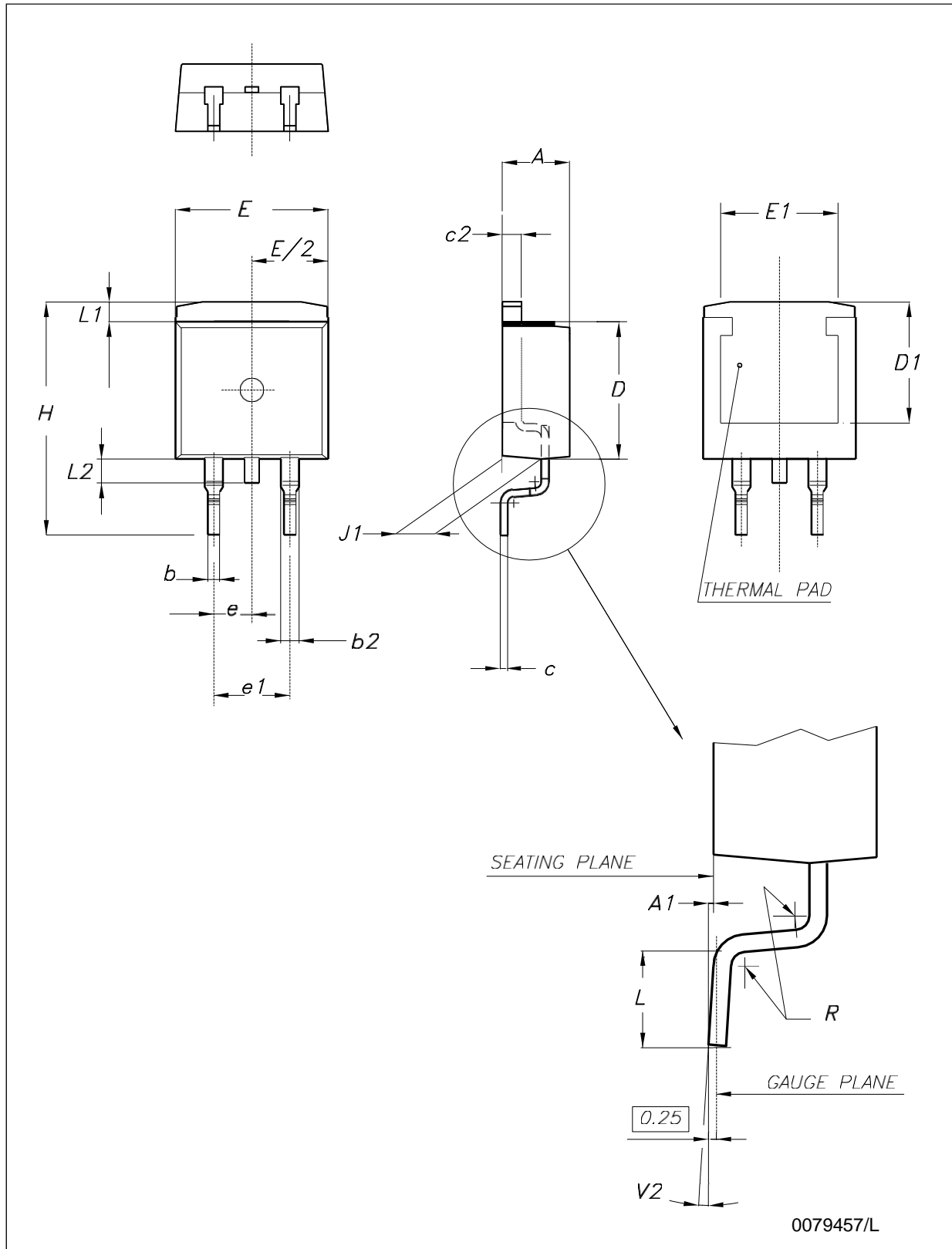

Table 28. D²PAK mechanical data

Dim.	Type STD-ST			Type WOOSEOK-Subcon.		
	mm.			mm.		
	Min.	Typ.	Max.	Min.	Typ.	Max.
A	4.40		4.60	4.30		4.70
A1	0.03		0.23	0		0.20
b	0.70		0.93	0.70		0.90
b2	1.14		1.70	1.17		1.37
c	0.45		0.60	0.45	0.50	0.60
c2	1.23		1.36	1.25	1.30	1.40
D	8.95		9.35	9	9.20	9.40
D1	7.50			7.50		
E	10		10.40	9.80		10.20
E1	8.50			7.50		
e		2.54			2.54	
e1	4.88		5.28		5.08	
H	15		15.85	15	15.30	15.60
J1	2.49		2.69	2.20		2.60
L	2.29		2.79	1.79		2.79
L1	1.27		1.40	1		1.40
L2	1.30		1.75	1.20		1.60
R		0.4			0.30	
V2	0°		8°	0°		3°

Note: The D²PAK package coming from the subcontractor Wooseok is fully compatible with the ST's package suggested footprint.

Figure 48. D²PAK footprint recommended data

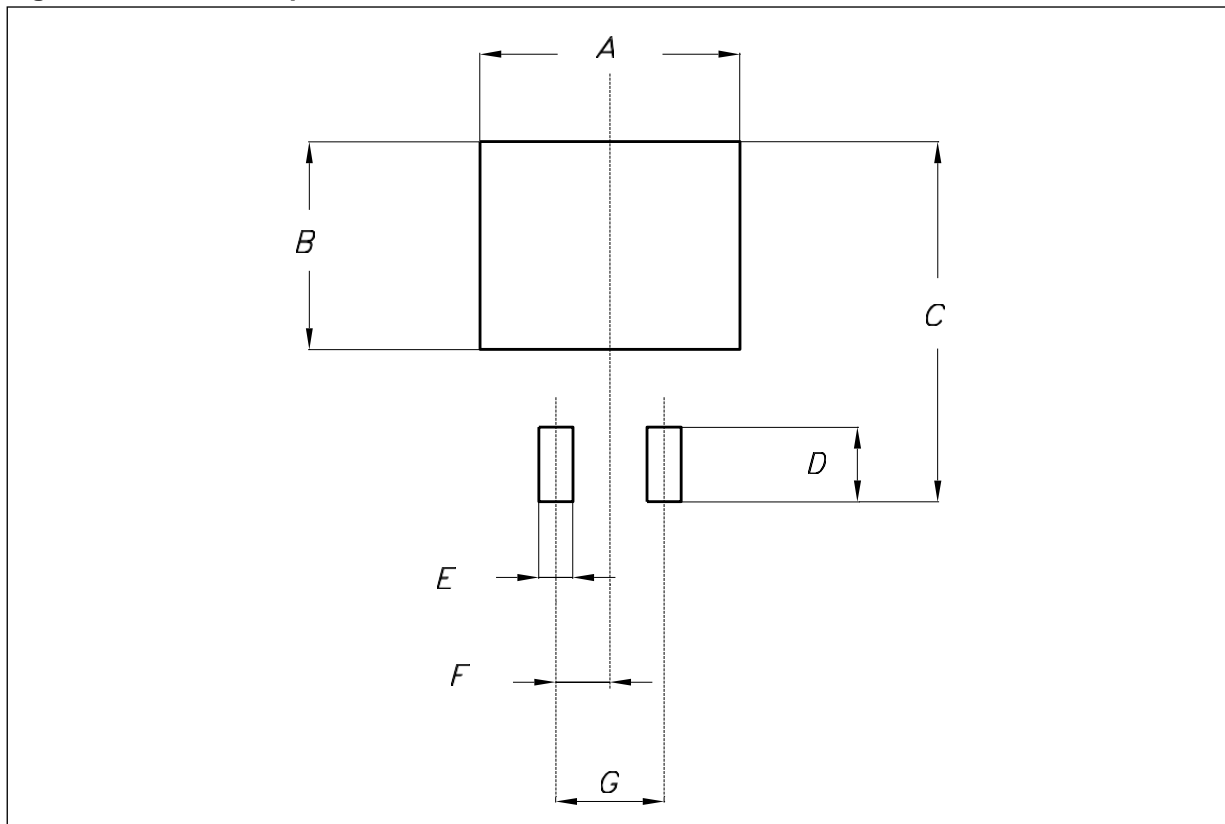

Table 29. D²PAK footprint data

Dim.	Values	
	mm.	inch.
A	12.20	0.480
B	9.75	0.384
C	16.90	0.665
D	3.50	0.138
E	1.60	0.063
F	2.54	0.100
G	5.08	0.200

Table 30. Tape and reel D²PAK mechanical data

Dim.	mm.			inch.		
	Min.	Typ.	Max.	Min.	Typ.	Max.
A			180			7.086
C	12.8	13.0	13.2	0.504	0.512	0.519
D	20.2			0.795		
N	60			2.362		
T			14.4			0.567
Ao	10.50	10.6	10.70	0.413	0.417	0.421
Bo	15.70	15.80	15.90	0.618	0.622	0.626
Ko	4.80	4.90	5.00	0.189	0.193	0.197
Po	3.9	4.0	4.1	0.153	0.157	0.161
P	11.9	12.0	12.1	0.468	0.472	0.476

Figure 49. Drawing dimension tape and reel for D²PAK

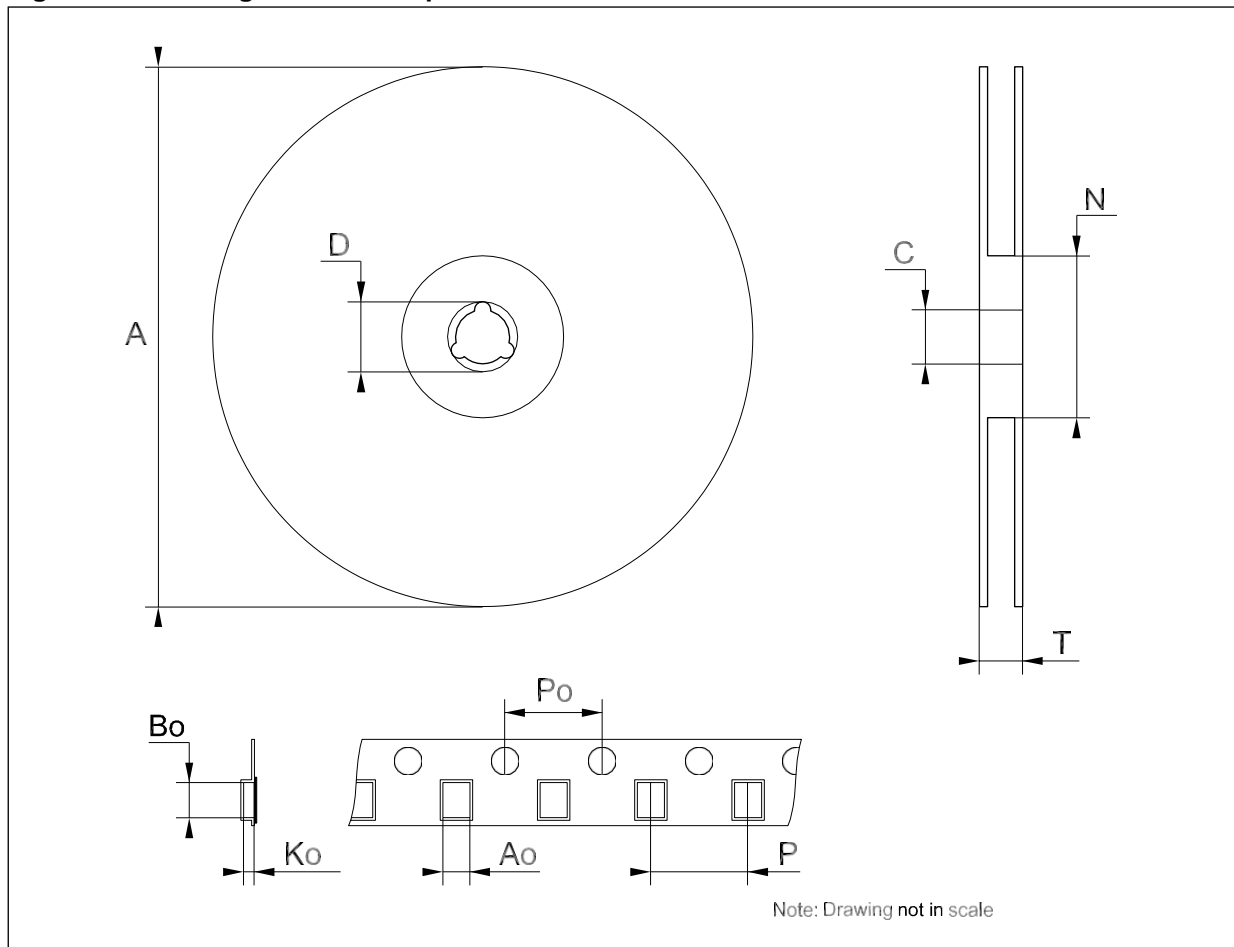

9 Order codes

Table 31. Order codes

Part numbers	Order codes					
	TO-220	DPAK	D ² PAK	TO-220FP	TO-3	Output voltages
L7805					L7805T	5 V
L7805C	L7805CV	L7805CDT-TR	L7805CD2T-TR	L7805CP	L7805CT	5 V
	L7805CV-DG ⁽¹⁾					5 V
L7805AB	L7805ABV		L7805ABD2T-TR	L7805ABP		5 V
	L7805ABV-DG ⁽¹⁾					5 V
L7805AC	L7805ACV		L7805ACD2T-TR	L7805ACP		5 V
	L7805ACV-DG ⁽¹⁾					5 V
L7806C	L7806CV		L7806CD2T-TR		L7806CT	6 V
	L7806CV-DG ⁽¹⁾					6 V
L7806AB	L7806ABV		L7806ABD2T-TR			6 V
	L7806ABV-DG ⁽¹⁾					6 V
L7806AC	L7806ACV					6 V
	L7806ACV-DG ⁽¹⁾					6 V
L7808C	L7808CV		L7808CD2T-TR			8 V
	L7808CV-DG ⁽¹⁾					8 V
L7808AB	L7808ABV		L7808ABD2T-TR			8 V
	L7808ABV-DG ⁽¹⁾					8 V
L7808AC	L7808ACV					8 V
	L7808ACV-DG ⁽¹⁾					8 V
L7885C	L7885CV		L7885CD2T-TR ⁽²⁾	L7885CP ⁽²⁾	L7885CT ⁽²⁾	8.5 V
L7809C	L7809CV		L7809CD2T-TR	L7809CP		9 V
	L7809CV-DG ⁽¹⁾					9 V
L7809AB	L7809ABV		L7809ABD2T-TR			9 V
L7809AC	L7809ACV					9 V
L7812C	L7812CV		L7812CD2T-TR	L7812CP	L7812CT	12 V
	L7812CV-DG ⁽¹⁾					12 V
L7812AB	L7812ABV		L7812ABD2T-TR			12 V
	L7812ABV-DG ⁽¹⁾					12 V
L7812AC	L7812ACV		L7812ACD2T-TR			12 V
	L7812ACV-DG ⁽¹⁾					12 V

Table 31. Order codes

Part numbers	Order codes					
	TO-220	DPAK	D ² PAK	TO-220FP	TO-3	Output voltages
L7815C	L7815CV		L7815CD2T-TR	L7815CP	L7815CT	15 V
	L7815CV-DG ⁽¹⁾					15 V
L7815AB	L7815ABV		L7815ABD2T-TR			15 V
	L7815ABV-DG ⁽¹⁾					15 V
L7815AC	L7815ACV		L7815ACD2T-TR			15 V
	L7815ACV-DG ⁽¹⁾					15 V
L7818C	L7818CV		L7818CD2T-TR ⁽²⁾		L7818CT	18 V
	L7818CV-DG ⁽¹⁾					18 V
L7824C	L7824CV		L7824CD2T-TR	L7824CP	L7824CT	24 V
	L7824CV-DG ⁽¹⁾					24 V
L7824AB	L7824ABV					24 V
	L7824ABV-DG ⁽¹⁾					24 V
L7824AC	L7824ACV					24 V
	L7824ACV-DG ⁽¹⁾					24 V

1. TO-220 Dual Gauge frame.

2. Available on request.

10 Revision history

Table 32. Document revision history

Date	Revision	Changes
21-Jun-2004	12	Document updating.
03-Aug-2006	13	Order codes has been updated and new template.
19-Jan-2007	14	D ² PAK mechanical data has been updated and add footprint data.
31-May-2007	15	Order codes has been updated.
29-Aug-2007	16	Added Table 1 in cover page.
11-Dec-2007	17	Modified: Table 31 .
06-Feb-2008	18	Added: TO-220 mechanical data Figure 38 on page 40 , Figure 39 on page 41 , and Table 23 on page 39 . Modified: Table 31 on page 54 .
18-Mar-2008	19	Added: Table 26: DPAK mechanical data on page 47 , Table 27: Tape and reel DPAK mechanical data on page 48 . Modified: Table 31 on page 54 .
26-Jan-2010	20	Modified Table 1 on page 1 and Table 23 on page 39 , added: Figure 38 on page 40 and Figure 39 on page 41 , Figure 40 on page 42 and Figure 41 on page 42 .
04-Mar-2010	21	Added notes Figure 38 on page 40 .
08-Sep-2010	22	Modified Table 31 on page 54 .
23-Nov-2010	23	Added: T _J = 25 °C test condition in ΔV _O on Table 5 , 6 , 7 , 8 , 9 , 10 and Table 11 .
16-Sep-2011	24	Modified title on page 1.
30-Nov-2011	25	Added: order codes L7805CV-DG, L7806CV-DG, L7808ABV-DG, L7812CV-DG and L7815CV-DG Table 31 on page 54 .
08-Feb-2012	26	Added: order codes L7805ACV-DG, L7805ABV-DG, L7806ABV-DG, L7808CV-DG, L7809CV-DG, L7812ACV-DG, L7818CV-DG, L7824CV-DG Table 31 on page 54 .
27-Mar-2012	27	Added: order codes L7812ABV-DG, L7815ABV-DG Table 31 on page 54 .
27-Apr-2012	28	Modified: V _I = 10.4 to 23 V ==> V _I = 11.4 to 23 V test conditon value Line regulation Table 8 on page 13 .
10-May-2012	29	Added: order codes L7806ACV-DG, L7808ACV-DG, L7815ACV-DG, L7824ABV-DG and L7824ACV-DG Table 31 on page 54 .

Please Read Carefully:

Information in this document is provided solely in connection with ST products. STMicroelectronics NV and its subsidiaries ("ST") reserve the right to make changes, corrections, modifications or improvements, to this document, and the products and services described herein at any time, without notice.

All ST products are sold pursuant to ST's terms and conditions of sale.

Purchasers are solely responsible for the choice, selection and use of the ST products and services described herein, and ST assumes no liability whatsoever relating to the choice, selection or use of the ST products and services described herein.

No license, express or implied, by estoppel or otherwise, to any intellectual property rights is granted under this document. If any part of this document refers to any third party products or services it shall not be deemed a license grant by ST for the use of such third party products or services, or any intellectual property contained therein or considered as a warranty covering the use in any manner whatsoever of such third party products or services or any intellectual property contained therein.

UNLESS OTHERWISE SET FORTH IN ST'S TERMS AND CONDITIONS OF SALE ST DISCLAIMS ANY EXPRESS OR IMPLIED WARRANTY WITH RESPECT TO THE USE AND/OR SALE OF ST PRODUCTS INCLUDING WITHOUT LIMITATION IMPLIED WARRANTIES OF MERCHANTABILITY, FITNESS FOR A PARTICULAR PURPOSE (AND THEIR EQUIVALENTS UNDER THE LAWS OF ANY JURISDICTION), OR INFRINGEMENT OF ANY PATENT, COPYRIGHT OR OTHER INTELLECTUAL PROPERTY RIGHT.

UNLESS EXPRESSLY APPROVED IN WRITING BY TWO AUTHORIZED ST REPRESENTATIVES, ST PRODUCTS ARE NOT RECOMMENDED, AUTHORIZED OR WARRANTED FOR USE IN MILITARY, AIR CRAFT, SPACE, LIFE SAVING, OR LIFE SUSTAINING APPLICATIONS, NOR IN PRODUCTS OR SYSTEMS WHERE FAILURE OR MALFUNCTION MAY RESULT IN PERSONAL INJURY, DEATH, OR SEVERE PROPERTY OR ENVIRONMENTAL DAMAGE. ST PRODUCTS WHICH ARE NOT SPECIFIED AS "AUTOMOTIVE GRADE" MAY ONLY BE USED IN AUTOMOTIVE APPLICATIONS AT USER'S OWN RISK.

Resale of ST products with provisions different from the statements and/or technical features set forth in this document shall immediately void any warranty granted by ST for the ST product or service described herein and shall not create or extend in any manner whatsoever, any liability of ST.

ST and the ST logo are trademarks or registered trademarks of ST in various countries.

Information in this document supersedes and replaces all information previously supplied.

The ST logo is a registered trademark of STMicroelectronics. All other names are the property of their respective owners.

© 2012 STMicroelectronics - All rights reserved

STMicroelectronics group of companies

Australia - Belgium - Brazil - Canada - China - Czech Republic - Finland - France - Germany - Hong Kong - India - Israel - Italy - Japan - Malaysia - Malta - Morocco - Philippines - Singapore - Spain - Sweden - Switzerland - United Kingdom - United States of America

www.st.com