



گروه فنی مهندسی جوش و برش مقدم

اعتماد از شما کیفیت و تخصص از ما



09153223758



051-37581400



<https://www.moghadamwelding>



<http://instagram.com/moghadam>



<https://t.me/moghadamwelding>



<https://whatsapp.com/channel>



<https://rubika.ir/moghadamwelding>



مشهد خیام شمالی 63 خیابان پردیس 3

برای کسب اطلاعات بیشتر بر روی لینک ها کلیک کنید

- 7 سال سابقه آموزش تعمیرات تخصصی دستگاه های جوش اینورتری تک فاز و 3 فاز
- 7 سال سابقه فروش قطعات الکترونیکی دستگاه جوش تک فاز و 3 فاز
- آموزش تخصصی تحلیل دستگاه های جوش اینورتری مختص ابراز فروشان
- آموزش تخصصی ابراز آلات شارژی

Diac



DO-35

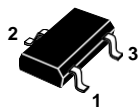

SOT-23

Pin 1 and 3 must be shorted together

Features

- V_{BO} : 32 V and 40 V
- Low breakover current
- Breakover voltage symmetry : 3V
- ECOPACK[®]2 compliant

Applications

- Triggering device for Triac or SCR based motor / light dimmer
- 32 V trigger device for oscillator circuit
- Start up triggering in lighting ballast for CFL, TL or LED lamps

Description

Functioning as a trigger diode with a fixed voltage reference, the DB3/DB4 series can be used in conjunction with triacs for simplified gate control circuits or as a starting element in fluorescent lamp ballasts.

The surface mount SOT23-3L package allows compact, SMD based designs for automated manufacturing.

Product status link

[DB3](#)
[DB4](#)
[SMDB3](#)

Product summary

Part number	V_{BO}
SMDB3	28 - 36 V
DB3	28 - 36 V
DB4	35 - 45 V

1 Characteristics

Table 1. Absolute maximum ratings (limiting values), $T_j = 25\text{ °C}$ unless otherwise specified

Symbol	Parameter		Value	Unit
I_{TRM}	Repetitive peak on-state current, $t_p = 20\ \mu\text{s}$, $F = 120\ \text{Hz}$	SMDB3	1.00	A
		DB3 / DB4	2.00	A
T_{stg}	Storage junction temperature range		-40 to +125	$^{\circ}\text{C}$
T_j	Operating junction temperature range		-40 to +125	$^{\circ}\text{C}$

Table 2. Electrical characteristics ($T_j = 25\text{ °C}$ unless otherwise specified)

Symbol	Parameter	Test conditions		SMDB3	DB3	DB4	Unit
V_{BO}	Breakover voltage ⁽¹⁾	$C = 10\ \text{nF}$ ⁽²⁾	Min.	28	28	35	V
			Typ.	32	32	40	
			Max.	36	36	45	
$ V_{BO1} - V_{BO2} $	Breakover voltage symmetry	$C = 10\ \text{nF}$ ⁽²⁾	Max.	3	3	3	V
ΔV	Dynamic breakover voltage ⁽¹⁾	V_{BO} and V_F at 10 mA	Min.	10	5	5	V
V_O	Output voltage ⁽¹⁾	See Figure 2. Test circuit, ($R = 20\ \Omega$)	Min.	10	5	5	V
I_{BO}	Breakover current ⁽¹⁾	$C = 10\ \text{nF}$ ⁽²⁾	Max.	10	50	50	μA
t_r	Rise time ⁽¹⁾	See Figure 3. Rise time measurement	Max.	0.5	2	2	μs
I_R	Leakage current ⁽¹⁾	$V_R = 0.5 \times V_{BO\ \text{max}}$	Max.	1	10	10	μA
I_P	Peak current ⁽¹⁾	See Figure 2. Test circuit	Min.	1	0.30	0.30	A

1. Applicable to both forward and reverse directions.

2. Connected in parallel to the device

Figure 1. Voltage - current characteristic curve.

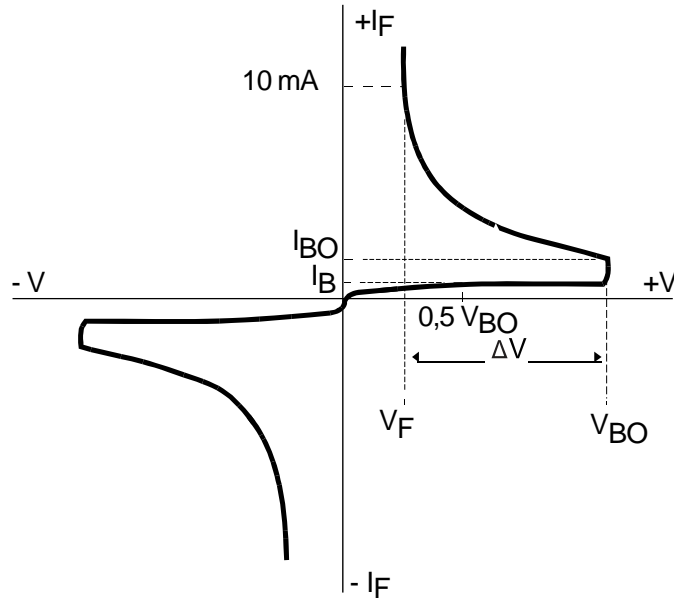

Figure 2. Test circuit

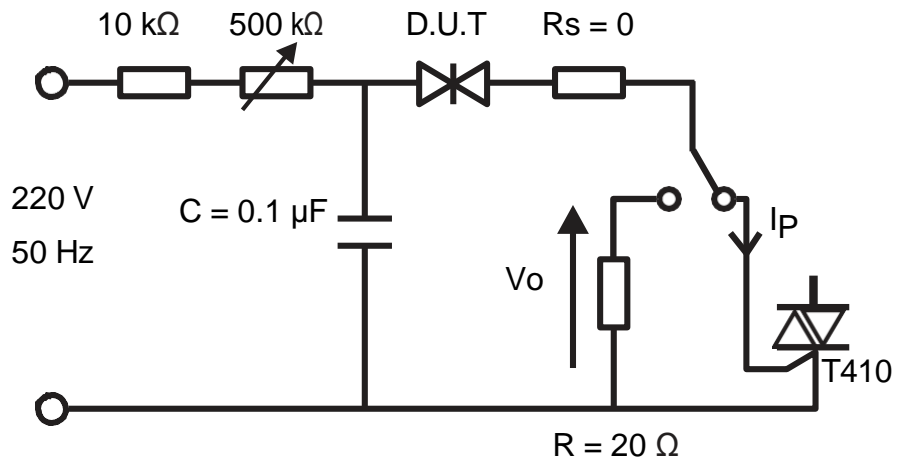
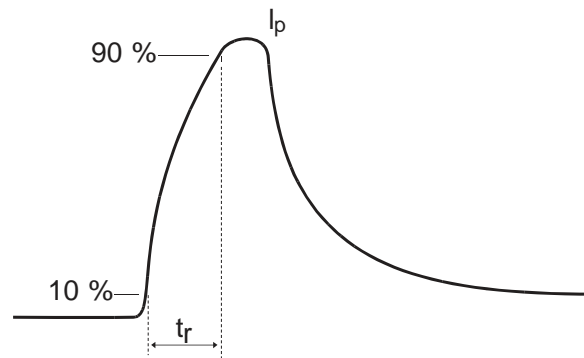

Figure 3. Rise time measurement



1.1 Characteristics curves

Figure 4. Relative variation of VBO versus junction temperature (typical values)

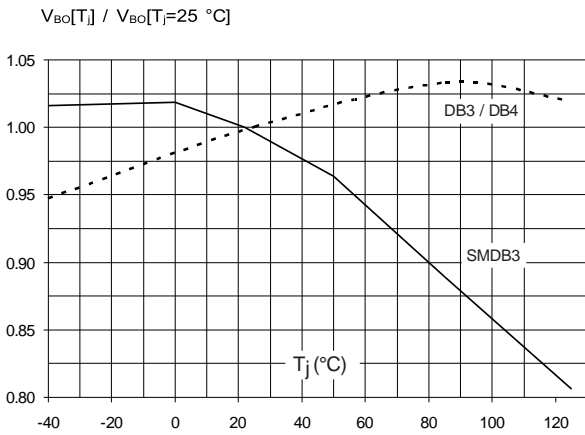

Figure 5. On-state RMS current versus Triac gate current pulse duration t_p

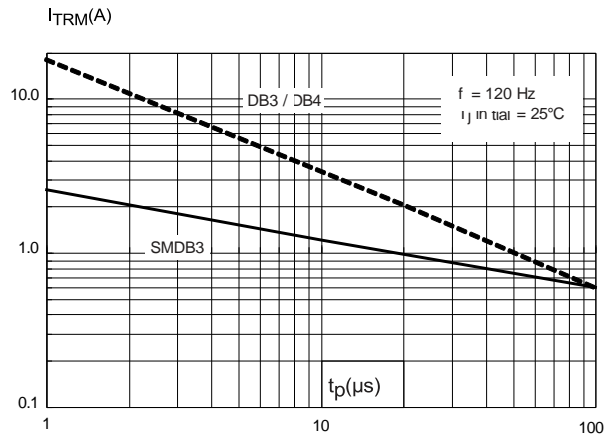
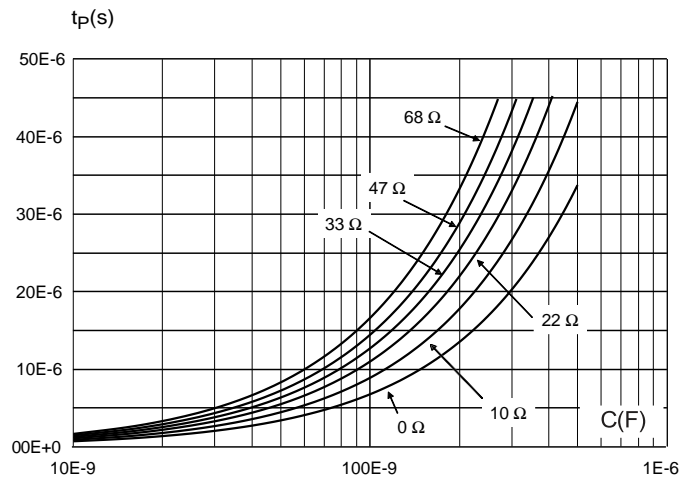

Figure 6. Triac gate current pulse duration t_p (to have $I_p > 50 \text{ mA}$) versus R_s and C values (typical values)



Note: according to Figure 2. Test circuit

2 Package information

In order to meet environmental requirements, ST offers these devices in different grades of **ECOPACK®** packages, depending on their level of environmental compliance. ECOPACK® specifications, grade definitions and product status are available at: www.st.com. ECOPACK® is an ST trademark.

2.1 SOT23 package information

Figure 7. SOT23-3L package outline

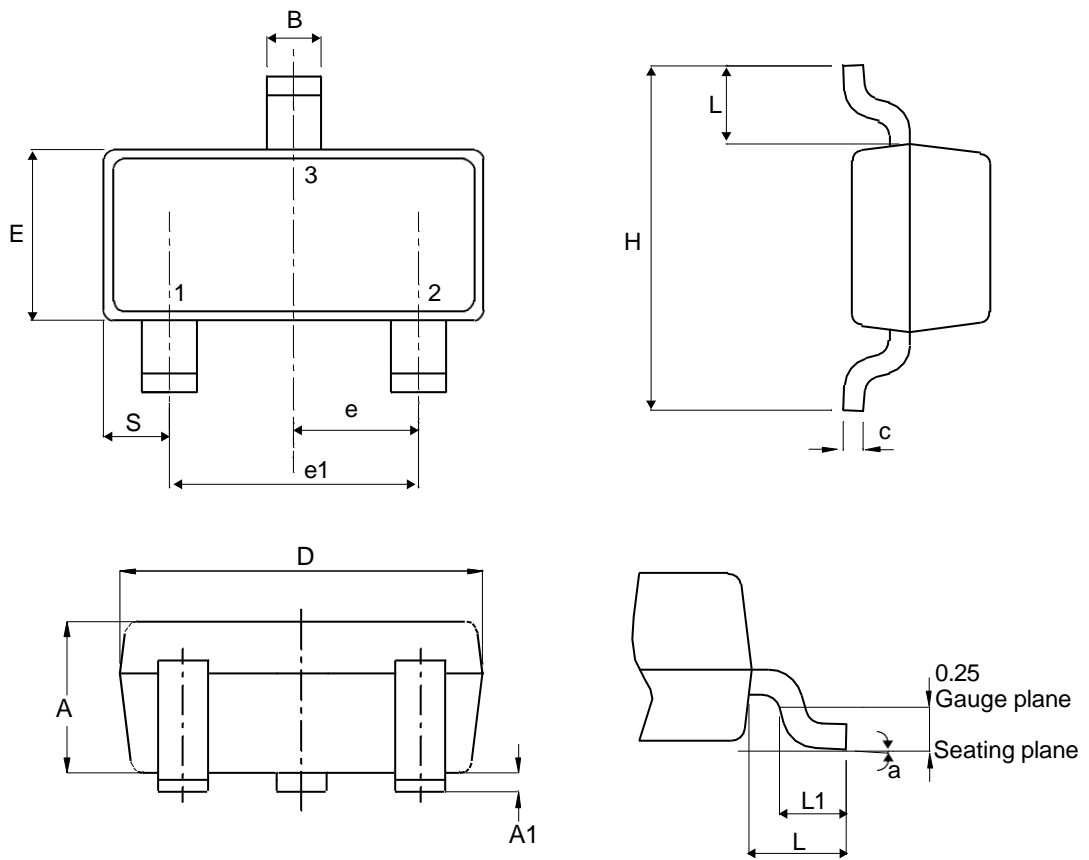
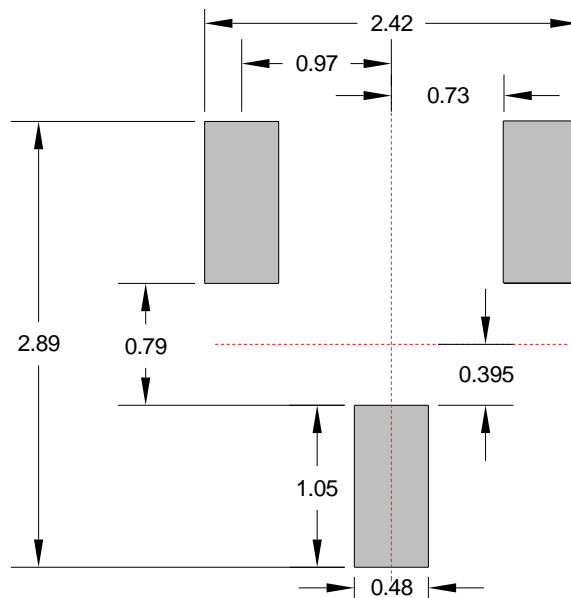

Table 3. SOT23-3L package mechanical data

Ref.	Dimensions					
	Millimeters			Inches (for reference only)		
	Min.	Typ.	Max.	Min.	Typ.	Max.
A	0.89		1.40	0.0350		0.0551
A1	0.00		0.10	0.0000		0.0039
B	0.30		0.51	0.0118		0.0201
C	0.085		0.18	0.0033		0.0071
D	2.75		3.04	0.1083		0.1197
e	0.85		1.05	0.0335		0.0413
e1	1.70		2.10	0.0669		0.0827
E	1.20		1.75	0.0472		0.0689
H	2.10		3.00	0.0827		0.1181
L		0.60			0.0236	
S	0.35		0.65	0.0138		0.256
L1	0.25		0.55	0.0098		0.0217
a	0°		8°	0°		8°

Figure 8. SOT23-3L footprint in mm

2.2 DO-35 package information

Figure 9. DO-35 package outline

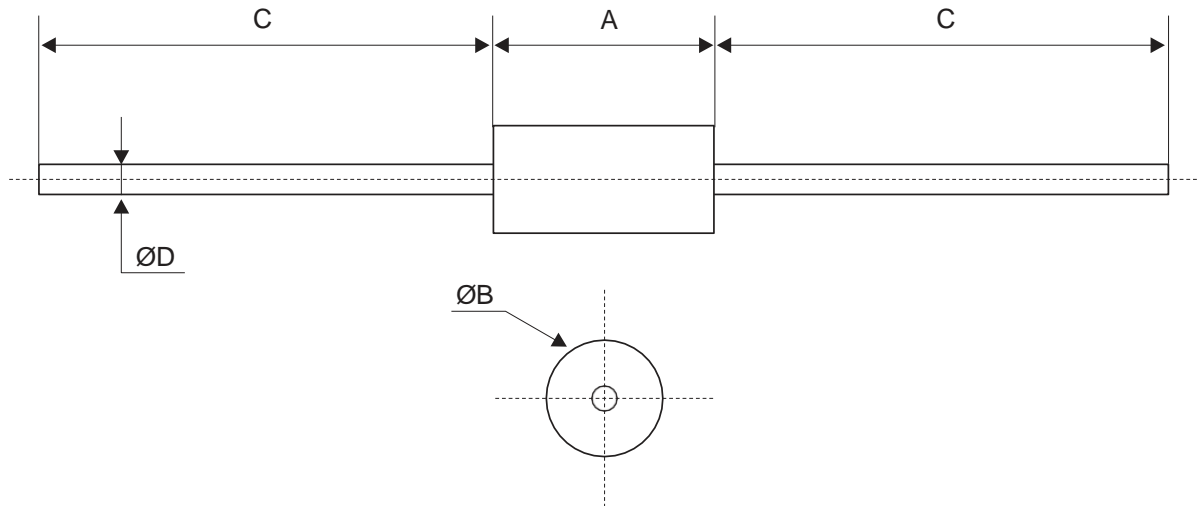

Table 4. DO-35 package mechanical data

Ref.	Dimensions			
	Millimeters		Inches (for reference only)	
	Min.	Max.	Min.	Max.
A	3.05	4.50	0.120	0.177
B	1.53	2.00	0.060	0.079
C	28.00	31.00	1.102	1.220
D	0.46	0.55	0.018	0.022

3 Ordering information

Figure 10. Ordering information scheme

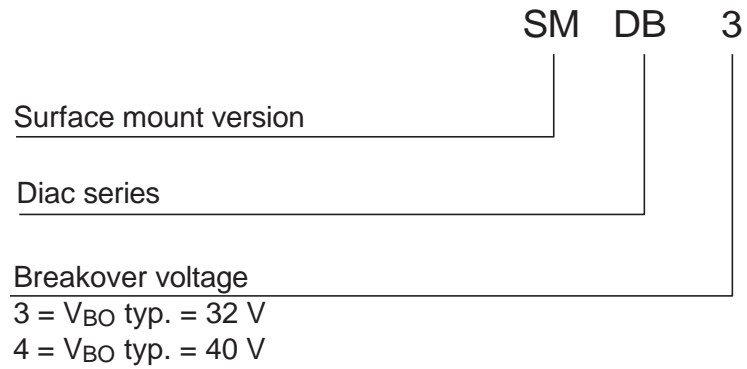

Table 5. Ordering information

Order code	Marking	Package	Weight	Base qty.	Delivery mode
SMDB3	DB3	SOT-23	0.01 g	3000	Tape and reel
DB3	DB3 (Blue Body Coat)	DO-35	0.15 g	5000	Tape and reel
DB4	DB4 (Blue Body Coat)		0.15 g	5000	Tape and reel

Revision history

Table 6. Document revision history

Date	Version	Changes
18-Jun-2018	2	First release.
14-Dec-2018	3	Minor text change to improve readability.

IMPORTANT NOTICE – PLEASE READ CAREFULLY

STMicroelectronics NV and its subsidiaries (“ST”) reserve the right to make changes, corrections, enhancements, modifications, and improvements to ST products and/or to this document at any time without notice. Purchasers should obtain the latest relevant information on ST products before placing orders. ST products are sold pursuant to ST’s terms and conditions of sale in place at the time of order acknowledgement.

Purchasers are solely responsible for the choice, selection, and use of ST products and ST assumes no liability for application assistance or the design of Purchasers’ products.

No license, express or implied, to any intellectual property right is granted by ST herein.

Resale of ST products with provisions different from the information set forth herein shall void any warranty granted by ST for such product.

ST and the ST logo are trademarks of ST. All other product or service names are the property of their respective owners.

Information in this document supersedes and replaces information previously supplied in any prior versions of this document.

© 2018 STMicroelectronics – All rights reserved