



# گروه فنی مهندسی جوش و برش مقدم

اعتماد از شما کیفیت و تخصص از ما



09153223758



051-37581400



<https://www.moghadamwelding>



<http://instagram.com/moghadam>



<https://t.me/moghadamwelding>



<https://whatsapp.com/channel>



<https://rubika.ir/moghadamwelding>



مشهد خیام شمالی 63 خیابان پردیس 3

برای کسب اطلاعات بیشتر بر روی لینک ها کلیک کنید

- 7 سال سابقه آموزش تعمیرات تخصصی دستگاه های جوش اینورتری تک فاز و 3 فاز
- 7 سال سابقه فروش قطعات الکترونیکی دستگاه جوش تک فاز و 3 فاز
- آموزش تخصصی تحلیل دستگاه های جوش اینورتری مختص ابراز فروشان
- آموزش تخصصی ابراز آلات شارژی

# High voltage fast-switching NPN power transistor

## Features

- Low spread of dynamic parameters
- High voltage capability
- Minimum lot-to-lot spread for reliable operation
- Very high switching speed

## Applications

- Switch mode power supplies

## Description

The device is manufactured using high voltage multi-epitaxial planar technology for high switching speeds and high voltage capability. It uses a hollow emitter structure to enhance switching speeds.

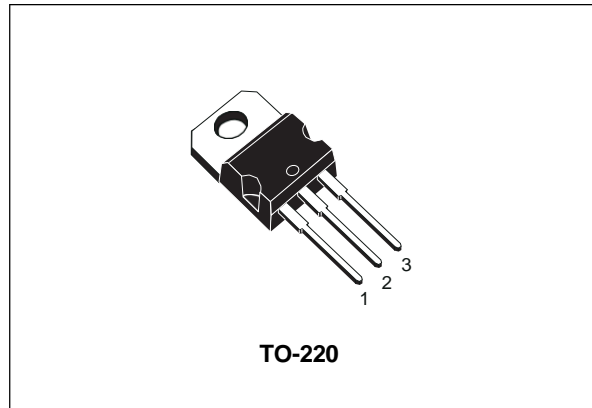

**Figure 1. Internal schematic diagram**

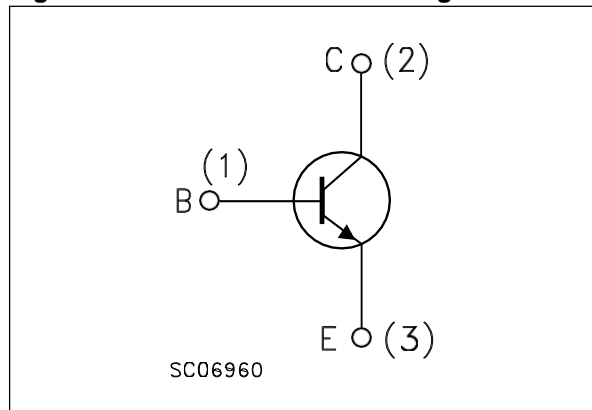

**Table 1. Device summary**

Order code	Marking <sup>(1)</sup>	Package	Packaging
ST13009	13009 L 13009 H	TO-220	Tube

1. Product is pre-selected in DC current gain (group L and group H). STMicroelectronics reserves the right to ship either groups according to production availability. Please contact your nearest STMicroelectronics sales office for delivery details.

---

## Contents

<b>1</b>	<b>Electrical ratings .....</b>	<b>3</b>
<b>2</b>	<b>Electrical characteristics .....</b>	<b>4</b>
	2.1 Electrical characteristics (curves).....	5
<b>3</b>	<b>Test circuit .....</b>	<b>7</b>
<b>4</b>	<b>Package mechanical data .....</b>	<b>8</b>
<b>5</b>	<b>Revision history .....</b>	<b>10</b>

# 1 Electrical ratings

**Table 2. Absolute maximum ratings**

Symbol	Parameter	Value	Unit
$V_{CEV}$	Collector-emitter voltage ( $V_{BE} = -1.5\text{ V}$ )	700	V
$V_{CEO}$	Collector-emitter voltage ( $I_B = 0$ )	400	V
$V_{EBO}$	Emitter-base voltage ( $I_C = 0$ )	12	V
$I_C$	Collector current	12	A
$I_{CM}$	Collector peak current ( $t_P < 5\text{ms}$ )	24	A
$I_B$	Base current	6	A
$I_{BM}$	Base peak current ( $t_P < 5\text{ms}$ )	12	A
$P_{tot}$	Total dissipation at $T_C = 25^\circ\text{C}$	100	W
$T_{stg}$	Storage temperature	-65 to 150	$^\circ\text{C}$
$T_J$	Max. operating junction temperature	150	$^\circ\text{C}$

**Table 3. Thermal data**

Symbol	Parameter	Value	Unit
$R_{thj-case}$	Thermal resistance junction-case	Max 1.25	$^\circ\text{C/W}$

## 2 Electrical characteristics

( $T_{case} = 25^{\circ}C$  unless otherwise specified)

**Table 4. Electrical characteristics**

Symbol	Parameter	Test conditions	Min.	Typ.	Max.	Unit
$I_{CEV}$	Collector cut-off current ( $V_{BE} = -1.5 V$ )	$V_{CE} = 700 V$ $V_{CE} = 700 V \quad T_C = 100^{\circ}C$			10 500	$\mu A$ $\mu A$
$I_{EBO}$	Emitter cut-off current ( $I_C = 0$ )	$V_{EB} = 10 V$			10	$\mu A$
$V_{CEO(sus)}^{(1)}$	Collector-emitter sustaining voltage ( $I_B = 0$ )	$I_C = 10 mA$	400			V
$V_{CE(sat)}^{(1)}$	Collector-emitter saturation voltage	$I_C = 4 A \quad I_B = 0.8 A$ $I_C = 5 A \quad I_B = 1 A$ $I_C = 8 A \quad I_B = 1.6 A$ $I_C = 12 A \quad I_B = 3 A$			0.85 0.9 1.25 2.5	V V V V
$V_{BE(sat)}^{(1)}$	Base-emitter saturation voltage	$I_C = 5 A \quad I_B = 1 A$ $I_C = 8 A \quad I_B = 1.6 A$			1.2 1.6	V V
$h_{FE}^{(1)(2)}$	DC current gain	$I_C = 5 A \quad V_{CE} = 5 V$ Group L Group H $I_C = 8 A \quad V_{CE} = 5 V$	15 26 10		31 39 30	
$t_s$ $t_f$	Inductive load Storage time Fall time	$I_C = 5 A \quad V_{CC} = 250 V$ $I_{B1} = 1 A \quad I_{B2} = -2 A$ $L = 200 \mu H$ see <a href="#">Figure 9</a>		1.6 60	2.5 110	$\mu s$ ns
$t_s$ $t_f$	Inductive load Storage time Fall time	$I_C = 5 A \quad V_{CC} = 125 V$ $I_{B1} = - I_{B2} = 1.6 A$ $L = 200 \mu H \quad t_c = 125^{\circ}C$ see <a href="#">Figure 9</a>		2.3 110		$\mu s$ ns

1. Pulsed duration = 300  $\mu s$ , duty cycle  $\leq 2\%$
2. Product is pre-selected in DC current gain (group L and group H). STMicroelectronics reserves the right to ship either groups according to production availability. Please contact your nearest STMicroelectronics sales office for delivery details.

## 2.1 Electrical characteristics (curves)

Figure 2. Safe operating area

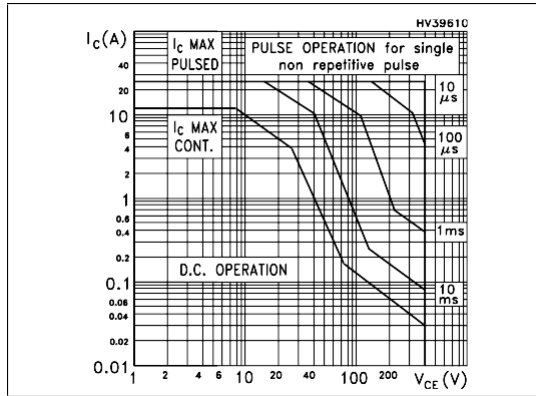

Figure 3. Derating curve

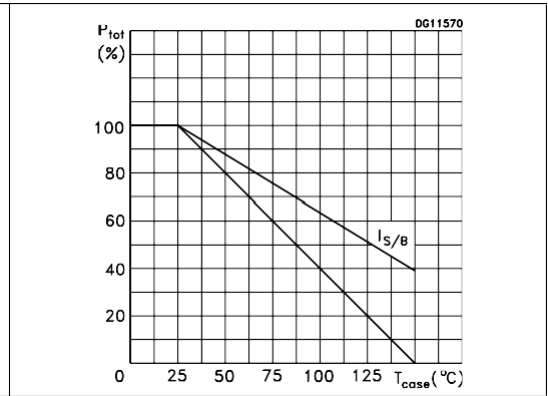

Figure 4. DC current gain

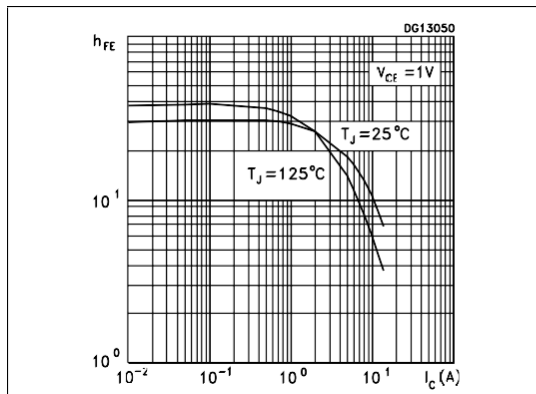

Figure 5. DC current gain

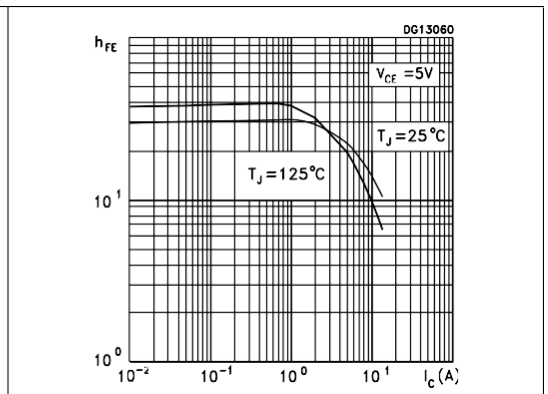

Figure 6. Collector-emitter saturation voltage

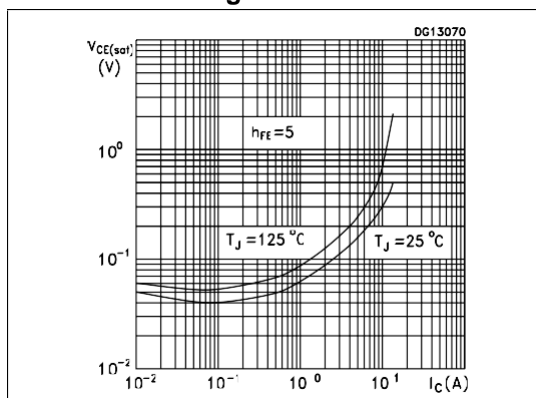

Figure 7. Base-emitter saturation voltage

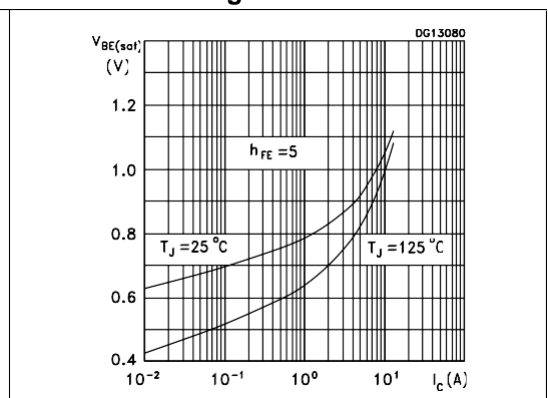
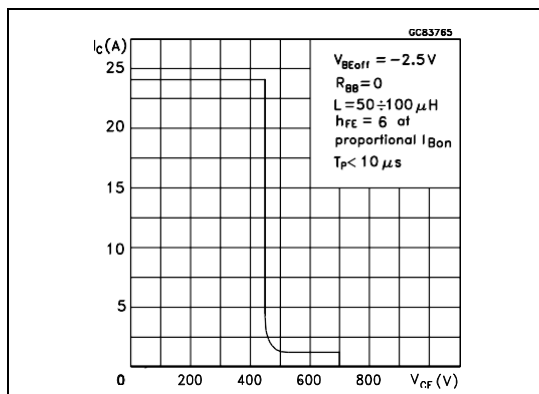
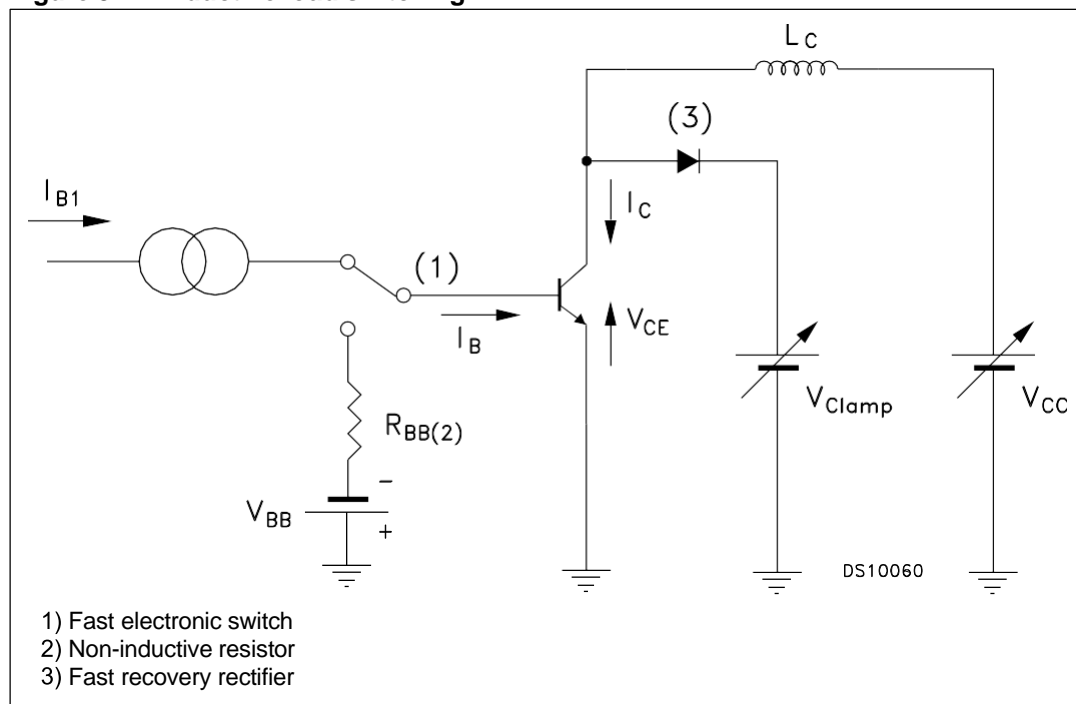

Figure 8. Reverse biased operating area



### 3 Test circuit

Figure 9. Inductive load switching





## 4 Package mechanical data

In order to meet environmental requirements, ST offers these devices in different grades of ECOPACK® packages, depending on their level of environmental compliance. ECOPACK® specifications, grade definitions and product status are available at: [www.st.com](http://www.st.com). ECOPACK is an ST trademark.

TO-220 mechanical data

Dim	mm			inch		
	Min	Typ	Max	Min	Typ	Max
A	4.40		4.60	0.173		0.181
b	0.61		0.88	0.024		0.034
b1	1.14		1.70	0.044		0.066
c	0.48		0.70	0.019		0.027
D	15.25		15.75	0.6		0.62
D1		1.27			0.050	
E	10		10.40	0.393		0.409
e	2.40		2.70	0.094		0.106
e1	4.95		5.15	0.194		0.202
F	1.23		1.32	0.048		0.051
H1	6.20		6.60	0.244		0.256
J1	2.40		2.72	0.094		0.107
L	13		14	0.511		0.551
L1	3.50		3.93	0.137		0.154
L20		16.40			0.645	
L30		28.90			1.137	
∅P	3.75		3.85	0.147		0.151
Q	2.65		2.95	0.104		0.116

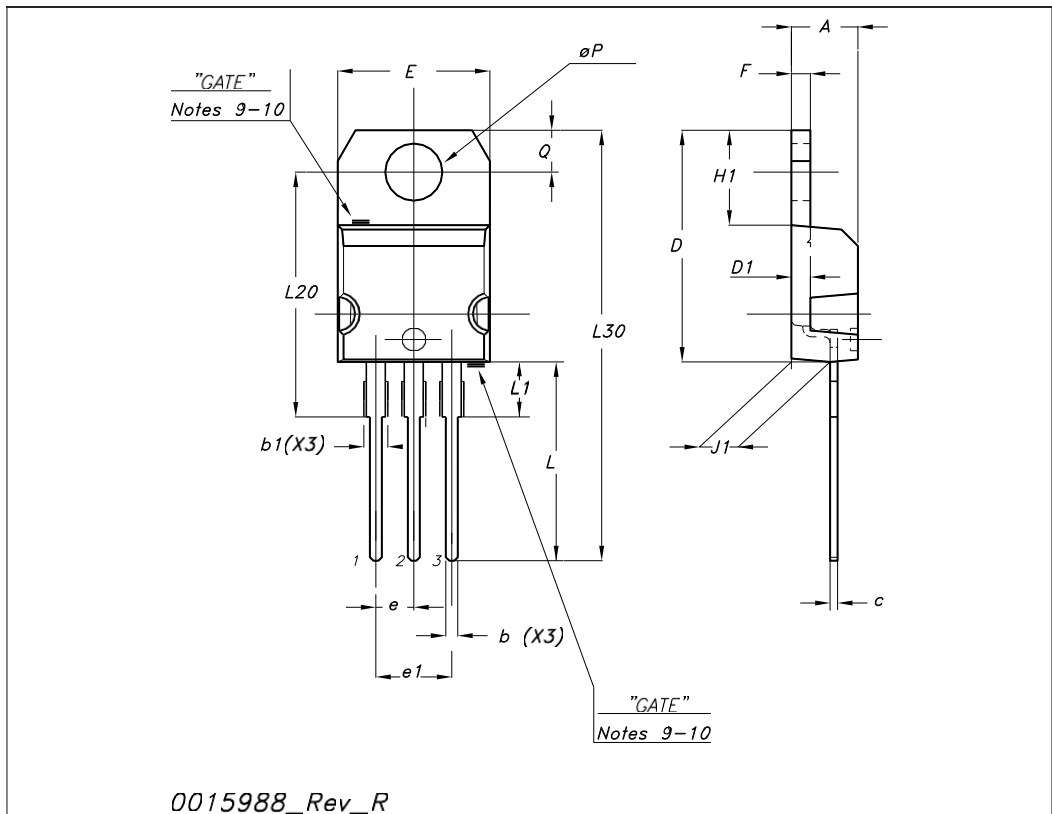

## 5 Revision history

**Table 5. Document revision history**

Date	Revision	Changes
12-Jun-2005	1	First version
23-Aug-2007	2	Added figures: <a href="#">2</a> , and <a href="#">3</a>
30-Jun-2009	3	Updated value for $h_{FE}$ see <a href="#">Table 4: Electrical characteristics</a>

**Please Read Carefully:**

Information in this document is provided solely in connection with ST products. STMicroelectronics NV and its subsidiaries ("ST") reserve the right to make changes, corrections, modifications or improvements, to this document, and the products and services described herein at any time, without notice.

All ST products are sold pursuant to ST's terms and conditions of sale.

Purchasers are solely responsible for the choice, selection and use of the ST products and services described herein, and ST assumes no liability whatsoever relating to the choice, selection or use of the ST products and services described herein.

No license, express or implied, by estoppel or otherwise, to any intellectual property rights is granted under this document. If any part of this document refers to any third party products or services it shall not be deemed a license grant by ST for the use of such third party products or services, or any intellectual property contained therein or considered as a warranty covering the use in any manner whatsoever of such third party products or services or any intellectual property contained therein.

**UNLESS OTHERWISE SET FORTH IN ST'S TERMS AND CONDITIONS OF SALE ST DISCLAIMS ANY EXPRESS OR IMPLIED WARRANTY WITH RESPECT TO THE USE AND/OR SALE OF ST PRODUCTS INCLUDING WITHOUT LIMITATION IMPLIED WARRANTIES OF MERCHANTABILITY, FITNESS FOR A PARTICULAR PURPOSE (AND THEIR EQUIVALENTS UNDER THE LAWS OF ANY JURISDICTION), OR INFRINGEMENT OF ANY PATENT, COPYRIGHT OR OTHER INTELLECTUAL PROPERTY RIGHT.**

**UNLESS EXPRESSLY APPROVED IN WRITING BY AN AUTHORIZED ST REPRESENTATIVE, ST PRODUCTS ARE NOT RECOMMENDED, AUTHORIZED OR WARRANTED FOR USE IN MILITARY, AIR CRAFT, SPACE, LIFE SAVING, OR LIFE SUSTAINING APPLICATIONS, NOR IN PRODUCTS OR SYSTEMS WHERE FAILURE OR MALFUNCTION MAY RESULT IN PERSONAL INJURY, DEATH, OR SEVERE PROPERTY OR ENVIRONMENTAL DAMAGE. ST PRODUCTS WHICH ARE NOT SPECIFIED AS "AUTOMOTIVE GRADE" MAY ONLY BE USED IN AUTOMOTIVE APPLICATIONS AT USER'S OWN RISK.**

Resale of ST products with provisions different from the statements and/or technical features set forth in this document shall immediately void any warranty granted by ST for the ST product or service described herein and shall not create or extend in any manner whatsoever, any liability of ST.

ST and the ST logo are trademarks or registered trademarks of ST in various countries.

Information in this document supersedes and replaces all information previously supplied.

The ST logo is a registered trademark of STMicroelectronics. All other names are the property of their respective owners.

© 2009 STMicroelectronics - All rights reserved

STMicroelectronics group of companies

Australia - Belgium - Brazil - Canada - China - Czech Republic - Finland - France - Germany - Hong Kong - India - Israel - Italy - Japan - Malaysia - Malta - Morocco - Philippines - Singapore - Spain - Sweden - Switzerland - United Kingdom - United States of America

[www.st.com](http://www.st.com)

