



گروه فنی مهندسی جوش و برش مقدم

اعتماد از شما کیفیت و تخصص از ما



09153223758



051-37581400



<https://www.moghadamwelding>



<http://instagram.com/moghadam>



<https://t.me/moghadamwelding>



<https://whatsapp.com/channel>



<https://rubika.ir/moghadamwelding>



مشهد خیام شمالی 63 خیابان پردیس 3

برای کسب اطلاعات بیشتر بر روی لینک ها کلیک کنید

- 7 سال سابقه آموزش تعمیرات تخصصی دستگاه های جوش اینورتری تک فاز و 3 فاز
- 7 سال سابقه فروش قطعات الکترونیکی دستگاه جوش تک فاز و 3 فاز
- آموزش تخصصی تحلیل دستگاه های جوش اینورتری مختص ابراز فروشان
- آموزش تخصصی ابراز آلات شارژی

Quad 2-input NAND Schmitt trigger

Datasheet - production data

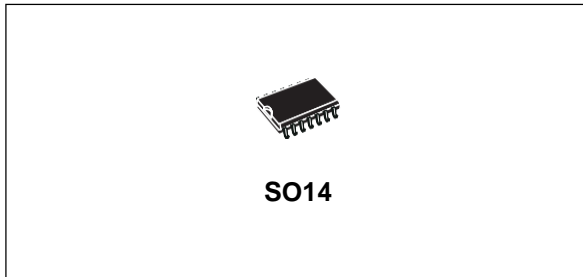

- ESD performance
 - HBM: 2 kV
 - MM: 200 V
 - CDM: 1 kV

Applications

- Automotive
- Industrial
- Computer
- Consumer

Features

- Schmitt trigger action on each input with no external components
- Hysteresis voltage typically 0.9 V at $V_{DD} = 5\text{ V}$ and 2.3 V at $V_{DD} = 10\text{ V}$
- Noise immunity greater than 50 % of V_{DD} (typ.)
- No limit on input rise and fall times
- Quiescent current specified up to 20 V
- Standardized symmetrical output characteristics
- 5 V, 10 V, and 15 V parametric ratings
- Input leakage current $I_I = 100\text{ nA}$ (max.) at $V_{DD} = 18\text{ V}$ and $T_A = 25\text{ }^\circ\text{C}$
- 100 % tested for quiescent current

Description

The HCF4093 is a monolithic integrated circuit fabricated in metal oxide semiconductor technology available in the SO14 package.

The HCF4093 consists of four Schmitt trigger circuits. Each circuit function has a 2-input NAND gate with Schmitt trigger action on both inputs. The gate switches at different points for positive and negative going signals. The difference between the positive voltage (V_P) and the negative voltage (V_N) is defined as hysteresis voltage (V_H).

Table 1. Device summary table

Order code	Temperature range	Package	Packing	Marking
HCF4093M013TR	-55 ° C to +125 ° C	SO14	Tape and reel	HCF4093
HCF4093YM013TR (1)	-40 ° C to +125 ° C	SO14 (automotive grade) ⁽¹⁾		HCF4093Y

1. Qualification and characterization according to AEC Q100 and Q003 or equivalent, advanced screening according to AEC Q001 & Q002 or equivalent.

Contents

1	Pin information	3
2	Functional description	4
3	Electrical characteristics.....	5
4	Package information.....	9
	4.1 SO14 package information.....	10
5	Ordering information	12
6	Revision history.....	12

1 Pin information

Figure 1. Pin connections (top view)

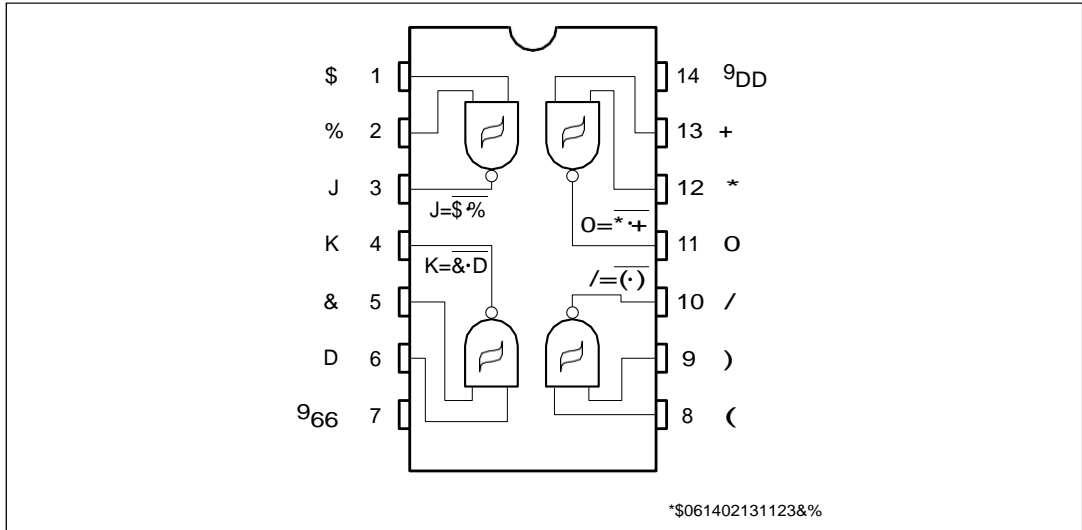

Table 2. Pin description

Pin no	Symbol	Name and function
1, 2, 5, 6, 8, 9, 12, 13	A, B, C, D, E, F, G, H	Data inputs
3, 4, 10, 11	J, K, L, M	Data outputs
7	V _{SS}	Negative supply voltage
14	V _{DD}	Positive supply voltage

2 Functional description

Table 3. Truth table

Inputs		Outputs
A, C, E, G	B, D, F, H	J, K, L, M
L	L	H
L	H	H
H	L	H
H	H	L

Figure 2. Input equivalent circuit

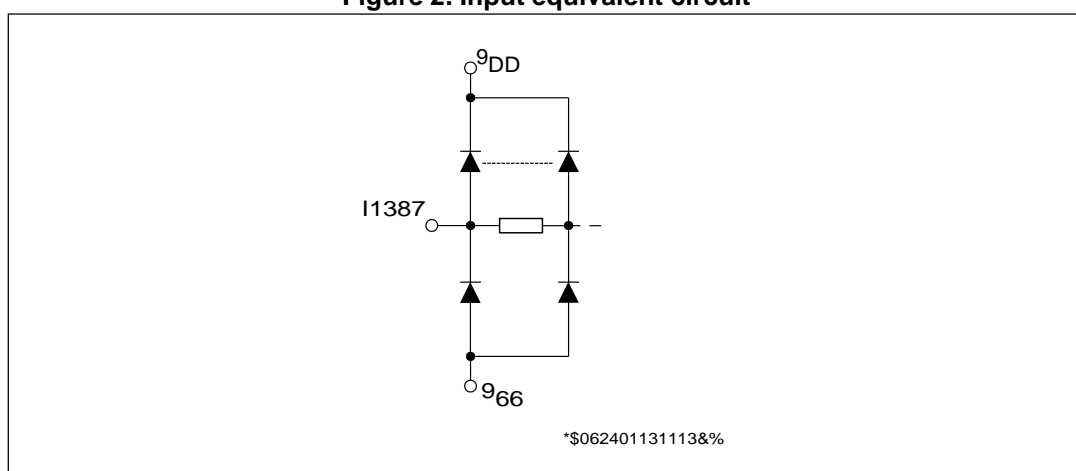

3 Electrical characteristics

Stressing the device above the ratings listed in the “Absolute maximum ratings” table may cause permanent damage to the device. These are stress ratings only and operation of the device at these or any other conditions above those indicated in the operating sections of this specification is not implied. Exposure to absolute maximum rating conditions for extended periods may affect device reliability. Refer also to the STMicroelectronics SURE Program and other relevant quality documents.

Table 4. Absolute maximum ratings (AMR)

Symbol	Parameter	Value	Unit
V_{DD}	Supply voltage	-0.5 to +22	V
V_I	DC input voltage	-0.5 to $V_{DD} + 0.5$	
I_I	DC input current	± 10	mA
P_D	Power dissipation per package	200	mW
	Power dissipation per output transistor	100	
T_{op}	Operating temperature	-55 to +125	°C
T_{stg}	Storage temperature	-65 to +150	

Table 5. Recommended operating conditions

Symbol	Parameter	Value	Unit
V_{DD}	Supply voltage	3 to 20	V
V_I	Input voltage	0 to V_{DD}	
T_{op}	Operating temperature	-55 to 125	°C

Table 6. DC specifications⁽¹⁾

Sym.	Parameter	Test condition				Value							Unit
		V _I (V)	V _O (V)	I _{ol} (μA)	V _{DD} (V)	T _A = 25 °C			-40 to 85 °C		-55 to 125 °C		
						Min.	Typ.	Max.	Min.	Max.	Min.	Max.	
I _L	Quiescent current	0/5			5			1		30		30	μA
		0/10			10		0.02	2		60		60	
		0/15			15			4		120		120	
		0/20			20		0.04	20		600		600	
V _{OH}	High level output voltage	0/5		<1	5	4.95			4.95		4.95		V
		0/10			10	9.95			9.95		9.95		
		0/15			15	14.95			14.95		14.95		
V _{OL}	Low level output voltage	5/0		<1	5							0.05	
		10/0			10		0.05			0.05			
		15/0			15								
V _P	Positive trigger threshold voltage	a			5	2.2	2.9	3.6	2.2	3.6	2.2	3.6	V
					10	4.6	5.9	7.1	4.6	7.1	4.6	7.1	
					15	6.8	8.8	10.8	6.8	10.8	6.8	10.8	
		b			5	2.6	3.3	4.0	2.6	4	2.6	4	
					10	5.6	7	8.2	5.6	8.2	5.6	8.2	
					15	6.3	9.4	12.7	6.3	12.7	6.3	12.7	
V _N	Negative trigger threshold voltage	a			5	0.9	1.9	2.8	0.9	2.8	0.9	2.8	V
					10	2.5	3.9	5.2	2.5	5.2	2.5	5.2	
					15	4	5.8	7.4	4	7.4	4	7.4	
		b			5	1.4	2.3	3.2	1.4	3.2	1.4	3.2	
					10	3.4	5.1	6.6	3.4	6.6	3.4	6.6	
					15	4.8	7.3	9.6	4.8	9.6	4.8	9.6	
V _H	Hysteresis voltage	a			5	0.3	0.9	1.6	0.3	1.6	0.3	1.6	V
					10	1.2	2.3	3.4	1.2	3.4	1.2	3.4	
					15	1.6	3.5	5	1.6	5	1.6	5	
		b			5	0.3	0.9	1.6	0.3	1.6	0.3	1.6	
					10	1.2	2.3	3.4	1.2	3.4	1.2	3.4	
					15	1.6	3.5	5	1.6	5	1.6	5	
I _{OH}	Output drive current	0/5	2.5	<1	5	-1.36	-3.2		-1.15		-1.1		mA
			4.6			-0.44	-1		-0.36		-0.36		
		0/10	9.5		10	-1.1	-2.6		-0.9		-0.9		
		0/15	13.5		15	-3.0	-6.8		-2.4		-2.4		

Table 6. DC specifications⁽¹⁾ (continued)

Sym.	Parameter	Test condition				Value						Unit	
		V _I (V)	V _O (V)	I _{ol} (μA)	V _{DD} (V)	T _A = 25 °C			-40 to 85 °C		-55 to 125 °C		
						Min.	Typ.	Max.	Min.	Max.	Min.		Max.
I _{OL}	Output sink current	0/5	0.4	<1	5	0.44	1		0.36		0.36		mA
		0/10	0.5		10	1.1	2.6		0.9		0.9		
		0/15	1.5		15	3.0	6.8		2.4		2.4		
I _I	Input leakage current	0/18	Any input		18		±10 ⁻⁵	±0.1		±1		±1	μA
C _I	Input capacitance		Any input				5	7.5					pF

1. The noise margin for both level "1" and "0" is: 1 V min. with V_{DD} = 5 V, 2 V min. with V_{DD} = 10 V, and 2.5 V min. with V_{DD} = 15 V.

a: Input on terminals 1, 5, 8, 12 or 2, 6, 9, 13; other inputs to V_{DD}.

b: Input on terminals 1 and 2, 5 and 6, 8 and 9, or 12 and 13; other inputs to V_{DD}.

Table 7. Dynamic electrical characteristics
(T_{amb} = 25 °C, C_L = 50 pF, R_L = 200 kΩ, t_r = t_f = 20 ns)

Symbol	Parameter	Test condition	Value ⁽¹⁾		Unit
		V _{DD} (V)	Typ.	Max.	
t _{PLH} , t _{PHL}	Propagation delay time	5	190	380	ns
		10	90	180	
		15	65	130	
t _{TLH} , t _{THL}	Output transition time	5	100	200	
		10	50	100	
		15	40	80	

1. The typical temperature coefficient for all V_{DD} values is 0.3 %/°C.

Figure 3. Test circuit

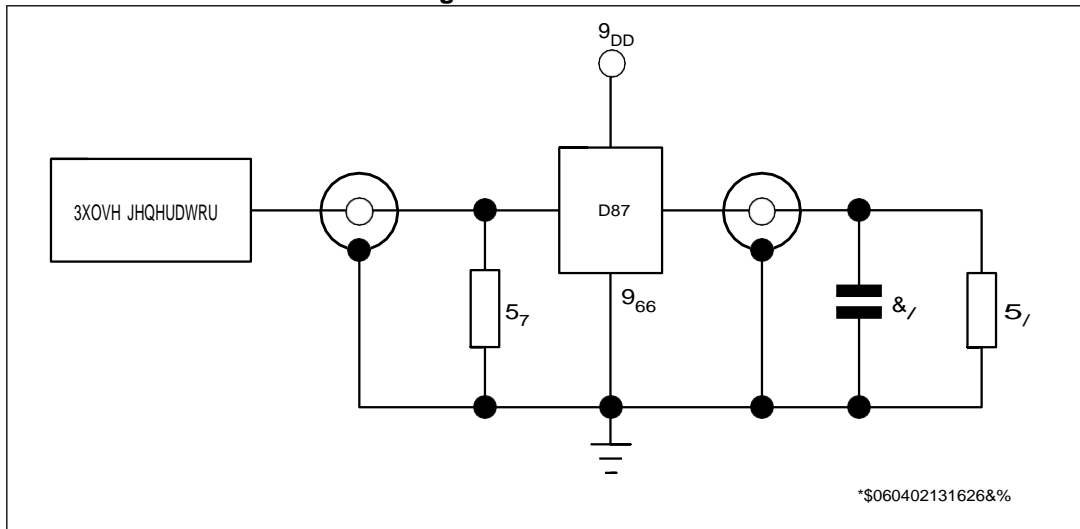

1. Legend: $C_L = 50 \text{ pF}$ or equivalent (includes jig and probe capacitance), $R_L = 200 \text{ K}\Omega$, $R_T = Z_{OUT}$ of pulse generator (typically 50Ω)

Figure 4. Propagation delay time waveform ($f = 1 \text{ MHz}$; 50 % duty cycle)

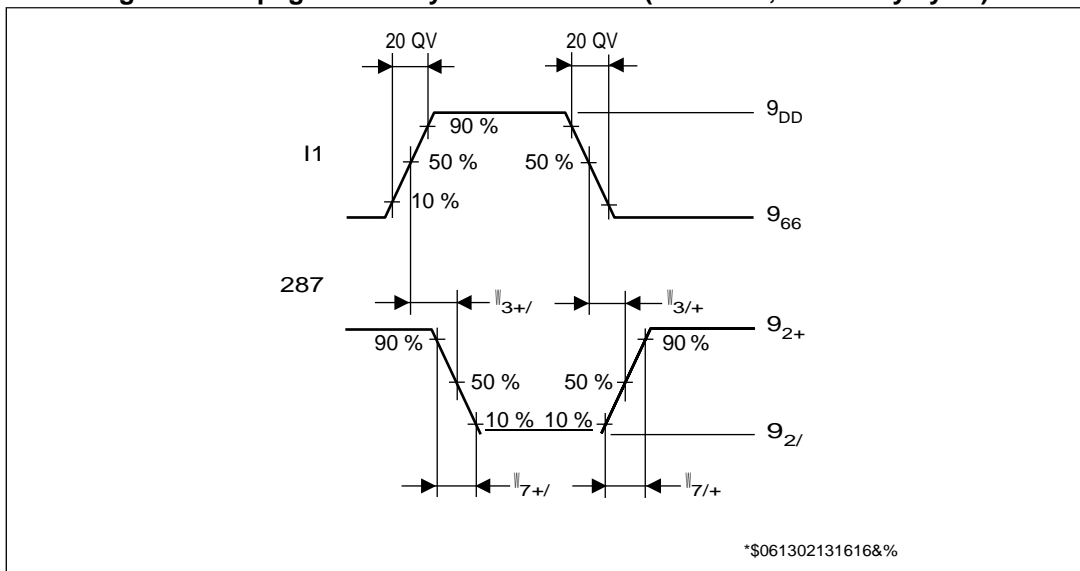

4 Package information

In order to meet environmental requirements, ST offers these devices in different grades of ECOPACK[®] packages, depending on their level of environmental compliance. ECOPACK[®] specifications, grade definitions and product status are available at: www.st.com. ECOPACK[®] is an ST trademark.

4.1 SO14 package information

Figure 5. SO14 package mechanical drawing

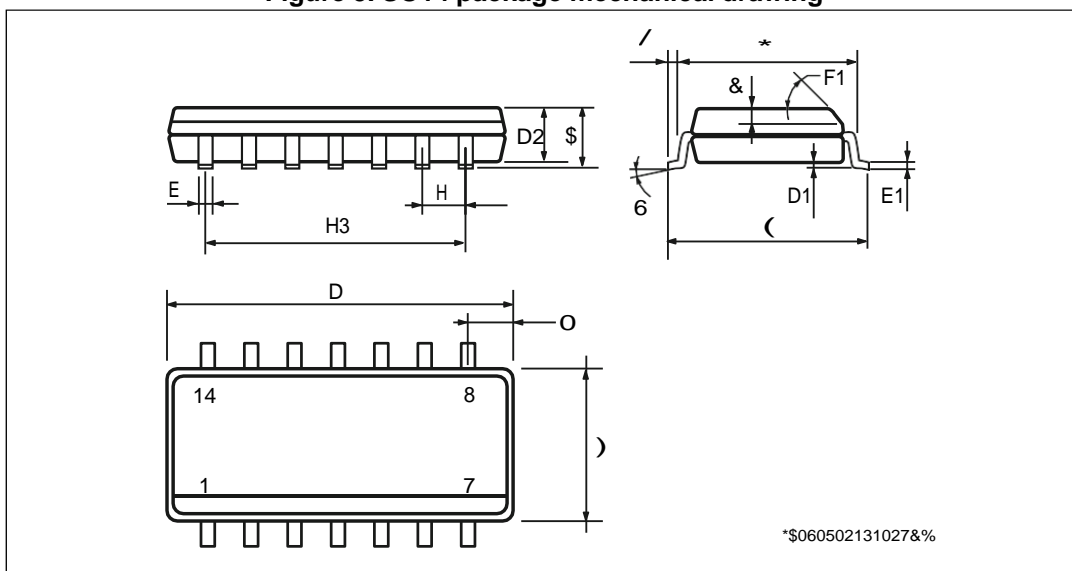
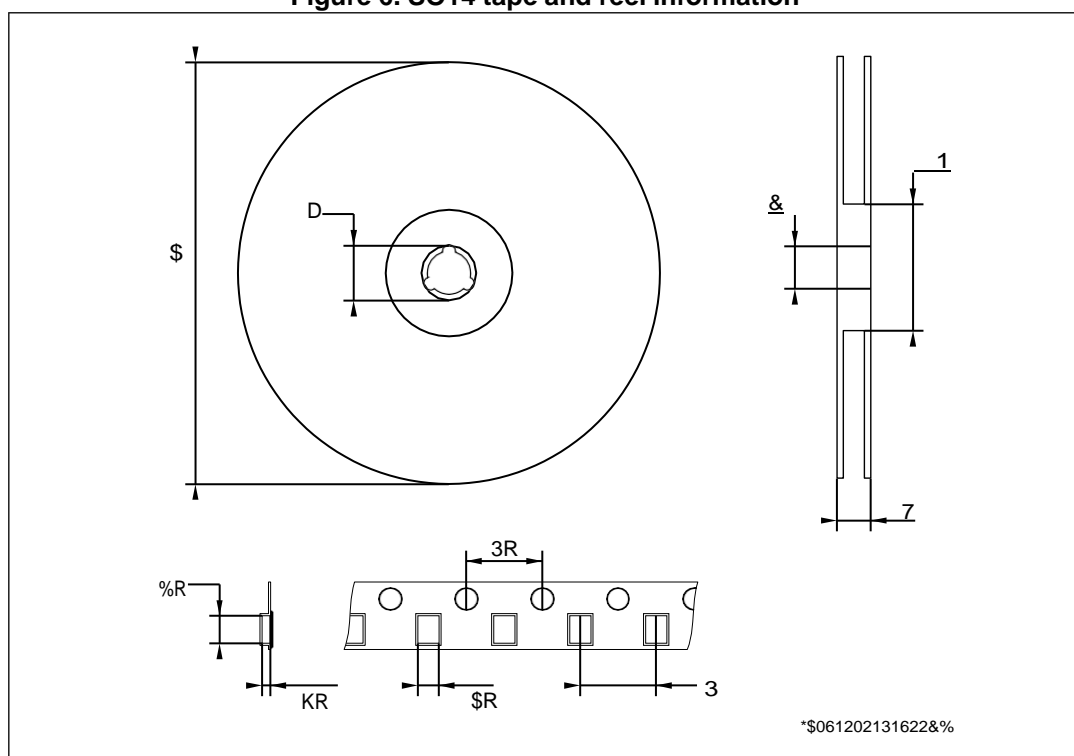

Table 8. SO14 package mechanical data

Ref	Dimensions					
	Millimeters			Inches		
	Min.	Typ.	Max.	Min.	Typ.	Max.
A			1.75			0.068
a1	0.1		0.2	0.003		0.007
a2			1.65			0.064
b	0.35		0.46	0.013		0.018
b1	0.19		0.25	0.007		0.010
C		0.5			0.019	
c1		45 °			45 °	
D	8.55		8.75	0.336		0.344
E	5.8		6.2	0.228		0.244
e		1.27			0.050	
e3		7.62			0.300	
F	3.8		4.0	0.149		0.157
G	4.6		5.3	0.181		0.208
L	0.5		1.27	0.019		0.050
M			0.68			0.026
S			8 °			8 °

Figure 6. SO14 tape and reel information



1. Drawing is not to scale.

Table 9. SO14 tape and reel information

Ref	Dimensions					
	Millimeters			Inches		
	Min.	Typ.	Max.	Min.	Typ.	Max.
A			330			12.992
C	12.8		13.2	0.504		0.519
D	20.2			0.795		
N	60			2.362		
T			22.4			0.882
Ao	6.4		6.6	0.252		0.260
Bo	9		9.2	0.354		0.362
Ko	2.1		2.3	0.082		0.090
Po	3.9		4.1	0.153		0.161
P	7.9		8.1	0.311		0.319

5 Ordering information

Table 10. Order codes

Order code	Temperature range	Package	Packing	Marking
HCF4093M013TR	-55 ° C to +125 ° C	SO14	Tape and reel	HCF4093
HCF4093YM013TR (1)	-40 ° C to +125 ° C	SO14 (automotive grade) ⁽¹⁾		HCF4093Y

1. Qualification and characterization according to AEC Q100 and Q003 or equivalent, advanced screening according to AEC Q001 & Q002 or equivalent.

6 Revision history

Table 11. Document revision history

Date	Revision	Changes
Sept-2001	1	Initial release.
16-Aug-2007	2	Document converted to new ST template, added Figure 6: SO14 tape and reel information on page 11 and Table 9: SO14 tape and reel information on page 11 , small text changes.
18-Feb-2013	3	Document template and layout updated Updated package names (PDIP-14 and SO-14 instead of DIP-14 and SOP-14). Updated Features Added Applications Updated Device summary table Small correction to inches min value of Ao in Table 9 Added Section 5: Ordering information
13-Jan-2014	4	Removed PDIP14 package Added ESD data to Features Table 1: Device summary table : updated footnote 1. Table 10: Order codes : updated footnote 1.

Please Read Carefully:

Information in this document is provided solely in connection with ST products. STMicroelectronics NV and its subsidiaries ("ST") reserve the right to make changes, corrections, modifications or improvements, to this document, and the products and services described herein at any time, without notice.

All ST products are sold pursuant to ST's terms and conditions of sale.

Purchasers are solely responsible for the choice, selection and use of the ST products and services described herein, and ST assumes no liability whatsoever relating to the choice, selection or use of the ST products and services described herein.

No license, express or implied, by estoppel or otherwise, to any intellectual property rights is granted under this document. If any part of this document refers to any third party products or services it shall not be deemed a license grant by ST for the use of such third party products or services, or any intellectual property contained therein or considered as a warranty covering the use in any manner whatsoever of such third party products or services or any intellectual property contained therein.

UNLESS OTHERWISE SET FORTH IN ST'S TERMS AND CONDITIONS OF SALE ST DISCLAIMS ANY EXPRESS OR IMPLIED WARRANTY WITH RESPECT TO THE USE AND/OR SALE OF ST PRODUCTS INCLUDING WITHOUT LIMITATION IMPLIED WARRANTIES OF MERCHANTABILITY, FITNESS FOR A PARTICULAR PURPOSE (AND THEIR EQUIVALENTS UNDER THE LAWS OF ANY JURISDICTION), OR INFRINGEMENT OF ANY PATENT, COPYRIGHT OR OTHER INTELLECTUAL PROPERTY RIGHT.

ST PRODUCTS ARE NOT DESIGNED OR AUTHORIZED FOR USE IN: (A) SAFETY CRITICAL APPLICATIONS SUCH AS LIFE SUPPORTING, ACTIVE IMPLANTED DEVICES OR SYSTEMS WITH PRODUCT FUNCTIONAL SAFETY REQUIREMENTS; (B) AERONAUTIC APPLICATIONS; (C) AUTOMOTIVE APPLICATIONS OR ENVIRONMENTS, AND/OR (D) AEROSPACE APPLICATIONS OR ENVIRONMENTS. WHERE ST PRODUCTS ARE NOT DESIGNED FOR SUCH USE, THE PURCHASER SHALL USE PRODUCTS AT PURCHASER'S SOLE RISK, EVEN IF ST HAS BEEN INFORMED IN WRITING OF SUCH USAGE, UNLESS A PRODUCT IS EXPRESSLY DESIGNATED BY ST AS BEING INTENDED FOR "AUTOMOTIVE, AUTOMOTIVE SAFETY OR MEDICAL" INDUSTRY DOMAINS ACCORDING TO ST PRODUCT DESIGN SPECIFICATIONS. PRODUCTS FORMALLY ESCC, QML OR JAN QUALIFIED ARE DEEMED SUITABLE FOR USE IN AEROSPACE BY THE CORRESPONDING GOVERNMENTAL AGENCY.

Resale of ST products with provisions different from the statements and/or technical features set forth in this document shall immediately void any warranty granted by ST for the ST product or service described herein and shall not create or extend in any manner whatsoever, any liability of ST.

ST and the ST logo are trademarks or registered trademarks of ST in various countries.

Information in this document supersedes and replaces all information previously supplied.

The ST logo is a registered trademark of STMicroelectronics. All other names are the property of their respective owners.

© 2014 STMicroelectronics - All rights reserved

STMicroelectronics group of companies

Australia - Belgium - Brazil - Canada - China - Czech Republic - Finland - France - Germany - Hong Kong - India - Israel - Italy - Japan - Malaysia - Malta - Morocco - Philippines - Singapore - Spain - Sweden - Switzerland - United Kingdom - United States of America

www.st.com

