



# گروه فنی مهندسی جوش و برش مقدم

اعتماد از شما کیفیت و تخصص از ما



09153223758



051-37581400



<https://www.moghadamwelding>



<http://instagram.com/moghadam>



<https://t.me/moghadamwelding>



<https://whatsapp.com/channel>



<https://rubika.ir/moghadamwelding>



مشهد خیام شمالی 63 خیابان پردیس 3

برای کسب اطلاعات بیشتر بر روی لینک ها کلیک کنید

- 7 سال سابقه آموزش تعمیرات تخصصی دستگاه های جوش اینورتری تک فاز و 3 فاز
- 7 سال سابقه فروش قطعات الکترونیکی دستگاه جوش تک فاز و 3 فاز
- آموزش تخصصی تحلیل دستگاه های جوش اینورتری مختص ابراز فروشان
- آموزش تخصصی ابراز آلات شارژی

October 1987  
Revised January 1999

# CD4071BC • CD4081BC

## Quad 2-Input OR Buffered B Series Gate • Quad 2-Input AND Buffered B Series Gate

### General Description

The CD4071BC and CD4081BC quad gates are monolithic complementary MOS (CMOS) integrated circuits constructed with N- and P-channel enhancement mode transistors. They have equal source and sink current capabilities and conform to standard B series output drive. The devices also have buffered outputs which improve transfer characteristics by providing very high gain. All inputs protected against static discharge with diodes to  $V_{DD}$  and  $V_{SS}$ .

### Features

- Low power TTL compatibility:  
Fan out of 2 driving 74L or 1 driving 74LS
- 5V–10V–15V parametric ratings
- Symmetrical output characteristics
- Maximum input leakage 1  $\mu$ A at 15V over full temperature range

### Ordering Code:

Order Number	Package Number	Package Description
CD4071BCM	M14A	14-Lead Small Outline Integrated Circuit (SOIC), JEDEC MS-120, 0.150" Narrow
CD4071BCN	N14A	14-Lead Plastic Dual-In-Line Package (PDIP), JEDEC MS-001, 0.300" Wide
CD4081BCM	M14A	14-Lead Small Outline Integrated Circuit (SOIC), JEDEC MS-120, 0.150" Narrow
CD4081BCN	N14A	14-Lead Plastic Dual-In-Line Package (PDIP), JEDEC MS-001, 0.300" Wide

Devices are also available in Tape and Reel. Specify by appending the suffix letter "X" to the ordering code.

### Connection Diagrams

#### Pin Assignments for DIP and SOIC

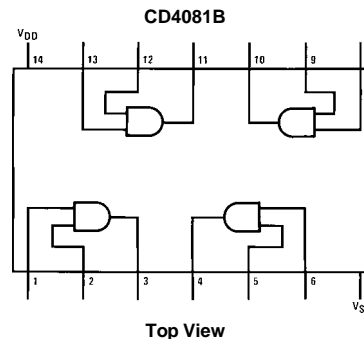
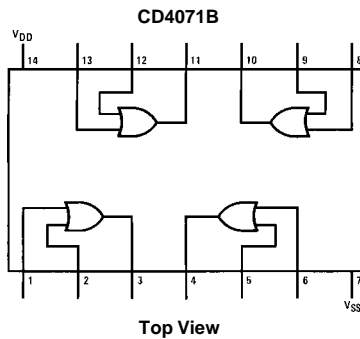

Schematic Diagrams

CD4071B

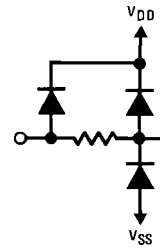
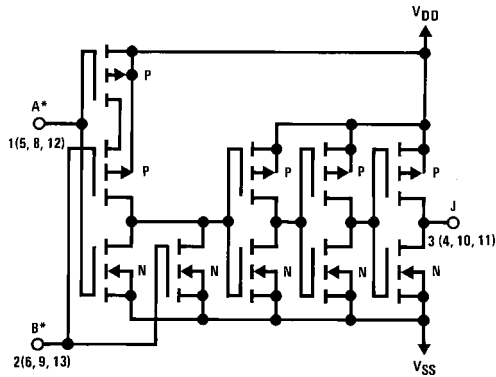

1/4 of device shown  
 $J = A + B$   
 Logical "1" = HIGH  
 Logical "0" = LOW  
 \*All inputs protected by standard CMOS protection circuit.

CD4081B

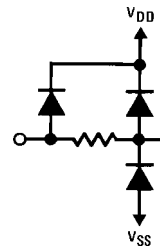
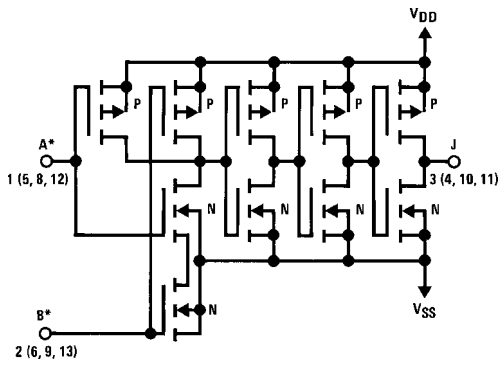

1/4 of device shown  
 $J = A \cdot B$   
 Logical "1" = HIGH  
 Logical "0" = LOW  
 All inputs protected by standard CMOS protection circuit.

### Absolute Maximum Ratings (Note 1)

(Note 2)

Voltage at Any Pin	-0.5V to $V_{DD} + 0.5V$
Power Dissipation ( $P_D$ )	
Dual-In-Line	700 mW
Small Outline	500 mW
$V_{DD}$ Range	-0.5 $V_{DC}$ to +18 $V_{DC}$
Storage Temperature ( $T_S$ )	-65°C to +150°C
Lead Temperature ( $T_L$ )	
(Soldering, 10 seconds)	260°C

### Recommended Operating Conditions

Operating Range ( $V_{DD}$ )	3 $V_{DC}$ to 15 $V_{DC}$
Operating Temperature Range ( $T_A$ )	
CD4071BC, CD4081BC	-40°C to +85°C

**Note 1:** "Absolute Maximum Ratings" are those values beyond which the safety of the device cannot be guaranteed. Except for "Operating Temperature Range" they are not meant to imply that the devices should be operated at these limits. The table of "Electrical Characteristics" provides conditions for actual device operation.

**Note 2:** All voltages measured with respect to  $V_{SS}$  unless otherwise specified.

### DC Electrical Characteristics (Note 2)

CD4071BC/CD4081BC

Symbol	Parameter	Conditions	-40°C		+25°C			+85°C		Units
			Min	Max	Min	Typ	Max	Min	Max	
$I_{DD}$	Quiescent Device Current	$V_{DD} = 5V$		1		0.004	1		7.5	$\mu A$
		$V_{DD} = 10V$		2		0.005	2		15	$\mu A$
		$V_{DD} = 15V$		4		0.006	4		30	$\mu A$
$V_{OL}$	LOW Level Output Voltage	$V_{DD} = 5V$		0.05		0	0.05		0.05	V
		$V_{DD} = 10V$	$ I_O  < 1 \mu A$	0.05		0	0.05		0.05	V
		$V_{DD} = 15V$		0.05		0	0.05		0.05	V
$V_{OH}$	HIGH Level Output Voltage	$V_{DD} = 5V$	4.95		4.95	5		4.95		V
		$V_{DD} = 10V$	9.95		9.95	10		9.95		V
		$V_{DD} = 15V$	14.95		14.95	15		14.95		V
$V_{IL}$	LOW Level Input Voltage	$V_{DD} = 5V, V_O = 0.5V$		1.5		2	1.5		1.5	V
		$V_{DD} = 10V, V_O = 1.0V$		3.0		4	3.0		3.0	V
		$V_{DD} = 15V, V_O = 1.5V$		4.0		6	4.0		4.0	V
$V_{IH}$	HIGH Level Input Voltage	$V_{DD} = 5V, V_O = 4.5V$	3.5		3.5	3		3.5		V
		$V_{DD} = 10V, V_O = 9.0V$	7.0		7.0	6		7.0		V
		$V_{DD} = 15V, V_O = 13.5V$	11.0		11.0	9		11.0		V
$I_{OL}$	LOW Level Output Current (Note 3)	$V_{DD} = 5V, V_O = 0.4V$	0.52		0.44	0.88		0.36		mA
		$V_{DD} = 10V, V_O = 0.5V$	1.3		1.1	2.25		0.9		mA
		$V_{DD} = 15V, V_O = 1.5V$	3.6		3.0	8.8		2.4		mA
$I_{OH}$	HIGH Level Output Current (Note 3)	$V_{DD} = 5V, V_O = 4.6V$	-0.52		-0.44	-0.88		-0.36		mA
		$V_{DD} = 10V, V_O = 9.5V$	-1.3		-1.1	-2.25		-0.9		mA
		$V_{DD} = 15V, V_O = 13.5V$	-3.6		-3.0	-8.8		-2.4		mA
$I_{IN}$	Input Current	$V_{DD} = 15V, V_{IN} = 0V$		-0.30		$-10^{-5}$	-0.30		-1.0	$\mu A$
		$V_{DD} = 15V, V_{IN} = 15V$		0.30		$10^{-5}$	0.30		1.0	$\mu A$

**Note 3:**  $I_{OH}$  and  $I_{OL}$  are tested one output at a time.

### AC Electrical Characteristics (Note 4)

CD4071BC  $T_A = 25^\circ C$ , Input  $t_r, t_f = 20$  ns,  $C_L = 50$  pF,  $R_L = 200$  k $\Omega$ , Typical temperature coefficient is 0.3%/°C

Symbol	Parameter	Conditions	Typ	Max	Units
$t_{PHL}$	Propagation Delay Time, HIGH-to-LOW Level	$V_{DD} = 5V$	100	250	ns
		$V_{DD} = 10V$	40	100	ns
		$V_{DD} = 15V$	30	70	ns
$t_{PLH}$	Propagation Delay Time, LOW-to-HIGH Level	$V_{DD} = 5V$	90	250	ns
		$V_{DD} = 10V$	40	100	ns
		$V_{DD} = 15V$	30	70	ns
$t_{THL}, t_{TLH}$	Transition Time	$V_{DD} = 5V$	90	200	ns
		$V_{DD} = 10V$	50	100	ns
		$V_{DD} = 15V$	40	80	ns
$C_{IN}$	Average Input Capacitance	Any Input	5	7.5	pF
$C_{PD}$	Power Dissipation Capacity	Any Gate	18		pF

**Note 4:** AC Parameters are guaranteed by DC correlated testing.

### AC Electrical Characteristics (Note 5)

CD4081BC  $T_A = 25^\circ\text{C}$ , Input  $t_i$ ;  $t_f = 20\text{ ns}$ ,  $C_L = 50\text{ pF}$ ,  $R_L = 200\text{ k}\Omega$ , Typical temperature coefficient is  $0.3\%/^\circ\text{C}$

Symbol	Parameter	Conditions	Typ	Max	Units
$t_{PHL}$	Propagation Delay Time, HIGH-to-LOW Level	$V_{DD} = 5\text{V}$	100	250	ns
		$V_{DD} = 10\text{V}$	40	100	ns
		$V_{DD} = 15\text{V}$	30	70	ns
$t_{PLH}$	Propagation Delay Time, LOW-to-HIGH Level	$V_{DD} = 5\text{V}$	120	250	ns
		$V_{DD} = 10\text{V}$	50	100	ns
		$V_{DD} = 15\text{V}$	35	70	ns
$t_{THL}, t_{TLH}$	Transition Time	$V_{DD} = 5\text{V}$	90	200	ns
		$V_{DD} = 10\text{V}$	50	100	ns
		$V_{DD} = 15\text{V}$	40	80	ns
$C_{IN}$	Average Input Capacitance	Any Input	5	7.5	pF
$C_{PD}$	Power Dissipation Capacity	Any Gate	18		pF

Note 5: AC Parameters are guaranteed by DC correlated testing.

### Typical Performance Characteristics

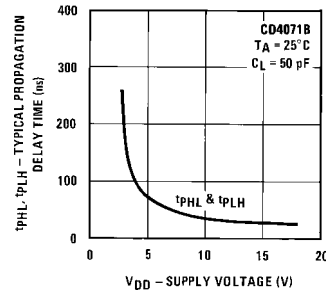
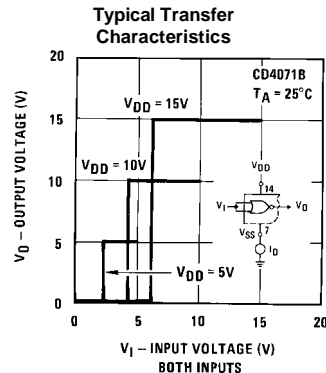
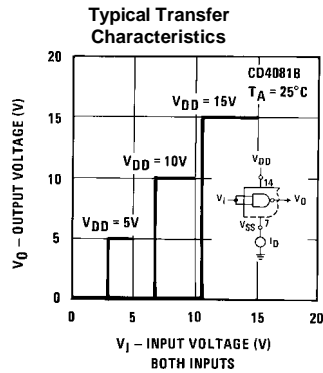
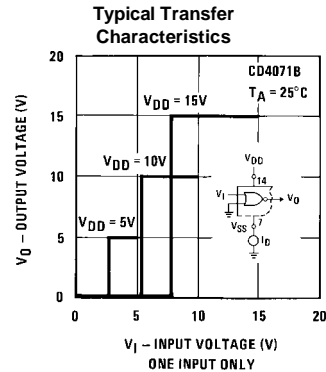
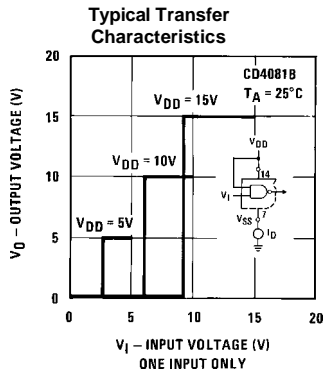

# Typical Performance Characteristics (Continued)

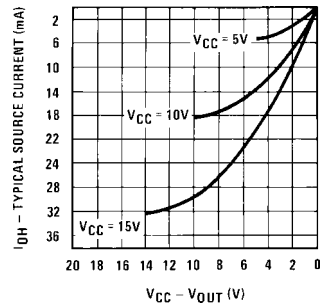
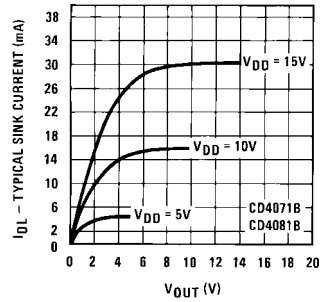
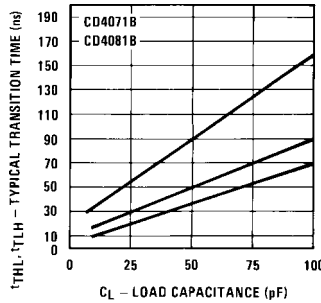
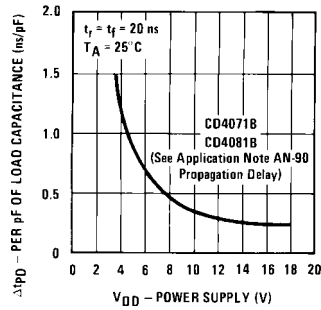
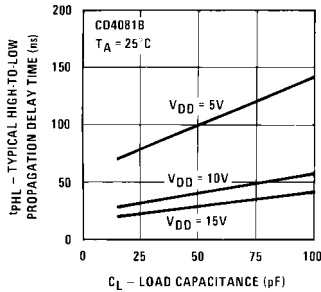
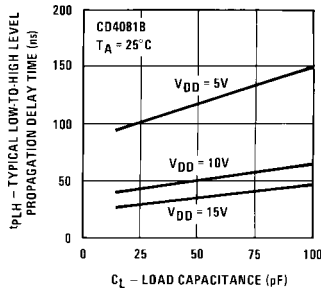
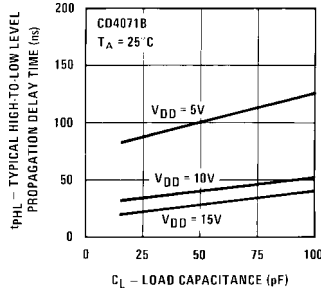
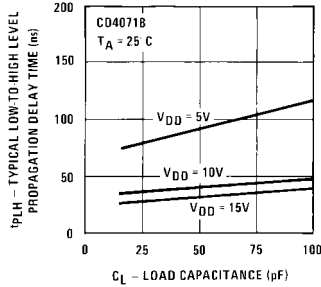
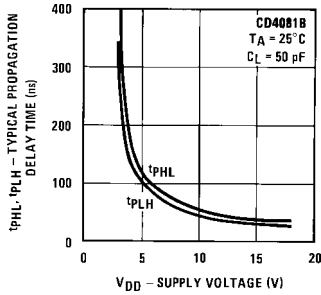

CD4071BC • CD4081BC

**Physical Dimensions** inches (millimeters) unless otherwise noted

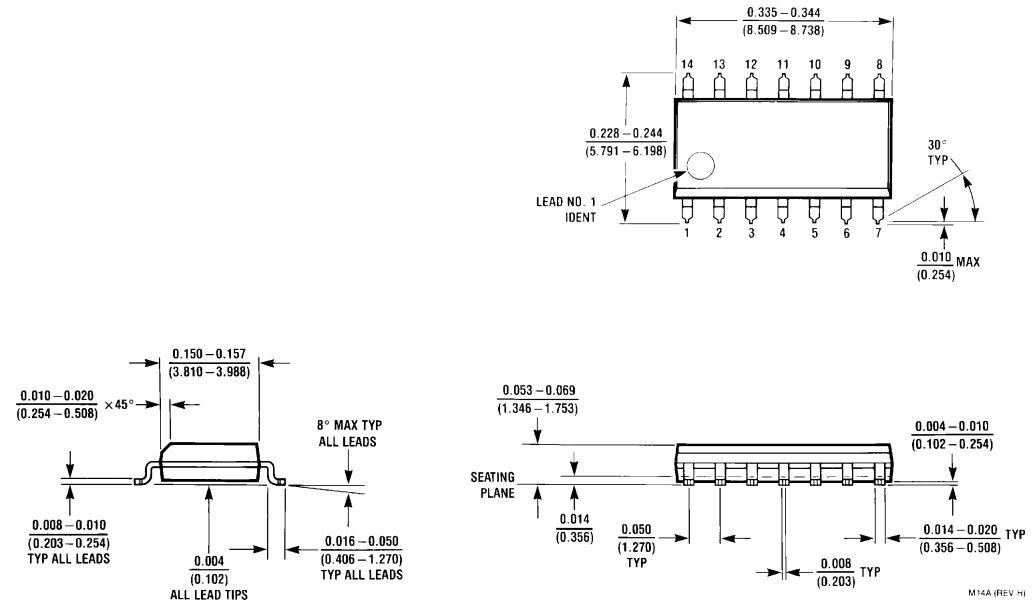

**14-Lead Small Outline Integrated Circuit (SOIC), JEDEC MS-120, 0.150" Narrow  
Package Number M14A**

**Physical Dimensions** inches (millimeters) unless otherwise noted (Continued)

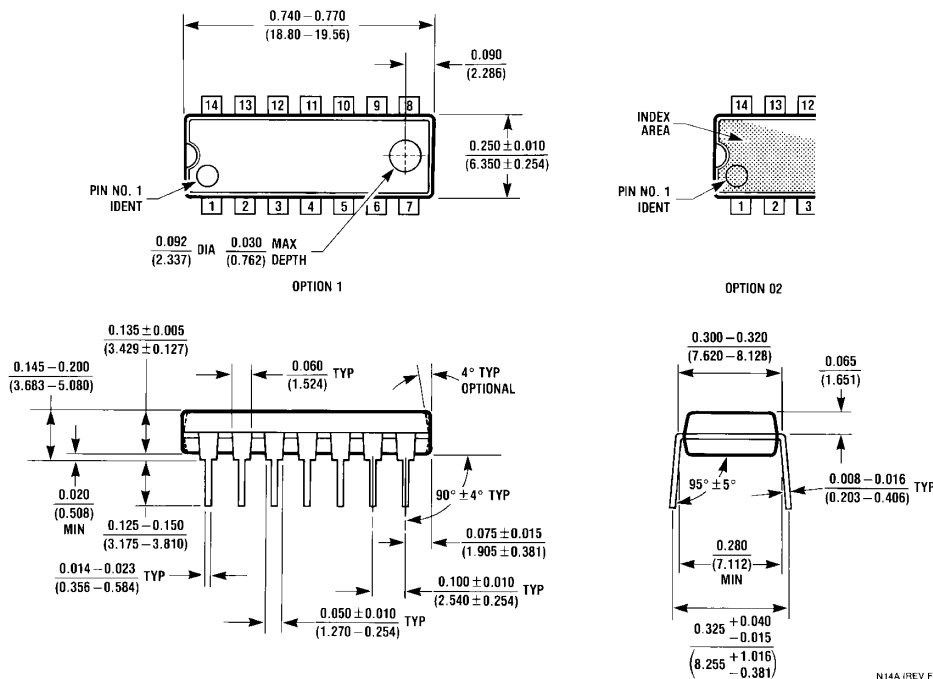

**14-Lead Plastic Dual-In-Line Package (PDIP), JEDEC MS-001, 0.300" Wide Package Number N14A**

**LIFE SUPPORT POLICY**

FAIRCHILD'S PRODUCTS ARE NOT AUTHORIZED FOR USE AS CRITICAL COMPONENTS IN LIFE SUPPORT DEVICES OR SYSTEMS WITHOUT THE EXPRESS WRITTEN APPROVAL OF THE PRESIDENT OF FAIRCHILD SEMICONDUCTOR CORPORATION. As used herein:

1. Life support devices or systems are devices or systems which, (a) are intended for surgical implant into the body, or (b) support or sustain life, and (c) whose failure to perform when properly used in accordance with instructions for use provided in the labeling, can be reasonably expected to result in a significant injury to the user.
2. A critical component in any component of a life support device or system whose failure to perform can be reasonably expected to cause the failure of the life support device or system, or to affect its safety or effectiveness.

[www.fairchildsemi.com](http://www.fairchildsemi.com)



