



گروه فنی مهندسی جوش و برش مقدم

اعتماد از شما کیفیت و تخصص از ما



09153223758



051-37581400



<https://www.moghadamwelding>



<http://instagram.com/moghadam>



<https://t.me/moghadamwelding>



<https://whatsapp.com/channel>



<https://rubika.ir/moghadamwelding>



مشهد خیام شمالی 63 خیابان پردیس 3

برای کسب اطلاعات بیشتر بر روی لینک ها کلیک کنید

- 7 سال سابقه آموزش تعمیرات تخصصی دستگاه های جوش اینورتری تک فاز و 3 فاز
- 7 سال سابقه فروش قطعات الکترونیکی دستگاه جوش تک فاز و 3 فاز
- آموزش تخصصی تحلیل دستگاه های جوش اینورتری مختص ابراز فروشان
- آموزش تخصصی ابراز آلات شارژی

Positive voltage regulator ICs

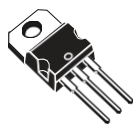

TO-220

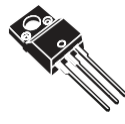

TO-220FP



DPAK

 D²PAK

Features

- Output current up to 1.5 A
- Output voltages of 5; 6; 8; 8.5; 9; 12; 15; 18; 24 V
- Thermal overload protection
- Short circuit protection
- Output transition SOA protection
- 2 % output voltage tolerance (A version)
- Guaranteed in extended temperature range (A version)

Description

The L78 series of three-terminal positive regulators is available in TO-220, TO-220FP, D²PAK and DPAK packages and several fixed output voltages, making it useful in a wide range of applications.

These regulators can provide local on-card regulation, eliminating the distribution problems associated with single point regulation. Each type embeds internal current limiting, thermal shut-down and safe area protection, making it essentially indestructible. If adequate heat sinking is provided, they can deliver over 1 A output current. Although designed primarily as fixed voltage regulators, these devices can be used with external components to obtain adjustable voltage and currents.

Maturity status link

L78

1 Diagram

Figure 2. Block diagram

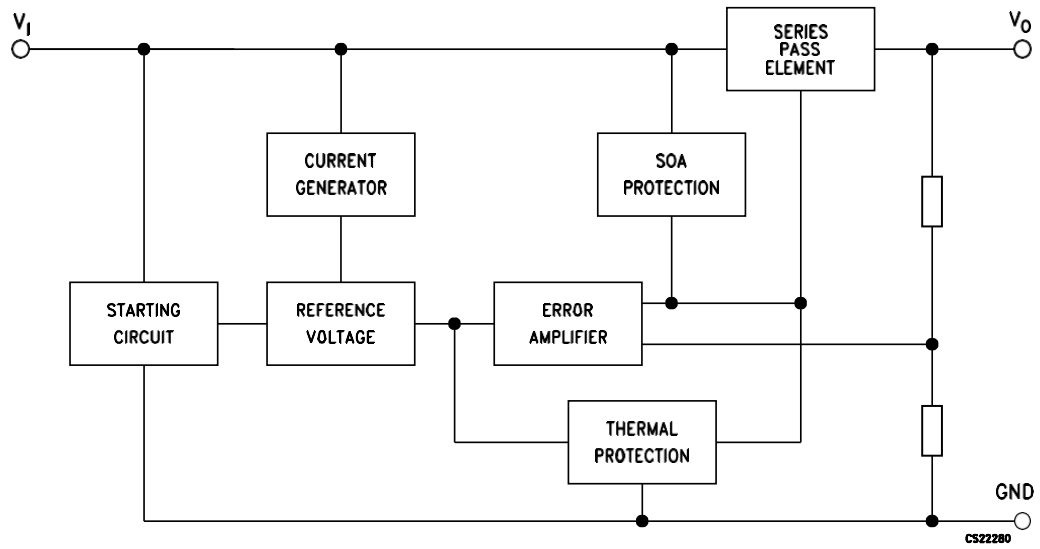

GAMG220920161000MT

2 Pin configuration

Figure 3. Pin connections (top view)

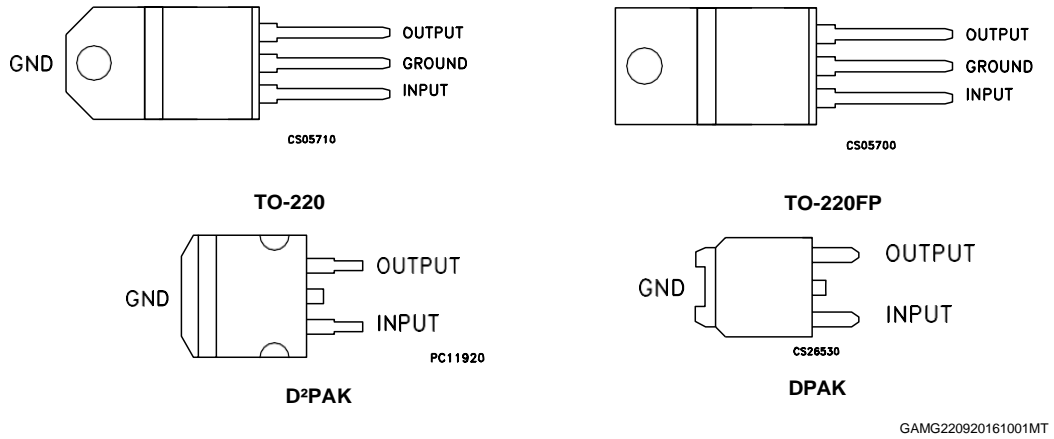
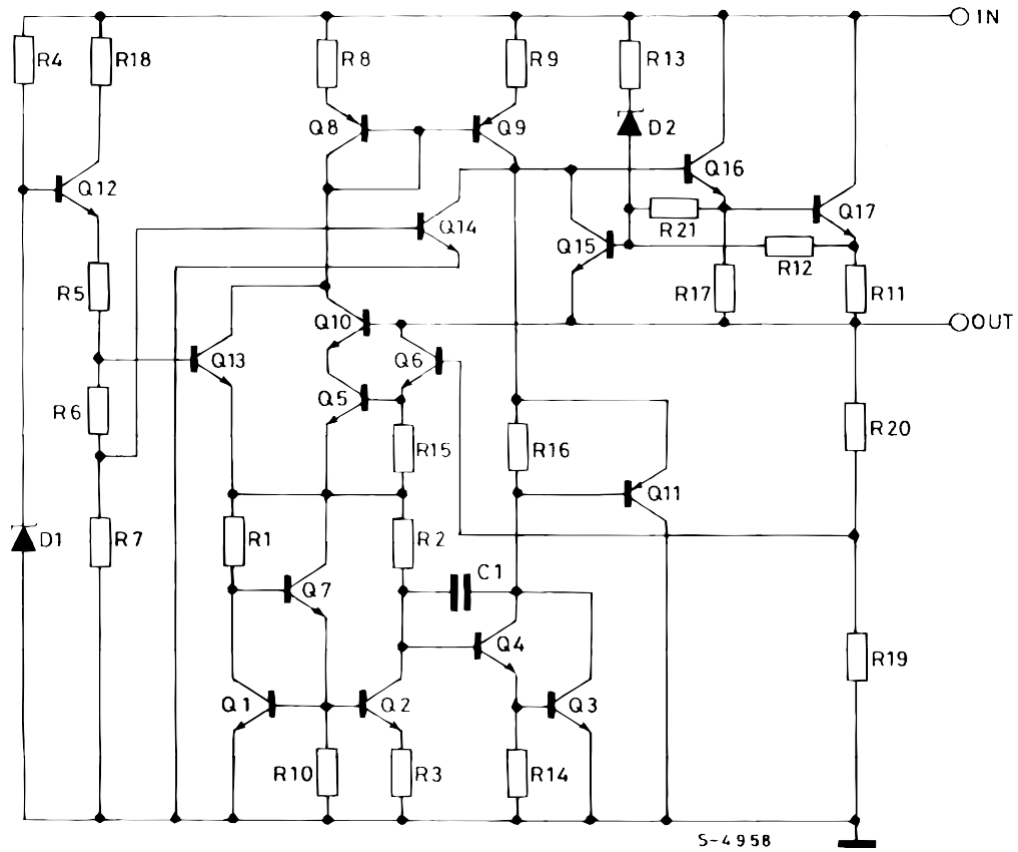

Figure 4. Schematic diagram



GAMG220920161002MT

3 Maximum ratings

Table 1. Absolute maximum ratings

Symbol	Parameter	Value	Unit
V_I	DC input voltage	for $V_O = 5$ to 18 V	35
		for $V_O = 20, 24$ V	40
I_O	Output current	Internally limited	
P_D	Power dissipation	Internally limited	
T_{STG}	Storage temperature range	-65 to 150	°C
T_{OP}	Operating junction temperature range	for L78xxC, L78xxAC	0 to 125
		for L78xxAB	-40 to 125

Note: Absolute maximum ratings are those values beyond which damage to the device may occur. Functional operation under these condition is not implied.

Table 2. Thermal data

Symbol	Parameter	D ² PAK	DPAK	TO-220	TO-220FP	Unit
R_{thJC}	Thermal resistance junction-case	3	8	5	5	°C/W
R_{thJA}	Thermal resistance junction-ambient	62.5	100	50	60	°C/W

Figure 5. Application circuits

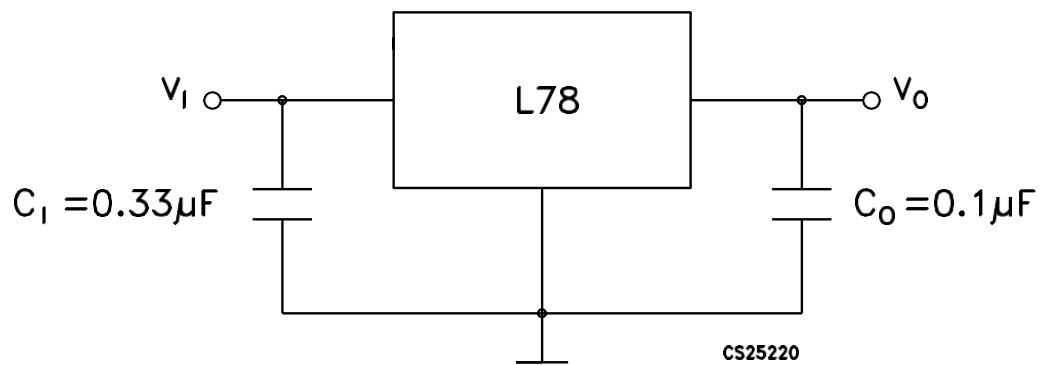

GAMG220920161003MT

4 Test circuits

Figure 6. DC parameter

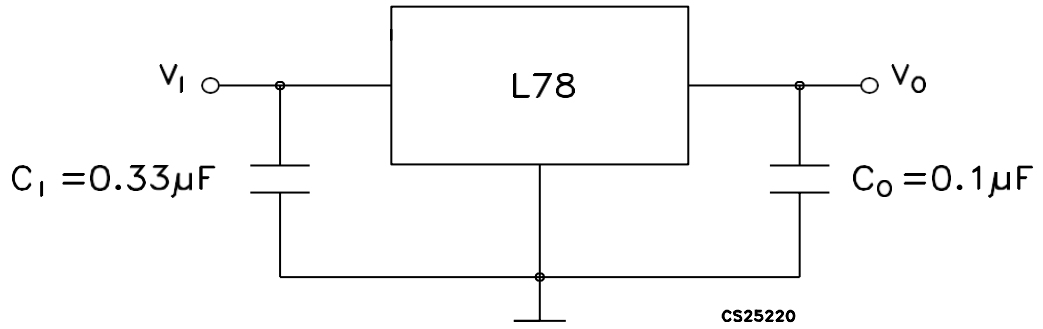

GAMG220920161004MT

Figure 7. Load regulation

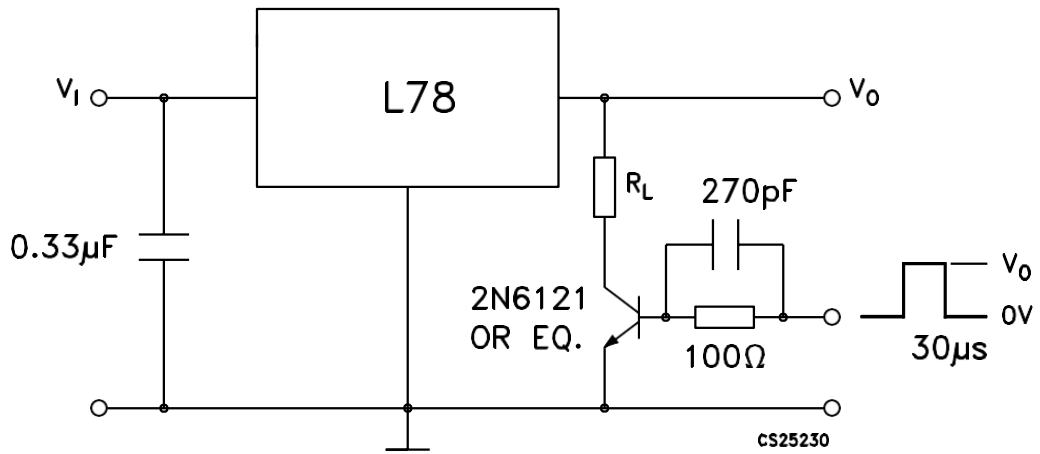

GAMG220920161005MT

Figure 8. Ripple rejection

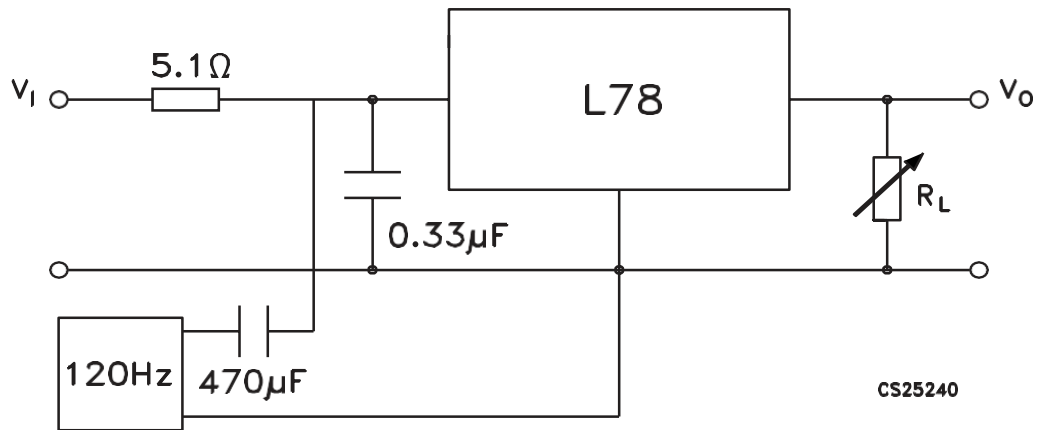

GAMG220920161006MT

5 Electrical characteristics

$V_I = 10\text{ V}$, $I_O = 1\text{ A}$, $T_J = 0\text{ to }125\text{ °C}$ (L7805AC), $T_J = -40\text{ to }125\text{ °C}$ (L7805AB), unless otherwise specified.

Table 3. Electrical characteristics of L7805A

Symbol	Parameter	Test conditions	Min.	Typ.	Max.	Unit
V_O	Output voltage	$T_J = 25\text{ °C}$	4.9	5	5.1	V
V_O	Output voltage	$I_O = 5\text{ mA to }1\text{ A}$, $V_I = 7.5\text{ to }18\text{ V}$	4.8	5	5.2	V
V_O	Output voltage	$I_O = 1\text{ A}$, $V_I = 18\text{ to }20\text{ V}$, $T_J = 25\text{ °C}$	4.8	5	5.2	V
$\Delta V_O^{(1)}$	Line regulation	$V_I = 7.5\text{ to }25\text{ V}$, $I_O = 500\text{ mA}$, $T_J = 25\text{ °C}$		7	50	mV
		$V_I = 8\text{ to }12\text{ V}$		10	50	mV
		$V_I = 8\text{ to }12\text{ V}$, $T_J = 25\text{ °C}$		2	25	mV
		$V_I = 7.3\text{ to }20\text{ V}$, $T_J = 25\text{ °C}$		7	50	mV
$\Delta V_O^{(1)}$	Load regulation	$I_O = 5\text{ mA to }1\text{ A}$		25	100	mV
		$I_O = 5\text{ mA to }1.5\text{ A}$, $T_J = 25\text{ °C}$		30	100	
		$I_O = 250\text{ to }750\text{ mA}$		8	50	
I_q	Quiescent current	$T_J = 25\text{ °C}$		4.3	6	mA
					6	mA
ΔI_q	Quiescent current change	$V_I = 8\text{ to }23\text{ V}$, $I_O = 500\text{ mA}$			0.8	mA
		$V_I = 7.5\text{ to }20\text{ V}$, $T_J = 25\text{ °C}$			0.8	mA
		$I_O = 5\text{ mA to }1\text{ A}$			0.5	mA
SVR	Supply voltage rejection	$V_I = 8\text{ to }18\text{ V}$, $f = 120\text{ Hz}$, $I_O = 500\text{ mA}$		68		dB
V_d	Dropout voltage	$I_O = 1\text{ A}$, $T_J = 25\text{ °C}$		2		V
eN	Output noise voltage	$T_A = 25\text{ °C}$, $B = 10\text{ Hz to }100\text{ kHz}$		10		$\mu\text{V}/V_O$
R_O	Output resistance	$f = 1\text{ kHz}$		17		m Ω
I_{sc}	Short circuit current	$V_I = 35\text{ V}$, $T_A = 25\text{ °C}$		0.2		A
I_{scp}	Short circuit peak current	$T_J = 25\text{ °C}$		2.2		A
$\Delta V_O/\Delta T$	Output voltage drift			-1.1		mV/°C

1. Load and line regulation are specified at constant junction temperature. Changes in V_O due to heating effects must be taken into account separately. Pulse testing with low duty cycle is used.

Note: Minimum load current for regulation is 5 mA.

$V_I = 11\text{ V}$, $I_O = 1\text{ A}$, $T_J = 0\text{ to }125\text{ °C}$ (L7806AC), $T_J = -40\text{ to }125\text{ °C}$ (L7806AB), unless otherwise specified.

Table 4. Electrical characteristics of L7806A

Symbol	Parameter	Test conditions	Min.	Typ.	Max.	Unit
V_O	Output voltage	$T_J = 25\text{ °C}$	5.88	6	6.12	V
V_O	Output voltage	$I_O = 5\text{ mA to }1\text{ A}$, $V_I = 8.6\text{ to }19\text{ V}$	5.76	6	6.24	V
V_O	Output voltage	$I_O = 1\text{ A}$, $V_I = 19\text{ to }21\text{ V}$, $T_J = 25\text{ °C}$	5.76	6	6.24	V
$\Delta V_O^{(1)}$	Line regulation	$V_I = 8.6\text{ to }25\text{ V}$, $I_O = 500\text{ mA}$, $T_J = 25\text{ °C}$		9	60	mV
		$V_I = 9\text{ to }13\text{ V}$		11	60	mV
		$V_I = 9\text{ to }13\text{ V}$, $T_J = 25\text{ °C}$		3	30	mV
		$V_I = 8.3\text{ to }21\text{ V}$, $T_J = 25\text{ °C}$		9	60	mV
$\Delta V_O^{(1)}$	Load regulation	$I_O = 5\text{ mA to }1\text{ A}$		25	100	mV
		$I_O = 5\text{ mA to }1.5\text{ A}$, $T_J = 25\text{ °C}$		30	100	
		$I_O = 250\text{ to }750\text{ mA}$		10	50	
I_q	Quiescent current	$T_J = 25\text{ °C}$		4.3	6	mA
					6	mA
ΔI_q	Quiescent current change	$V_I = 9\text{ to }24\text{ V}$, $I_O = 500\text{ mA}$			0.8	mA
		$V_I = 8.6\text{ to }21\text{ V}$, $T_J = 25\text{ °C}$			0.8	mA
		$I_O = 5\text{ mA to }1\text{ A}$			0.5	mA
SVR	Supply voltage rejection	$V_I = 9\text{ to }19\text{ V}$, $f = 120\text{ Hz}$, $I_O = 500\text{ mA}$		65		dB
V_d	Dropout voltage	$I_O = 1\text{ A}$, $T_J = 25\text{ °C}$		2		V
eN	Output noise voltage	$T_A = 25\text{ °C}$, $B = 10\text{ Hz to }100\text{ kHz}$		10		$\mu\text{V}/V_O$
R_O	Output resistance	$f = 1\text{ kHz}$		17		m Ω
I_{sc}	Short circuit current	$V_I = 35\text{ V}$, $T_A = 25\text{ °C}$		0.2		A
I_{scp}	Short circuit peak current	$T_J = 25\text{ °C}$		2.2		A
$\Delta V_O/\Delta T$	Output voltage drift			-0.8		mV/°C

1. Load and line regulation are specified at constant junction temperature. Changes in V_O due to heating effects must be taken into account separately. Pulse testing with low duty cycle is used.

Note: Minimum load current for regulation is 5 mA.

$V_I = 14\text{ V}$, $I_O = 1\text{ A}$, $T_J = 0\text{ to }125\text{ °C}$ (L7808AC), $T_J = -40\text{ to }125\text{ °C}$ (L7808AB), unless otherwise specified.

Table 5. Electrical characteristics of L7808A

Symbol	Parameter	Test conditions	Min.	Typ.	Max.	Unit
V_O	Output voltage	$T_J = 25\text{ °C}$	7.84	8	8.16	V
V_O	Output voltage	$I_O = 5\text{ mA to }1\text{ A}$, $V_I = 10.6\text{ to }21\text{ V}$	7.7	8	8.3	V
V_O	Output voltage	$I_O = 1\text{ A}$, $V_I = 21\text{ to }23\text{ V}$, $T_J = 25\text{ °C}$	7.7	8	8.3	V
$\Delta V_O^{(1)}$	Line regulation	$V_I = 10.6\text{ to }25\text{ V}$, $I_O = 500\text{ mA}$, $T_J = 25\text{ °C}$		12	80	mV
		$V_I = 11\text{ to }17\text{ V}$		15	80	mV
		$V_I = 11\text{ to }17\text{ V}$, $T_J = 25\text{ °C}$		5	40	mV
		$V_I = 10.4\text{ to }23\text{ V}$, $T_J = 25\text{ °C}$		12	80	mV
$\Delta V_O^{(1)}$	Load regulation	$I_O = 5\text{ mA to }1\text{ A}$		25	100	mV
		$I_O = 5\text{ mA to }1.5\text{ A}$, $T_J = 25\text{ °C}$		30	100	
		$I_O = 250\text{ to }750\text{ mA}$		10	50	
I_q	Quiescent current	$T_J = 25\text{ °C}$		4.3	6	mA
					6	mA
ΔI_q	Quiescent current change	$V_I = 11\text{ to }23\text{ V}$, $I_O = 500\text{ mA}$			0.8	mA
		$V_I = 10.6\text{ to }23\text{ V}$, $T_J = 25\text{ °C}$			0.8	mA
		$I_O = 5\text{ mA to }1\text{ A}$			0.5	mA
SVR	Supply voltage rejection	$V_I = 11.5\text{ to }21.5\text{ V}$, $f = 120\text{ Hz}$, $I_O = 500\text{ mA}$		62		dB
V_d	Dropout voltage	$I_O = 1\text{ A}$, $T_J = 25\text{ °C}$		2		V
eN	Output noise voltage	$T_A = 25\text{ °C}$, $B = 10\text{ Hz to }100\text{ kHz}$		10		$\mu\text{V}/V_O$
R_O	Output resistance	$f = 1\text{ kHz}$		18		m Ω
I_{sc}	Short circuit current	$V_I = 35\text{ V}$, $T_A = 25\text{ °C}$		0.2		A
I_{scp}	Short circuit peak current	$T_J = 25\text{ °C}$		2.2		A
$\Delta V_O/\Delta T$	Output voltage drift			-0.8		mV/°C

1. Load and line regulation are specified at constant junction temperature. Changes in V_O due to heating effects must be taken into account separately. Pulse testing with low duty cycle is used.

Note: Minimum load current for regulation is 5 mA.

$V_I = 15\text{ V}$, $I_O = 1\text{ A}$, $T_J = 0\text{ to }125\text{ °C}$ (L7809AC), $T_J = -40\text{ to }125\text{ °C}$ (L7809AB), unless otherwise specified (Minimum load current for regulation is 5 mA.)

Table 6. Electrical characteristics of L7809A

Symbol	Parameter	Test conditions	Min.	Typ.	Max.	Unit
V_O	Output voltage	$T_J = 25\text{ °C}$	8.82	9	9.18	V
V_O	Output voltage	$I_O = 5\text{ mA to }1\text{ A}$, $V_I = 10.6\text{ to }22\text{ V}$	8.65	9	9.35	V
V_O	Output voltage	$I_O = 1\text{ A}$, $V_I = 22\text{ to }24\text{ V}$, $T_J = 25\text{ °C}$	8.65	9	9.35	V
$\Delta V_O^{(1)}$	Line regulation	$V_I = 10.6\text{ to }25\text{ V}$, $I_O = 500\text{ mA}$, $T_J = 25\text{ °C}$		12	90	mV
		$V_I = 11\text{ to }17\text{ V}$		15	90	mV
		$V_I = 11\text{ to }17\text{ V}$, $T_J = 25\text{ °C}$		5	45	mV
		$V_I = 11.4\text{ to }23\text{ V}$, $T_J = 25\text{ °C}$		12	90	mV
$\Delta V_O^{(1)}$	Load regulation	$I_O = 5\text{ mA to }1\text{ A}$		25	100	mV
		$I_O = 5\text{ mA to }1.5\text{ A}$, $T_J = 25\text{ °C}$		30	100	
		$I_O = 250\text{ to }750\text{ mA}$		10	50	
I_q	Quiescent current	$T_J = 25\text{ °C}$		4.3	6	mA
					6	mA
ΔI_q	Quiescent current change	$V_I = 11\text{ to }25\text{ V}$, $I_O = 500\text{ mA}$			0.8	mA
		$V_I = 10.6\text{ to }23\text{ V}$, $T_J = 25\text{ °C}$			0.8	mA
		$I_O = 5\text{ mA to }1\text{ A}$			0.5	mA
SVR	Supply voltage rejection	$V_I = 11.5\text{ to }21.5\text{ V}$, $f = 120\text{ Hz}$, $I_O = 500\text{ mA}$		61		dB
V_d	Dropout voltage	$I_O = 1\text{ A}$, $T_J = 25\text{ °C}$		2		V
eN	Output noise voltage	$T_A = 25\text{ °C}$, $B = 10\text{ Hz to }100\text{ kHz}$		10		$\mu\text{V}/V_O$
R_O	Output resistance	$f = 1\text{ kHz}$		18		m Ω
I_{sc}	Short circuit current	$V_I = 35\text{ V}$, $T_A = 25\text{ °C}$		0.2		A
I_{scp}	Short circuit peak current	$T_J = 25\text{ °C}$		2.2		A
$\Delta V_O/\Delta T$	Output voltage drift			-0.8		mV/°C

1. Load and line regulation are specified at constant junction temperature. Changes in V_O due to heating effects must be taken into account separately. Pulse testing with low duty cycle is used.

Note: Minimum load current for regulation is 5 mA.

$V_I = 19\text{ V}$, $I_O = 1\text{ A}$, $T_J = 0\text{ to }125\text{ °C}$ (L7812AC), $T_J = -40\text{ to }125\text{ °C}$ (L7812AB), unless otherwise specified.

Table 7. Electrical characteristics of L7812A

Symbol	Parameter	Test conditions	Min.	Typ.	Max.	Unit
V_O	Output voltage	$T_J = 25\text{ °C}$	11.75	12	12.25	V
V_O	Output voltage	$I_O = 5\text{ mA to }1\text{ A}$, $V_I = 14.8\text{ to }25\text{ V}$	11.5	12	12.5	V
V_O	Output voltage	$I_O = 1\text{ A}$, $V_I = 25\text{ to }27\text{ V}$, $T_J = 25\text{ °C}$	11.5	12	12.5	V
$\Delta V_O^{(1)}$	Line regulation	$V_I = 14.8\text{ to }30\text{ V}$, $I_O = 500\text{ mA}$, $T_J = 25\text{ °C}$		13	120	mV
		$V_I = 16\text{ to }12\text{ V}$		16	120	mV
		$V_I = 16\text{ to }12\text{ V}$, $T_J = 25\text{ °C}$		6	60	mV
		$V_I = 14.5\text{ to }27\text{ V}$, $T_J = 25\text{ °C}$		13	120	mV
$\Delta V_O^{(1)}$	Load regulation	$I_O = 5\text{ mA to }1\text{ A}$		25	100	mV
		$I_O = 5\text{ mA to }1.5\text{ A}$, $T_J = 25\text{ °C}$		30	100	
		$I_O = 250\text{ to }750\text{ mA}$		10	50	
I_q	Quiescent current	$T_J = 25\text{ °C}$		4.4	6	mA
					6	mA
ΔI_q	Quiescent current change	$V_I = 15\text{ to }30\text{ V}$, $I_O = 500\text{ mA}$			0.8	mA
		$V_I = 14.8\text{ to }27\text{ V}$, $T_J = 25\text{ °C}$			0.8	mA
		$I_O = 5\text{ mA to }1\text{ A}$			0.5	mA
SVR	Supply voltage rejection	$V_I = 15\text{ to }25\text{ V}$, $f = 120\text{ Hz}$, $I_O = 500\text{ mA}$		60		dB
V_d	Dropout voltage	$I_O = 1\text{ A}$, $T_J = 25\text{ °C}$		2		V
eN	Output noise voltage	$T_A = 25\text{ °C}$, $B = 10\text{ Hz to }100\text{ kHz}$		10		$\mu\text{V}/V_O$
R_O	Output resistance	$f = 1\text{ kHz}$		18		m Ω
I_{sc}	Short circuit current	$V_I = 35\text{ V}$, $T_A = 25\text{ °C}$		0.2		A
I_{scp}	Short circuit peak current	$T_J = 25\text{ °C}$		2.2		A
$\Delta V_O/\Delta T$	Output voltage drift			-1		mV/°C

1. Load and line regulation are specified at constant junction temperature. Changes in V_O due to heating effects must be taken into account separately. Pulse testing with low duty cycle is used.

Note: Minimum load current for regulation is 5 mA.

$V_I = 23\text{ V}$, $I_O = 1\text{ A}$, $T_J = 0\text{ to }125\text{ °C}$ (L7815AC), $T_J = -40\text{ to }125\text{ °C}$ (L7815AB), unless otherwise specified.

Table 8. Electrical characteristics of L7815A

Symbol	Parameter	Test conditions	Min.	Typ.	Max.	Unit
V_O	Output voltage	$T_J = 25\text{ °C}$	14.7	15	15.3	V
V_O	Output voltage	$I_O = 5\text{ mA to }1\text{ A}$, $V_I = 17.9\text{ to }28\text{ V}$	14.4	15	15.6	V
V_O	Output voltage	$I_O = 1\text{ A}$, $V_I = 28\text{ to }30\text{ V}$, $T_J = 25\text{ °C}$	14.4	15	15.6	V
$\Delta V_O^{(1)}$	Line regulation	$V_I = 17.9\text{ to }30\text{ V}$, $I_O = 500\text{ mA}$, $T_J = 25\text{ °C}$		13	150	mV
		$V_I = 20\text{ to }26\text{ V}$		16	150	mV
		$V_I = 20\text{ to }26\text{ V}$, $T_J = 25\text{ °C}$		6	75	mV
		$V_I = 17.5\text{ to }30\text{ V}$, $T_J = 25\text{ °C}$		13	150	mV
$\Delta V_O^{(1)}$	Load regulation	$I_O = 5\text{ mA to }1\text{ A}$		25	100	mV
		$I_O = 5\text{ mA to }1.5\text{ A}$, $T_J = 25\text{ °C}$		30	100	
		$I_O = 250\text{ to }750\text{ mA}$		10	50	
I_q	Quiescent current	$T_J = 25\text{ °C}$		4.4	6	mA
					6	mA
ΔI_q	Quiescent current change	$V_I = 17.5\text{ to }30\text{ V}$, $I_O = 500\text{ mA}$			0.8	mA
		$V_I = 17.5\text{ to }30\text{ V}$, $T_J = 25\text{ °C}$			0.8	mA
		$I_O = 5\text{ mA to }1\text{ A}$			0.5	mA
SVR	Supply voltage rejection	$V_I = 18.5\text{ to }28.5\text{ V}$, $f = 120\text{ Hz}$, $I_O = 500\text{ mA}$		58		dB
V_d	Dropout voltage	$I_O = 1\text{ A}$, $T_J = 25\text{ °C}$		2		V
eN	Output noise voltage	$T_A = 25\text{ °C}$, $B = 10\text{ Hz to }100\text{ kHz}$		10		$\mu\text{V}/V_O$
R_O	Output resistance	$f = 1\text{ kHz}$		19		m Ω
I_{sc}	Short circuit current	$V_I = 35\text{ V}$, $T_A = 25\text{ °C}$		0.2		A
I_{scp}	Short circuit peak current	$T_J = 25\text{ °C}$		2.2		A
$\Delta V_O/\Delta T$	Output voltage drift			-1		mV/°C

1. Load and line regulation are specified at constant junction temperature. Changes in V_O due to heating effects must be taken into account separately. Pulse testing with low duty cycle is used.

Note: Minimum load current for regulation is 5 mA.

$V_I = 33\text{ V}$, $I_O = 1\text{ A}$, $T_J = 0\text{ to }125\text{ °C}$ (L7824AC), $T_J = -40\text{ to }125\text{ °C}$ (L7824AB), unless otherwise specified.

Table 9. Electrical characteristics of L7824A

Symbol	Parameter	Test conditions	Min.	Typ.	Max.	Unit
V_O	Output voltage	$T_J = 25\text{ °C}$	23.5	24	24.5	V
V_O	Output voltage	$I_O = 5\text{ mA to }1\text{ A}$, $V_I = 27.3\text{ to }37\text{ V}$	23	24	25	V
V_O	Output voltage	$I_O = 1\text{ A}$, $V_I = 37\text{ to }38\text{ V}$, $T_J = 25\text{ °C}$	23	24	25	V
$\Delta V_O^{(1)}$	Line regulation	$V_I = 27\text{ to }38\text{ V}$, $I_O = 500\text{ mA}$, $T_J = 25\text{ °C}$		31	240	mV
		$V_I = 30\text{ to }36\text{ V}$		35	200	mV
		$V_I = 30\text{ to }36\text{ V}$, $T_J = 25\text{ °C}$		14	120	mV
		$V_I = 26.7\text{ to }38\text{ V}$, $T_J = 25\text{ °C}$		31	240	mV
$\Delta V_O^{(1)}$	Load regulation	$I_O = 5\text{ mA to }1\text{ A}$		25	100	mV
		$I_O = 5\text{ mA to }1.5\text{ A}$, $T_J = 25\text{ °C}$		30	100	
		$I_O = 250\text{ to }750\text{ mA}$		10	50	
I_q	Quiescent current	$T_J = 25\text{ °C}$		4.6	6	mA
					6	mA
ΔI_q	Quiescent current change	$V_I = 27.3\text{ to }38\text{ V}$, $I_O = 500\text{ mA}$			0.8	mA
		$V_I = 27.3\text{ to }38\text{ V}$, $T_J = 25\text{ °C}$			0.8	mA
		$I_O = 5\text{ mA to }1\text{ A}$			0.5	mA
SVR	Supply voltage rejection	$V_I = 28\text{ to }38\text{ V}$, $f = 120\text{ Hz}$, $I_O = 500\text{ mA}$		54		dB
V_d	Dropout voltage	$I_O = 1\text{ A}$, $T_J = 25\text{ °C}$		2		V
eN	Output noise voltage	$T_A = 25\text{ °C}$, $B = 10\text{ Hz to }100\text{ kHz}$		10		$\mu\text{V}/V_O$
R_O	Output resistance	$f = 1\text{ kHz}$		20		m
I_{sc}	Short circuit current	$V_I = 35\text{ V}$, $T_A = 25\text{ °C}$		0.2		A
I_{scp}	Short circuit peak current	$T_J = 25\text{ °C}$		2.2		A
$\Delta V_O/\Delta T$	Output voltage drift			-1.5		$\text{mV}/\text{°C}$

1. Load and line regulation are specified at constant junction temperature. Changes in V_O due to heating effects must be taken into account separately. Pulse testing with low duty cycle is used.

Note: Minimum load current for regulation is 5 mA.

Refer to the test circuits, $T_J = 0$ to 125 °C, $V_I = 10$ V, $I_O = 500$ mA, $C_I = 0.33$ μ F, $C_O = 0.1$ μ F unless otherwise specified.

Table 10. Electrical characteristics of L7805C

Symbol	Parameter	Test conditions	Min.	Typ.	Max.	Unit
V_O	Output voltage	$T_J = 25$ °C	4.8	5	5.2	V
V_O	Output voltage	$I_O = 5$ mA to 1 A, $V_I = 7$ to 18 V	4.75	5	5.25	V
V_O	Output voltage	$I_O = 1$ A, $V_I = 18$ to 20V, $T_J = 25$ °C	4.75	5	5.25	V
ΔV_O ⁽¹⁾	Line regulation	$V_I = 7$ to 25 V, $T_J = 25$ °C		3	100	mV
		$V_I = 8$ to 12 V, $T_J = 25$ °C		1	50	
ΔV_O ⁽¹⁾	Load regulation	$I_O = 5$ mA to 1.5 A, $T_J = 25$ °C			100	mV
		$I_O = 250$ to 750 mA, $T_J = 25$ °C			50	
I_d	Quiescent current	$T_J = 25$ °C			8	mA
ΔI_d	Quiescent current change	$I_O = 5$ mA to 1 A			0.5	mA
		$V_I = 7$ to 23 V			0.8	
$\Delta V_O/\Delta T$	Output voltage drift	$I_O = 5$ mA		-1.1		mV/°C
eN	Output noise voltage	$B = 10$ Hz to 100 kHz, $T_J = 25$ °C		40		μ V/ V_O
SVR	Supply voltage rejection	$V_I = 8$ to 18 V, $f = 120$ Hz	62			dB
V_d	Dropout voltage	$I_O = 1$ A, $T_J = 25$ °C		2		V
R_O	Output resistance	$f = 1$ kHz		17		m Ω
I_{sc}	Short circuit current	$V_I = 35$ V, $T_J = 25$ °C		0.75		A
I_{scp}	Short circuit peak current	$T_J = 25$ °C		2.2		A

1. Load and line regulation are specified at constant junction temperature. Changes in V_O due to heating effects must be taken into account separately. Pulse testing with low duty cycle is used.

Note: Minimum load current for regulation is 5 mA.

Refer to the test circuits, $T_J = 0$ to 125 °C, $V_I = 11$ V, $I_O = 500$ mA, $C_I = 0.33$ μ F, $C_O = 0.1$ μ F unless otherwise specified.

Table 11. Electrical characteristics of L7806C

Symbol	Parameter	Test conditions	Min.	Typ.	Max.	Unit
V_O	Output voltage	$T_J = 25$ °C	5.75	6	6.25	V
V_O	Output voltage	$I_O = 5$ mA to 1 A, $V_I = 8$ to 19 V	5.7	6	6.3	V
V_O	Output voltage	$I_O = 1$ A, $V_I = 19$ to 21 V, $T_J = 25$ °C	5.7	6	6.3	V
ΔV_O ⁽¹⁾	Line regulation	$V_I = 8$ to 25 V, $T_J = 25$ °C			120	mV
		$V_I = 9$ to 13 V, $T_J = 25$ °C			60	
ΔV_O ⁽¹⁾	Load regulation	$I_O = 5$ mA to 1.5 A, $T_J = 25$ °C			120	mV
		$I_O = 250$ to 750 mA, $T_J = 25$ °C			60	
I_d	Quiescent current	$T_J = 25$ °C			8	mA
DI_d	Quiescent current change	$I_O = 5$ mA to 1 A			0.5	mA
		$V_I = 8$ to 24 V			1.3	
$\Delta V_O/\Delta T$	Output voltage drift	$I_O = 5$ mA		-0.8		mV/°C
eN	Output noise voltage	$B = 10$ Hz to 100 kHz, $T_J = 25$ °C		45		μ V/ V_O
SVR	Supply voltage rejection	$V_I = 9$ to 19 V, $f = 120$ Hz	59			dB
V_d	Dropout voltage	$I_O = 1$ A, $T_J = 25$ °C		2		V
R_O	Output resistance	$f = 1$ kHz		19		m Ω
I_{sc}	Short circuit current	$V_I = 35$ V, $T_J = 25$ °C		0.55		A
I_{scp}	Short circuit peak current	$T_J = 25$ °C		2.2		A

1. Load and line regulation are specified at constant junction temperature. Changes in V_O due to heating effects must be taken into account separately. Pulse testing with low duty cycle is used.

Note: Minimum load current for regulation is 5 mA.

Refer to the test circuits, $T_J = 0$ to 125 °C, $V_I = 14$ V, $I_O = 500$ mA, $C_I = 0.33$ μ F, $C_O = 0.1$ μ F unless otherwise specified.

Table 12. Electrical characteristics of L7808C

Symbol	Parameter	Test conditions	Min.	Typ.	Max.	Unit
V_O	Output voltage	$T_J = 25$ °C	7.7	8	8.3	V
V_O	Output voltage	$I_O = 5$ mA to 1 A, $V_I = 10.5$ to 21 V	7.6	8	8.4	V
V_O	Output voltage	$I_O = 1$ A, $V_I = 21$ to 25 V, $T_J = 25$ °C	7.6	8	8.4	V
ΔV_O ⁽¹⁾	Line regulation	$V_I = 10.5$ to 25 V, $T_J = 25$ °C			160	mV
		$V_I = 11$ to 17 V, $T_J = 25$ °C			80	
ΔV_O ⁽¹⁾	Load regulation	$I_O = 5$ mA to 1.5 A, $T_J = 25$ °C			160	mV
		$I_O = 250$ to 750 mA, $T_J = 25$ °C			80	
I_d	Quiescent current	$T_J = 25$ °C			8	mA
ΔI_d	Quiescent current change	$I_O = 5$ mA to 1 A			0.5	mA
		$V_I = 10.5$ to 25 V			1	
$\Delta V_O/\Delta T$	Output voltage drift	$I_O = 5$ mA		-0.8		mV/°C
eN	Output noise voltage	B = 10 Hz to 100 kHz, $T_J = 25$ °C		52		μ V/ V_O
SVR	Supply voltage rejection	$V_I = 11.5$ to 21.5 V, f = 120 Hz	56			dB
V_d	Dropout voltage	$I_O = 1$ A, $T_J = 25$ °C		2		V
R_O	Output resistance	f = 1 kHz		16		m Ω
I_{sc}	Short circuit current	$V_I = 35$ V, $T_J = 25$ °C		0.45		A
I_{scp}	Short circuit peak current	$T_J = 25$ °C		2.2		A

1. Load and line regulation are specified at constant junction temperature. Changes in V_O due to heating effects must be taken into account separately. Pulse testing with low duty cycle is used.

Note: Minimum load current for regulation is 5 mA.

Refer to the test circuits, $T_J = 0$ to 125 °C, $V_I = 14.5$ V, $I_O = 500$ mA, $C_I = 0.33$ μ F, $C_O = 0.1$ μ F unless otherwise specified.

Table 13. Electrical characteristics of L7885C

Symbol	Parameter	Test conditions	Min.	Typ.	Max.	Unit
V_O	Output voltage	$T_J = 25$ °C	8.2	8.5	8.8	V
V_O	Output voltage	$I_O = 5$ mA to 1 A, $V_I = 11$ to 21.5 V	8.1	8.5	8.9	V
V_O	Output voltage	$I_O = 1$ A, $V_I = 21.5$ to 26 V, $T_J = 25$ °C	8.1	8.5	8.9	V
ΔV_O ⁽¹⁾	Line regulation	$V_I = 11$ to 27 V, $T_J = 25$ °C			160	mV
		$V_I = 11.5$ to 17.5 V, $T_J = 25$ °C			80	
ΔV_O ⁽¹⁾	Load regulation	$I_O = 5$ mA to 1.5 A, $T_J = 25$ °C			160	mV
		$I_O = 250$ to 750 mA, $T_J = 25$ °C			80	
I_d	Quiescent current	$T_J = 25$ °C			8	mA
ΔI_d	Quiescent current change	$I_O = 5$ mA to 1 A			0.5	mA
		$V_I = 11$ to 26 V			1	
$\Delta V_O/\Delta T$	Output voltage drift	$I_O = 5$ mA		-0.8		mV/°C
eN	Output noise voltage	$B = 10$ Hz to 100 kHz, $T_J = 25$ °C		55		μ V/ V_O
SVR	Supply voltage rejection	$V_I = 12$ to 22 V, $f = 120$ Hz	56			dB
V_d	Dropout voltage	$I_O = 1$ A, $T_J = 25$ °C		2		V
R_O	Output resistance	$f = 1$ kHz		16		m Ω
I_{sc}	Short circuit current	$V_I = 35$ V, $T_J = 25$ °C		0.45		A
I_{scp}	Short circuit peak current	$T_J = 25$ °C		2.2		A

1. Load and line regulation are specified at constant junction temperature. Changes in V_O due to heating effects must be taken into account separately. Pulse testing with low duty cycle is used.

Note: Minimum load current for regulation is 5 mA.

Refer to the test circuits, $T_J = 0$ to 125 °C, $V_I = 15$ V, $I_O = 500$ mA, $C_I = 0.33$ μ F, $C_O = 0.1$ μ F unless otherwise specified.

Table 14. Electrical characteristics of L7809C

Symbol	Parameter	Test conditions	Min.	Typ.	Max.	Unit
V_O	Output voltage	$T_J = 25$ °C	8.64	9	9.36	V
V_O	Output voltage	$I_O = 5$ mA to 1 A, $V_I = 11.5$ to 22 V	8.55	9	9.45	V
V_O	Output voltage	$I_O = 1$ A, $V_I = 22$ to 26 V, $T_J = 25$ °C	8.55	9	9.45	V
ΔV_O ⁽¹⁾	Line regulation	$V_I = 11.5$ to 26 V, $T_J = 25$ °C			180	mV
		$V_I = 12$ to 18 V, $T_J = 25$ °C			90	
ΔV_O ⁽¹⁾	Load regulation	$I_O = 5$ mA to 1.5 A, $T_J = 25$ °C			180	mV
		$I_O = 250$ to 750 mA, $T_J = 25$ °C			90	
I_d	Quiescent current	$T_J = 25$ °C			8	mA
ΔI_d	Quiescent current change	$I_O = 5$ mA to 1 A			0.5	mA
		$V_I = 11.5$ to 26 V			1	
$\Delta V_O/\Delta T$	Output voltage drift	$I_O = 5$ mA		-1		mV/°C
eN	Output noise voltage	B = 10 Hz to 100 kHz, $T_J = 25$ °C		70		μ V/ V_O
SVR	Supply voltage rejection	$V_I = 12$ to 23 V, f = 120 Hz	55			dB
V_d	Dropout voltage	$I_O = 1$ A, $T_J = 25$ °C		2		V
R_O	Output resistance	f = 1 kHz		17		m Ω
I_{sc}	Short circuit current	$V_I = 35$ V, $T_J = 25$ °C		0.40		A
I_{scp}	Short circuit peak current	$T_J = 25$ °C		2.2		A

1. Load and line regulation are specified at constant junction temperature. Changes in V_O due to heating effects must be taken into account separately. Pulse testing with low duty cycle is used.

Note: Minimum load current for regulation is 5 mA.

Refer to the test circuits, $T_J = 0$ to 125 °C, $V_I = 19$ V, $I_O = 500$ mA, $C_I = 0.33$ μ F, $C_O = 0.1$ μ F unless otherwise specified.

Table 15. Electrical characteristics of L7812C

Symbol	Parameter	Test conditions	Min.	Typ.	Max.	Unit
V_O	Output voltage	$T_J = 25$ °C	11.5	12	12.5	V
V_O	Output voltage	$I_O = 5$ mA to 1 A, $V_I = 14.5$ to 25 V	11.4	12	12.6	V
V_O	Output voltage	$I_O = 1$ A, $V_I = 25$ to 27 V, $T_J = 25$ °C	11.4	12	12.6	V
ΔV_O ⁽¹⁾	Line regulation	$V_I = 14.5$ to 30 V, $T_J = 25$ °C			240	mV
		$V_I = 16$ to 22 V, $T_J = 25$ °C			120	
ΔV_O ⁽¹⁾	Load regulation	$I_O = 5$ mA to 1.5 A, $T_J = 25$ °C			240	mV
		$I_O = 250$ to 750 mA, $T_J = 25$ °C			120	
I_d	Quiescent current	$T_J = 25$ °C			8	mA
ΔI_d	Quiescent current change	$I_O = 5$ mA to 1 A			0.5	mA
		$V_I = 14.5$ to 30 V			1	
$\Delta V_O/\Delta T$	Output voltage drift	$I_O = 5$ mA		-1		mV/°C
eN	Output noise voltage	$B = 10$ Hz to 100 kHz, $T_J = 25$ °C		75		μ V/ V_O
SVR	Supply voltage rejection	$V_I = 15$ to 25 V, $f = 120$ Hz	55			dB
V_d	Dropout voltage	$I_O = 1$ A, $T_J = 25$ °C		2		V
R_O	Output resistance	$f = 1$ kHz		18		m Ω
I_{sc}	Short circuit current	$V_I = 35$ V, $T_J = 25$ °C		0.35		A
I_{scp}	Short circuit peak current	$T_J = 25$ °C		2.2		A

1. Load and line regulation are specified at constant junction temperature. Changes in V_O due to heating effects must be taken into account separately. Pulse testing with low duty cycle is used.

Note: Minimum load current for regulation is 5 mA.

Refer to the test circuits, $T_J = 0$ to 125 °C, $V_I = 23$ V, $I_O = 500$ mA, $C_I = 0.33$ μ F, $C_O = 0.1$ μ F unless otherwise specified.

Table 16. Electrical characteristics of L7815C

Symbol	Parameter	Test conditions	Min.	Typ.	Max.	Unit
V_O	Output voltage	$T_J = 25$ °C	14.4	15	15.6	V
V_O	Output voltage	$I_O = 5$ mA to 1 A, $V_I = 17.5$ to 28 V	14.25	15	15.75	V
V_O	Output voltage	$I_O = 1$ A, $V_I = 28$ to 30 V, $T_J = 25$ °C	14.25	15	15.75	V
ΔV_O ⁽¹⁾	Line regulation	$V_I = 17.5$ to 30 V, $T_J = 25$ °C			300	mV
		$V_I = 20$ to 26 V, $T_J = 25$ °C			150	
ΔV_O ⁽¹⁾	Load regulation	$I_O = 5$ mA to 1.5 A, $T_J = 25$ °C			300	mV
		$I_O = 250$ to 750 mA, $T_J = 25$ °C			150	
I_d	Quiescent current	$T_J = 25$ °C			8	mA
ΔI_d	Quiescent current change	$I_O = 5$ mA to 1A			0.5	mA
		$V_I = 17.5$ to 30 V			1	
$\Delta V_O/\Delta T$	Output voltage drift	$I_O = 5$ mA		-1		mV/°C
eN	Output noise voltage	B = 10 Hz to 100kHz, $T_J = 25$ °C		90		μ V/ V_O
SVR	Supply voltage rejection	$V_I = 18.5$ to 28.5 V, $f = 120$ Hz	54			dB
V_d	Dropout voltage	$I_O = 1$ A, $T_J = 25$ °C		2		V
R_O	Output resistance	$f = 1$ kHz		19		m Ω
I_{sc}	Short circuit current	$V_I = 35$ V, $T_J = 25$ °C		0.23		A
I_{scp}	Short circuit peak current	$T_J = 25$ °C		2.2		A

1. Load and line regulation are specified at constant junction temperature. Changes in V_O due to heating effects must be taken into account separately. Pulse testing with low duty cycle is used.

Note: Minimum load current for regulation is 5 mA.

Refer to the test circuits, $T_J = 0$ to 125 °C, $V_I = 26$ V, $I_O = 500$ mA, $C_I = 0.33$ μ F, $C_O = 0.1$ μ F unless otherwise specified.

Table 17. Electrical characteristics of L7818C

Symbol	Parameter	Test conditions	Min.	Typ.	Max.	Unit
V_O	Output voltage	$T_J = 25$ °C	17.3	18	18.7	V
V_O	Output voltage	$I_O = 5$ mA to 1 A, $V_I = 21$ to 31 V	17.1	18	18.9	V
V_O	Output voltage	$I_O = 1$ A, $V_I = 31$ to 33 V, $T_J = 25$ °C	17.1	18	18.9	V
ΔV_O ⁽¹⁾	Line regulation	$V_I = 21$ to 33 V, $T_J = 25$ °C			360	mV
		$V_I = 24$ to 30 V, $T_J = 25$ °C			180	
ΔV_O ⁽¹⁾	Load regulation	$I_O = 5$ mA to 1.5 A, $T_J = 25$ °C			360	mV
		$I_O = 250$ to 750 mA, $T_J = 25$ °C			180	
I_d	Quiescent current	$T_J = 25$ °C			8	mA
ΔI_d	Quiescent current change	$I_O = 5$ mA to 1 A			0.5	mA
		$V_I = 21$ to 33 V			1	
$\Delta V_O/\Delta T$	Output voltage drift	$I_O = 5$ mA		-1		mV/°C
eN	Output noise voltage	$B = 10$ Hz to 100 kHz, $T_J = 25$ °C		110		μ V/ V_O
SVR	Supply voltage rejection	$V_I = 22$ to 32 V, $f = 120$ Hz	53			dB
V_d	Dropout voltage	$I_O = 1$ A, $T_J = 25$ °C		2		V
R_O	Output resistance	$f = 1$ kHz		22		m Ω
I_{sc}	Short circuit current	$V_I = 35$ V, $T_J = 25$ °C		0.20		A
I_{scp}	Short circuit peak current	$T_J = 25$ °C		2.1		A

1. Load and line regulation are specified at constant junction temperature. Changes in V_O due to heating effects must be taken into account separately. Pulse testing with low duty cycle is used.

Note: Minimum load current for regulation is 5 mA.

Refer to the test circuits, $T_J = 0$ to 125 °C, $V_I = 33$ V, $I_O = 500$ mA, $C_I = 0.33$ μ F, $C_O = 0.1$ μ F unless otherwise specified.

Table 18. Electrical characteristics of L7824C

Symbol	Parameter	Test conditions	Min.	Typ.	Max.	Unit
V_O	Output voltage	$T_J = 25$ °C	23	24	25	V
V_O	Output voltage	$I_O = 5$ mA to 1 A, $V_I = 27$ to 37 V	22.8	24	25.2	V
V_O	Output voltage	$I_O = 1$ A, $V_I = 37$ to 38 V, $T_J = 25$ °C	22.8	24	25.2	V
ΔV_O ⁽¹⁾	Line regulation	$V_I = 27$ to 38 V, $T_J = 25$ °C			480	mV
		$V_I = 30$ to 36 V, $T_J = 25$ °C			240	
ΔV_O ⁽¹⁾	Load regulation	$I_O = 5$ mA to 1.5 A, $T_J = 25$ °C			480	mV
		$I_O = 250$ to 750 mA, $T_J = 25$ °C			240	
I_d	Quiescent current	$T_J = 25$ °C			8	mA
ΔI_d	Quiescent current change	$I_O = 5$ mA to 1 A			0.5	mA
		$V_I = 27$ to 38 V			1	
$\Delta V_O/\Delta T$	Output voltage drift	$I_O = 5$ mA		-1.5		mV/°C
eN	Output noise voltage	$B = 10$ Hz to 100 kHz, $T_J = 25$ °C		170		μ V/ V_O
SVR	Supply voltage rejection	$V_I = 28$ to 38 V, $f = 120$ Hz	50			dB
V_d	Dropout voltage	$I_O = 1$ A, $T_J = 25$ °C		2		V
R_O	Output resistance	$f = 1$ kHz		28		m Ω
I_{sc}	Short circuit current	$V_I = 35$ V, $T_J = 25$ °C		0.15		A
I_{scp}	Short circuit peak current	$T_J = 25$ °C		2.1		A

1. Load and line regulation are specified at constant junction temperature. Changes in V_O due to heating effects must be taken into account separately. Pulse testing with low duty cycle is used.

Note: Minimum load current for regulation is 5 mA.

6 Application information

6.1 Design consideration

The L78 Series of fixed voltage regulators are designed with thermal overload protection that shuts down the circuit when subjected to an excessive power overload condition, internal short-circuit protection that limits the maximum current the circuit will pass, and output transistor safe-area compensation that reduces the output short-circuit current as the voltage across the pass transistor is increased. In many low current applications, compensation capacitors are not required. However, it is recommended that the regulator input be bypassed with capacitor if the regulator is connected to the power supply filter with long lengths, or if the output load capacitance is large. An input bypass capacitor should be selected to provide good high frequency characteristics to insure stable operation under all load conditions. A 0.33 μF or larger tantalum, mylar or other capacitor having low internal impedance at high frequencies should be chosen. The bypass capacitor should be mounted with the shortest possible leads directly across the regulators input terminals. Normally good construction techniques should be used to minimize ground loops and lead resistance drops since the regulator has no external sense lead.

The addition of an operational amplifier allows adjustment to higher or intermediate values while retaining regulation characteristics. The minimum voltage obtained with the arrangement is 2 V greater than the regulator voltage.

The circuit of [Figure 14. High current voltage regulator](#) can be modified to provide supply protection against short circuit by adding a short circuit sense resistor, RSC, and an additional PNP transistor. The current sensing PNP must be able to handle the short circuit current of the three terminal regulator Therefore a four ampere plastic power transistor is specified.

Figure 9. Fixed output regulator

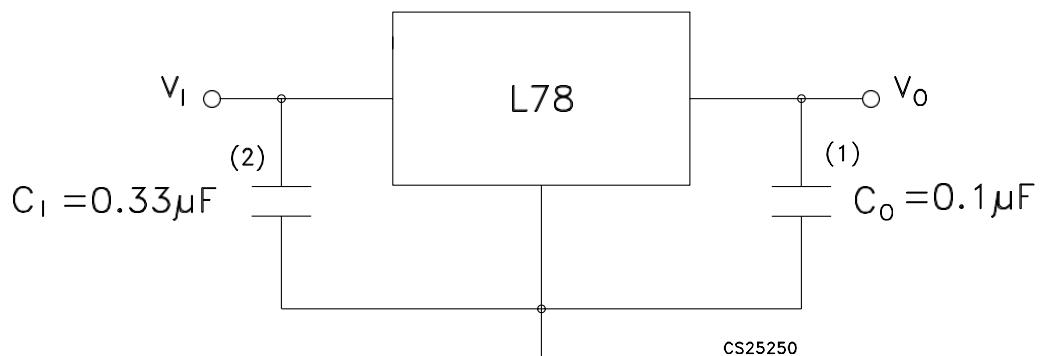

GAMG220920161007MT

1. Although no output capacitor is need for stability, it does improve transient response.
2. Required if regulator is located an appreciable distance from power supply filter.

Figure 10. Current regulator

Figure 11. Circuit for increasing output voltage

Figure 12. Adjustable output regulator (7 to 30 V)

Figure 13. 0.5 to 10 V regulator

Figure 14. High current voltage regulator

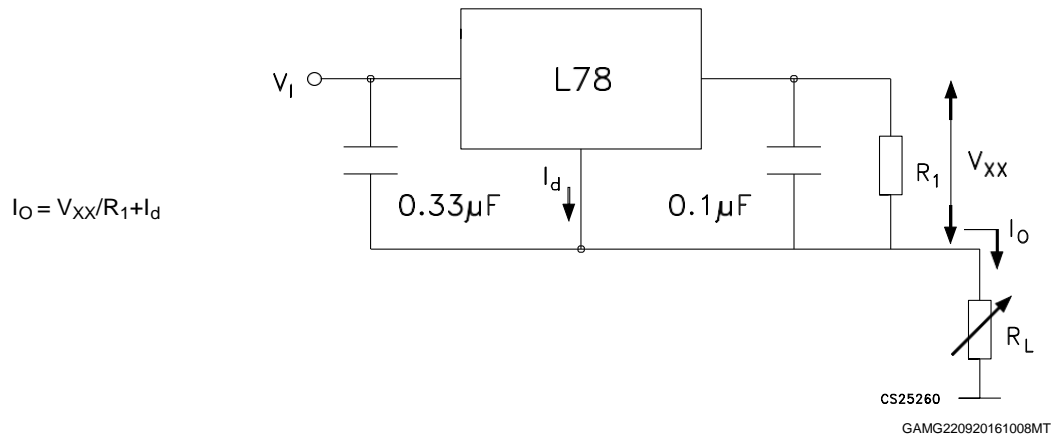
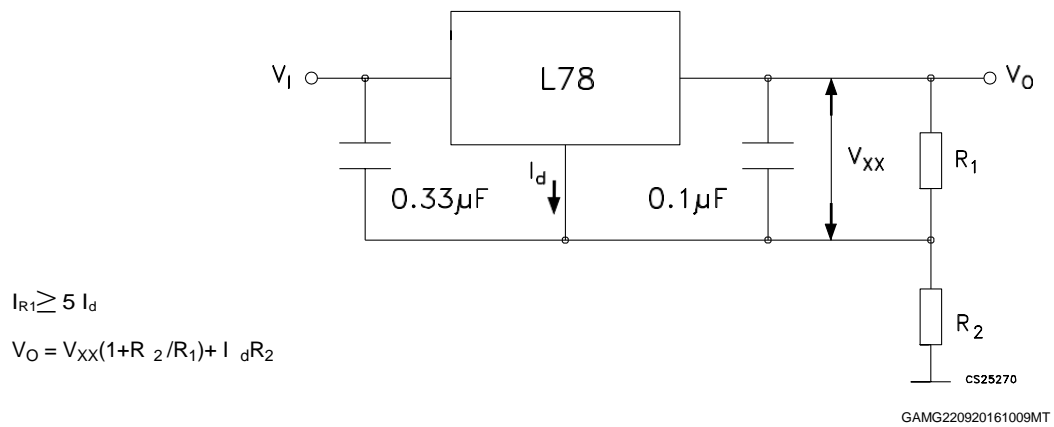
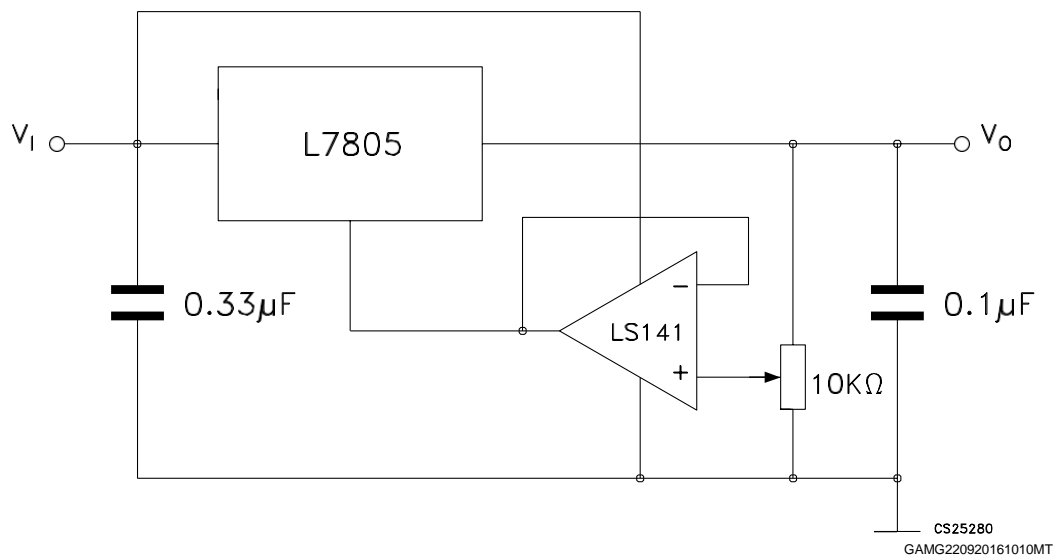
Figure 15. High output current with short circuit protection

Figure 16. Tracking voltage regulator

CS25320

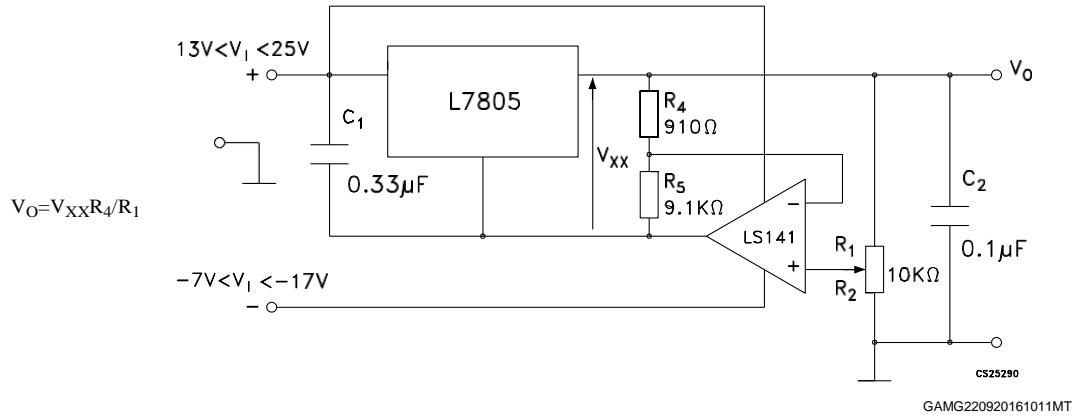
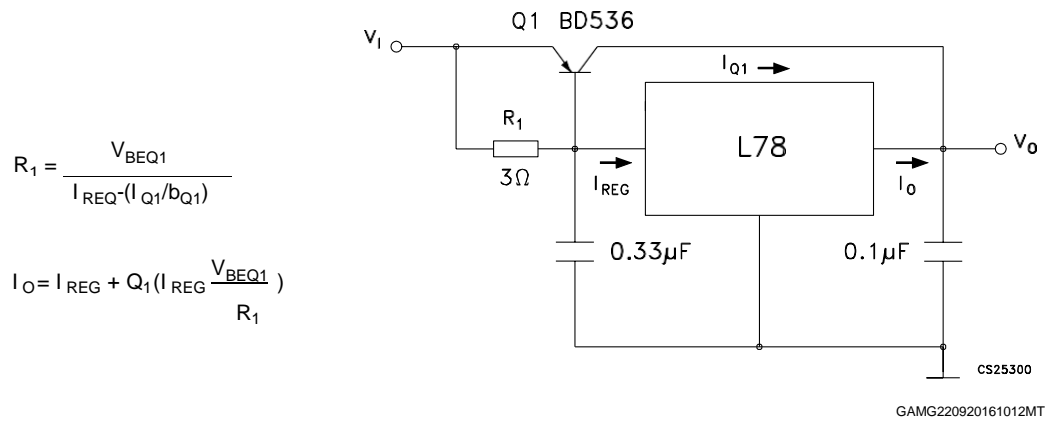
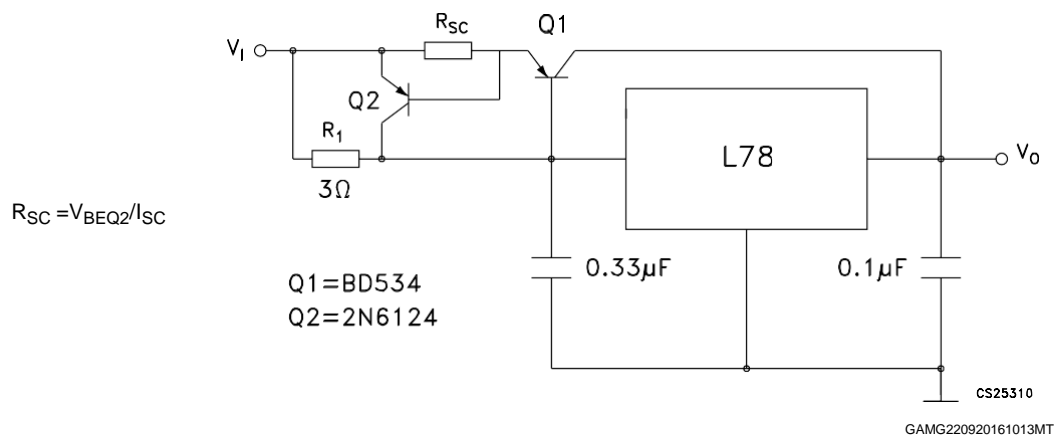
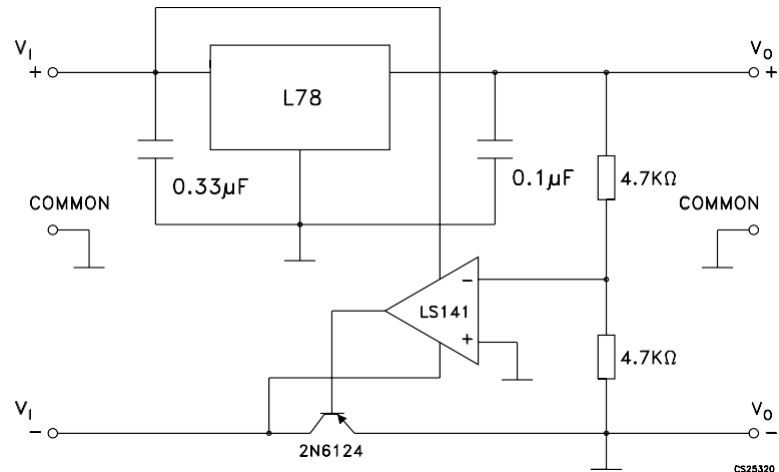
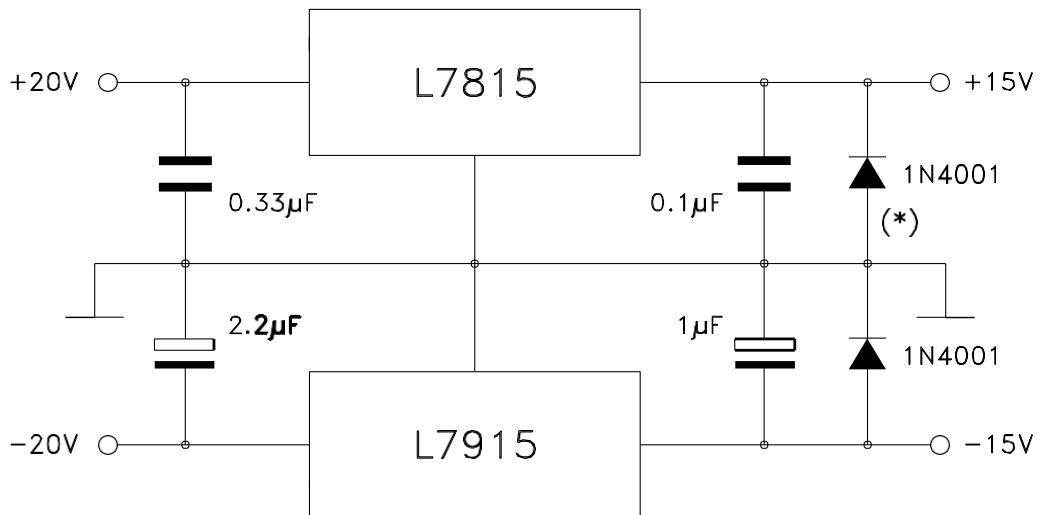
GAMG220920161014MT

Figure 17. Split power supply ($\pm 15\text{ V} - 1\text{ A}$)

CS25410

GAMG220920161015MT

Note: * Against potential latch-up problems.

Figure 18. Negative output voltage circuit

Figure 19. Switching regulator

Figure 20. High input voltage circuit (configuration 1)

Figure 21. High input voltage circuit (configuration 2)

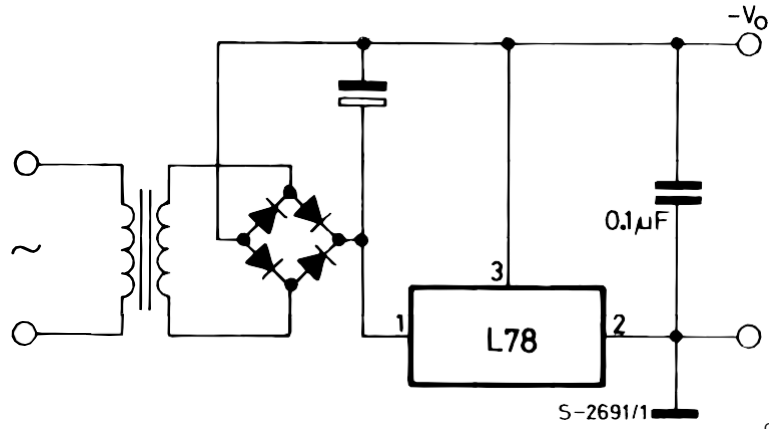
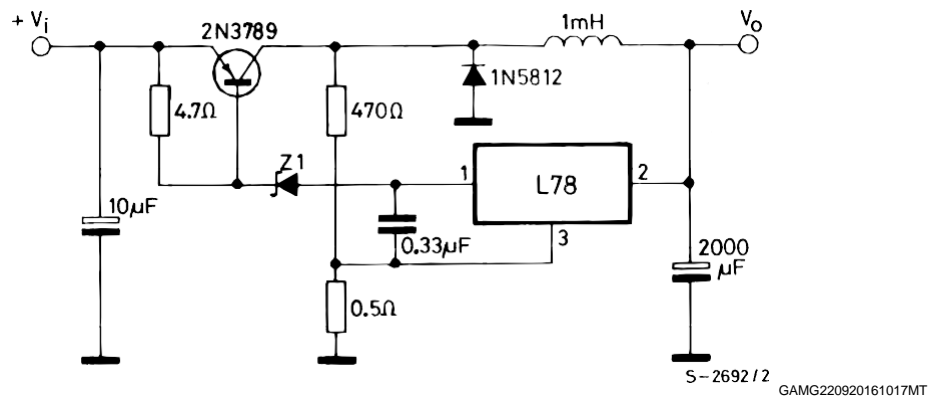
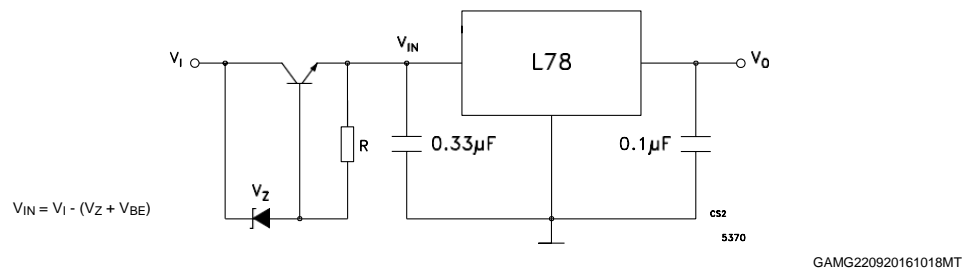
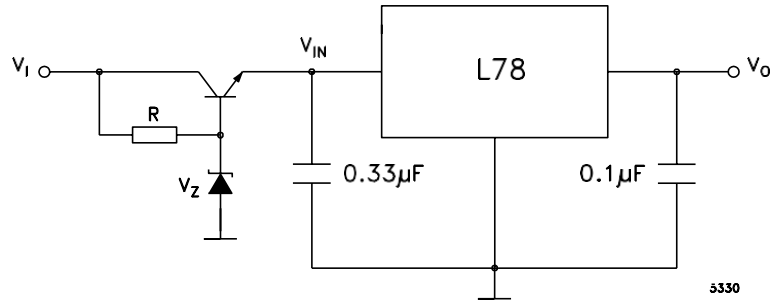
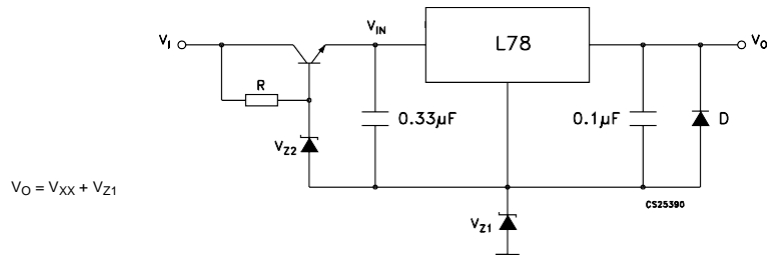

GAMG220920161019MT

Figure 22. High input and output voltage



$$V_O = V_{XX} + V_{Z1}$$

GAMG220920161020MT

Figure 23. Reducing power dissipation with dropping resistor

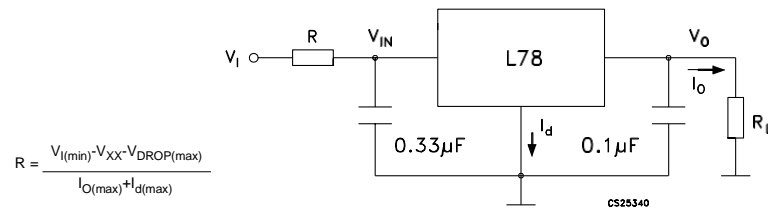

$$R = \frac{V_{I(\min)} - V_{XX} - V_{DROD(\max)}}{I_{O(\max)} + I_{d(\max)}}$$

GAMG220920161021MT

Figure 24. Remote shutdown

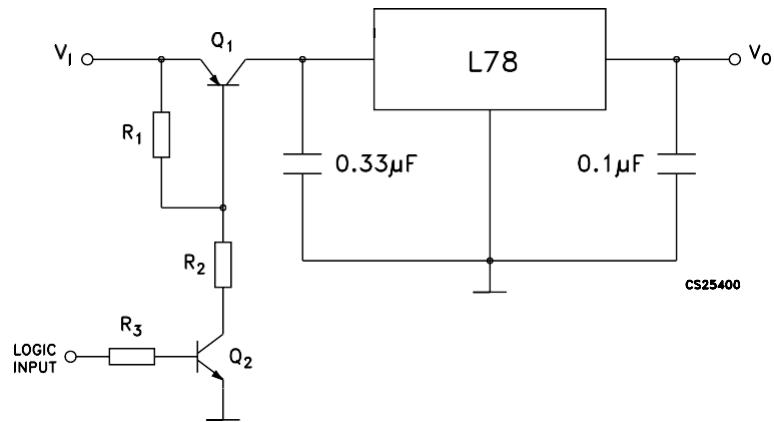

GAMG220920161022MT

Figure 25. Power AM modulator (unity voltage gain, $I_O \leq 0.5$)

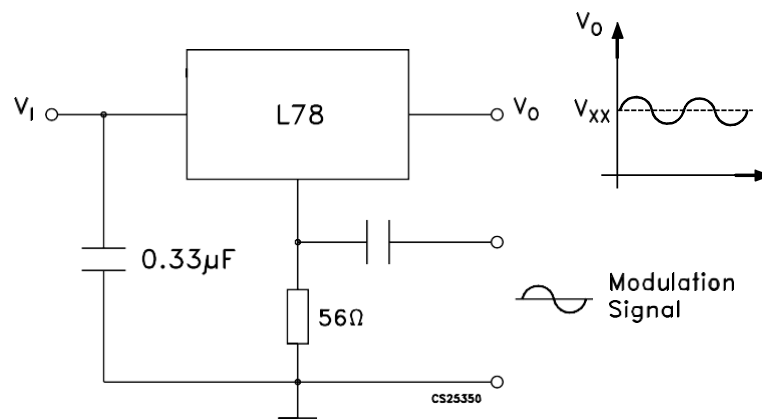

GAMG220920161023MT

Note: The circuit performs well up to 100 kHz.

Figure 26. Adjustable output voltage with temperature compensation

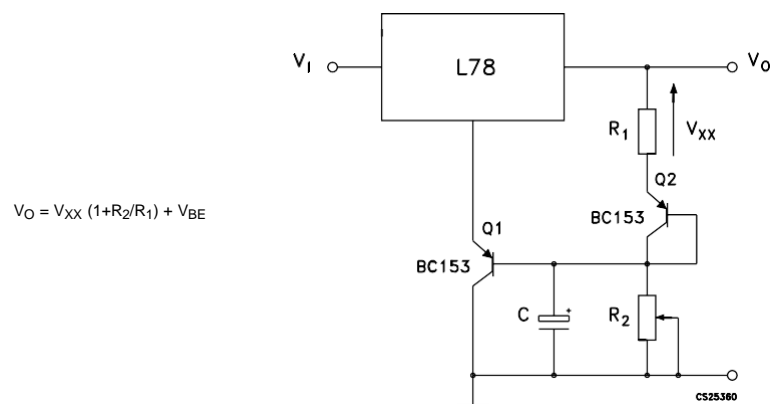

$$V_O = V_{XX} (1 + R_2/R_1) + V_{BE}$$

GAMG220920161024MT

Note: Q_2 is connected as a diode in order to compensate the variation of the Q_1 V_{BE} with the temperature. C allows a slow rise time of the V_O .

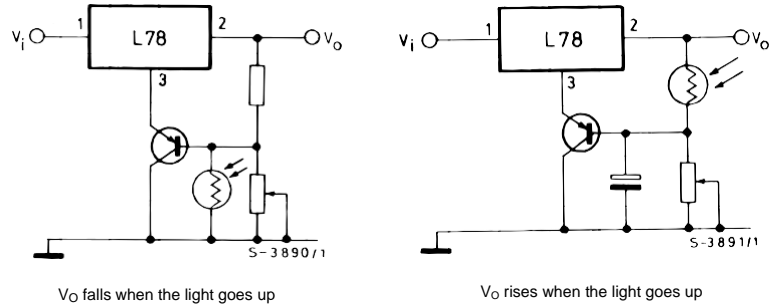
Figure 27. Light controllers ($V_{O(\min)} = V_{XX} + V_{BE}$)

GAMG220920161025MT

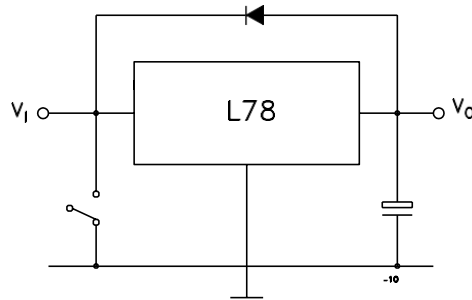
Figure 28. Protection against input short-circuit with high capacitance loads

GAMG220920161026MT

Note:

Application with high capacitance loads and an output voltage greater than 6 volts need an external diode (see [Figure 23. Reducing power dissipation with dropping resistor](#)) to protect the device against input short circuit. In this case the input voltage falls rapidly while the output voltage decrease slowly. The capacitance discharges by means of the base-emitter junction of the series pass transistor in the regulator. If the energy is sufficiently high, the transistor may be destroyed. The external diode by-passes the current from the IC to ground.

7 Typical performance

Figure 29. Dropout voltage vs junction temperature

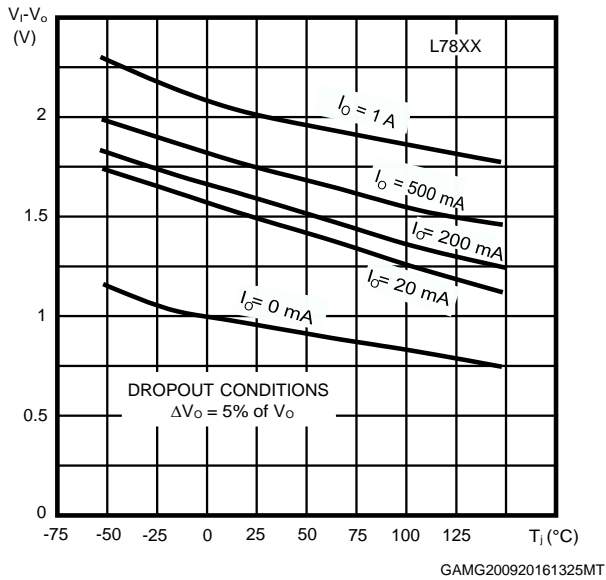

Figure 30. Peak output current vs input/output differential voltage

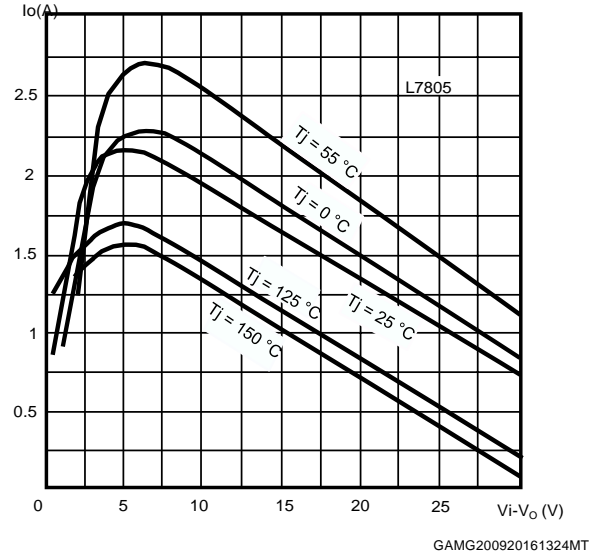

Figure 31. Supply voltage rejection vs frequency

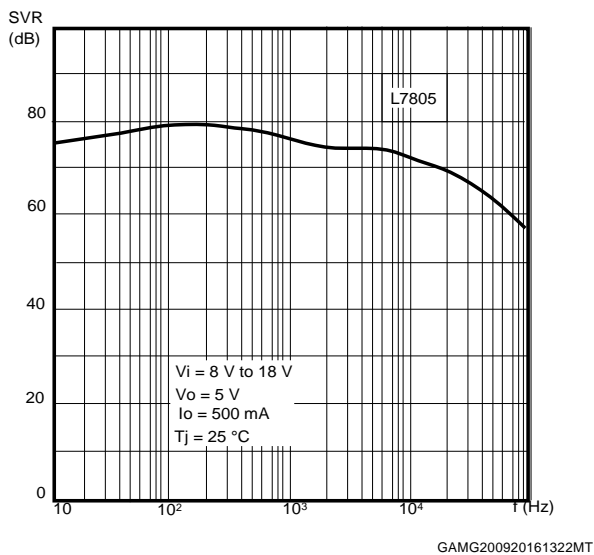

Figure 32. Output voltage vs junction temperature

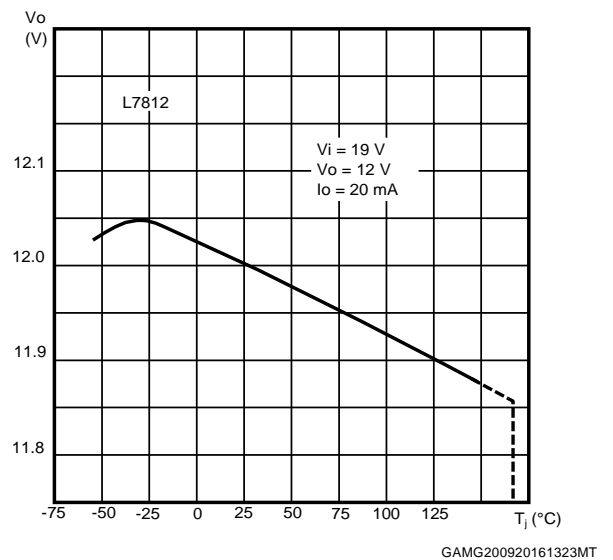
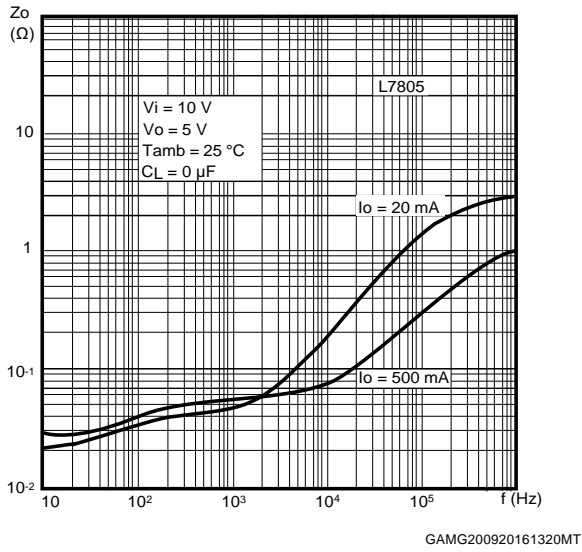
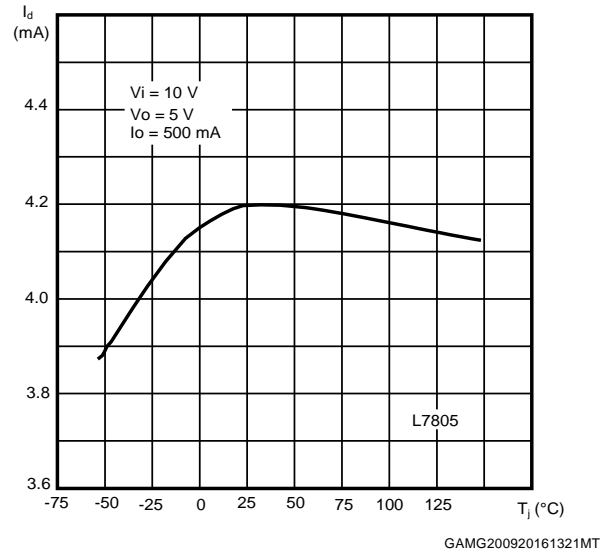
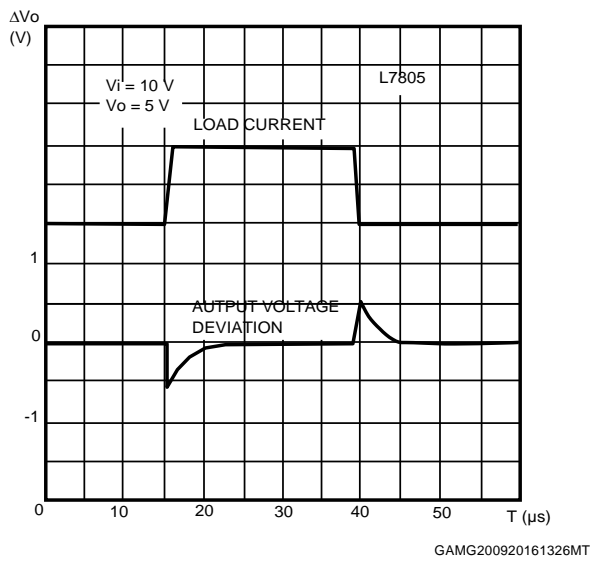
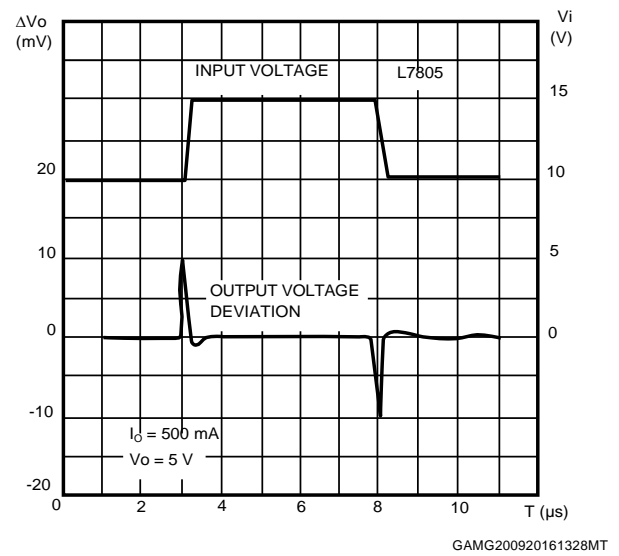
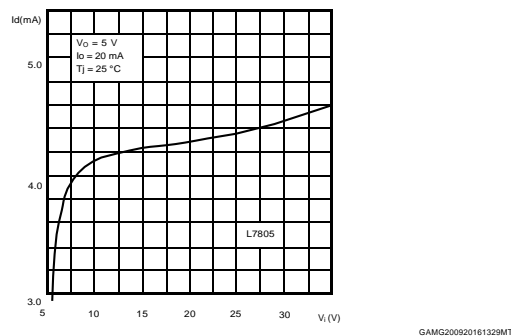

Figure 33. Output impedance vs frequency

Figure 34. Quiescent current vs junction temp.

Figure 35. Load transient response

Figure 36. Line transient response

Figure 37. Quiescent current vs. input voltage

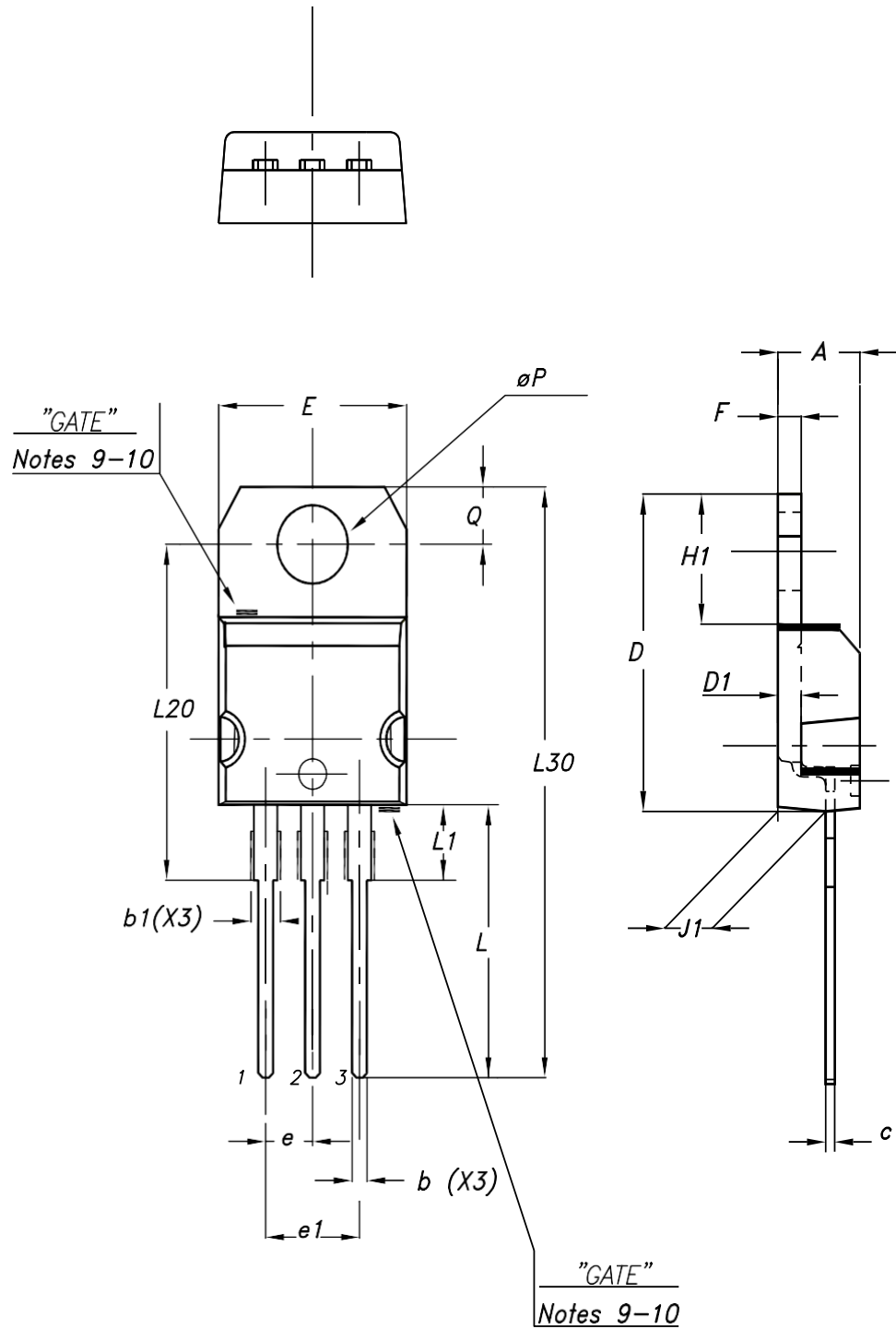
8 Package information

In order to meet environmental requirements, ST offers these devices in different grades of ECOPACK[®] packages, depending on their level of environmental compliance. ECOPACK[®] specifications, grade definitions and product status are available at: www.st.com. ECOPACK[®] is an ST trademark.

8.1 TO-220 (dual gauge) package information

Figure 38. TO-220 (dual gauge) package outline



0015988_21_Type A

Table 19. TO-220 (dual gauge) mechanical data

Dim.	mm		
	Min.	Typ.	Max.
A	4.40		4.60
b	0.61		0.88
b1	1.14		1.70
c	0.48		0.70
D	15.25		15.75
D1		1.27	
E	10		10.40
e	2.40		2.70
e1	4.95		5.15
F	1.23		1.32
H1	6.20		6.60
J1	2.40		2.72
L	13		14
L1	3.50		3.93
L20		16.40	
L30		28.90	
ØP	3.75		3.85
Q	2.65		2.95

8.2 TO-220 (single gauge) package information

Figure 39. TO-220 (single gauge) package outline

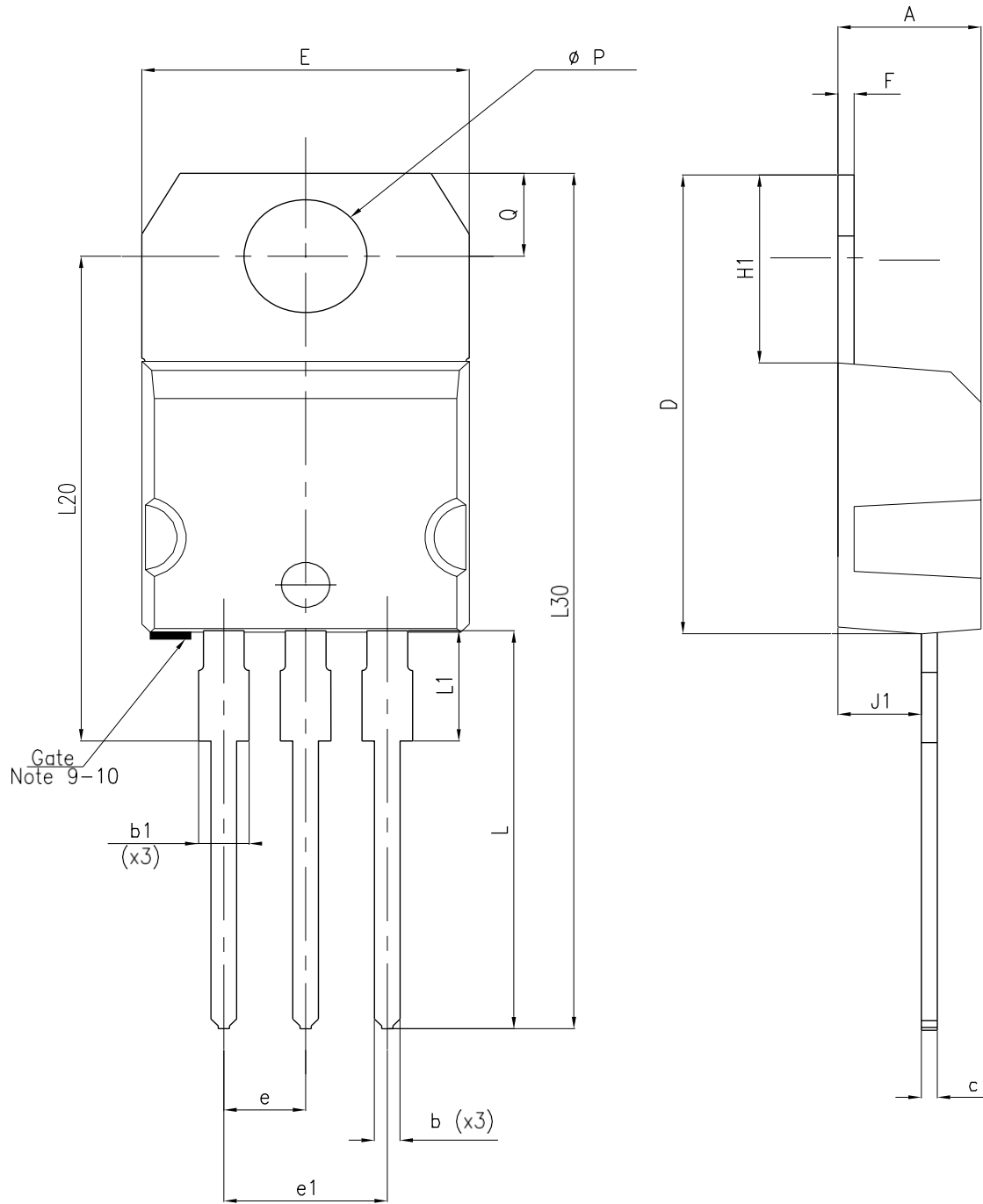

8174627_5

Table 20. TO-220 (single gauge) mechanical data

Dim.	mm		
	Min.	Typ.	Max.
A	4.40		4.60
b	0.61		0.88
b1	1.14		1.70
c	0.48		0.70
D	15.25		15.75
E	10.00		10.40
e	2.40		2.70
e1	4.95		5.15
F	0.51		0.60
H1	6.20		6.60
J1	2.40		2.72
L	13.00		14.00
L1	3.50		3.93
L20		16.40	
L30		28.90	
∅P	3.75		3.85
Q	2.65		2.95

8.3 TO-220FP type A package information

Figure 40. TO-220FP package outline

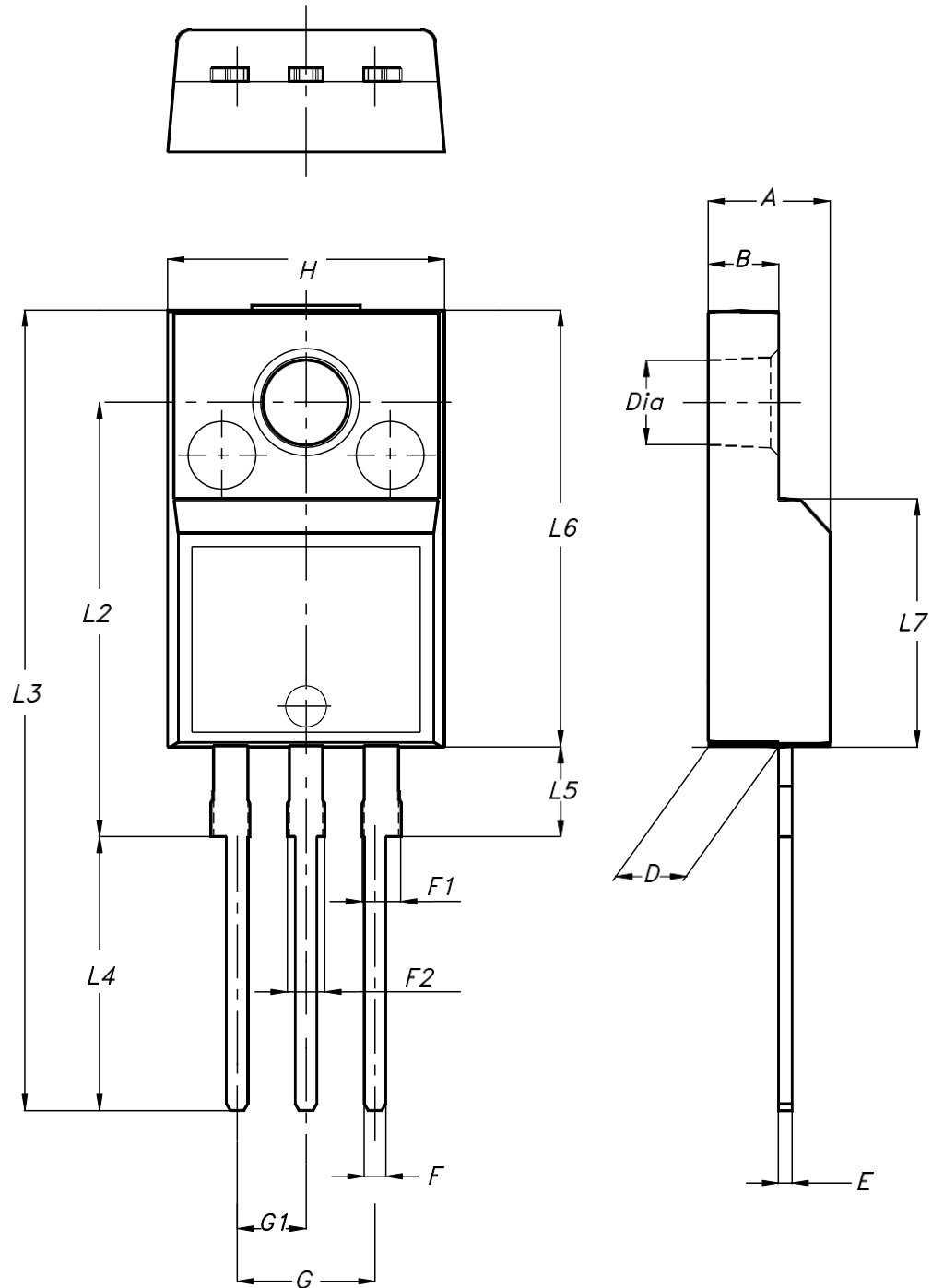

7012510_type_A

Figure 42. Tube for TO-220 (single gauge) (mm.)

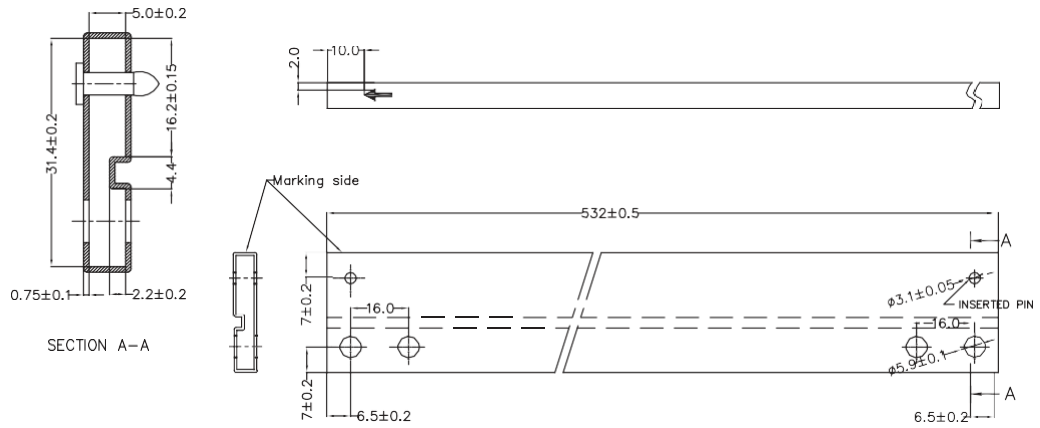

8.5 DPAK package information

Figure 43. DPAK package outline

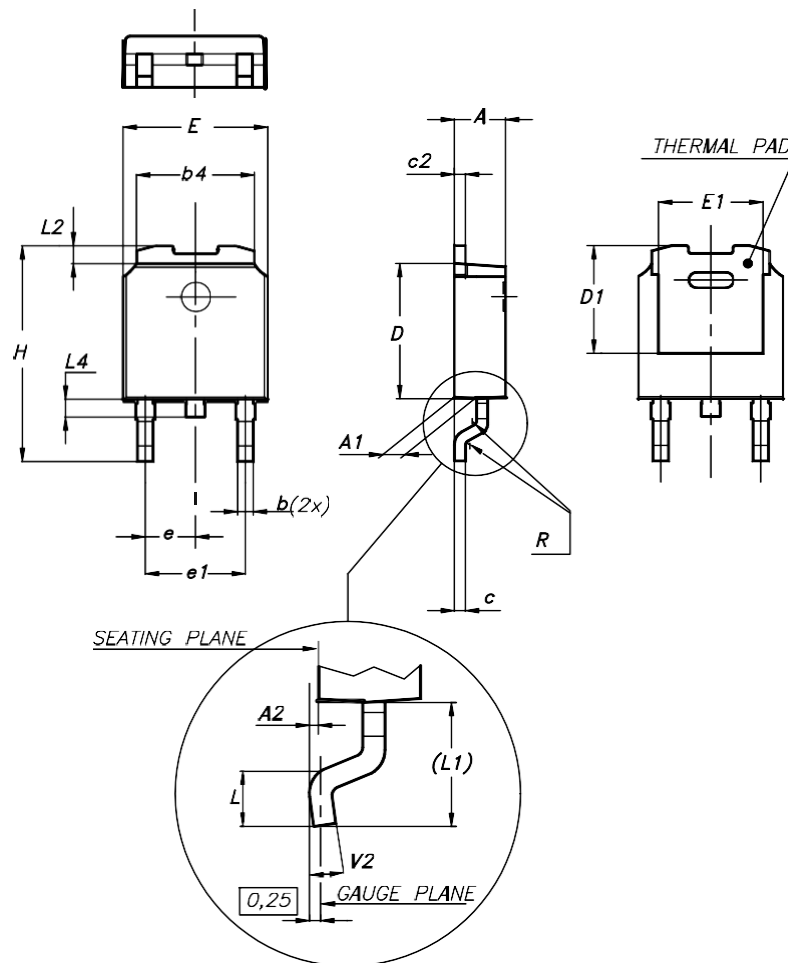

0068772_A_21

Table 22. DPAK mechanical data

Dim.	mm		
	Min.	Typ.	Max.
A	2.20		2.40
A1	0.90		1.10
A2	0.03		0.23
b	0.64		0.90
b4	5.20		5.40
c	0.45		0.60
c2	0.48		0.60
D	6.00		6.20
D1		5.10	
E	6.40		6.60
E1		4.70	
e		2.28	
e1	4.40		4.60
H	9.35		10.10
L	1.00		1.50
(L1)		2.80	
L2		0.80	
L4	0.60		1.00
R		0.20	
V2	0°		8°

Figure 44. DPAK recommended footprint (dimensions are in mm)

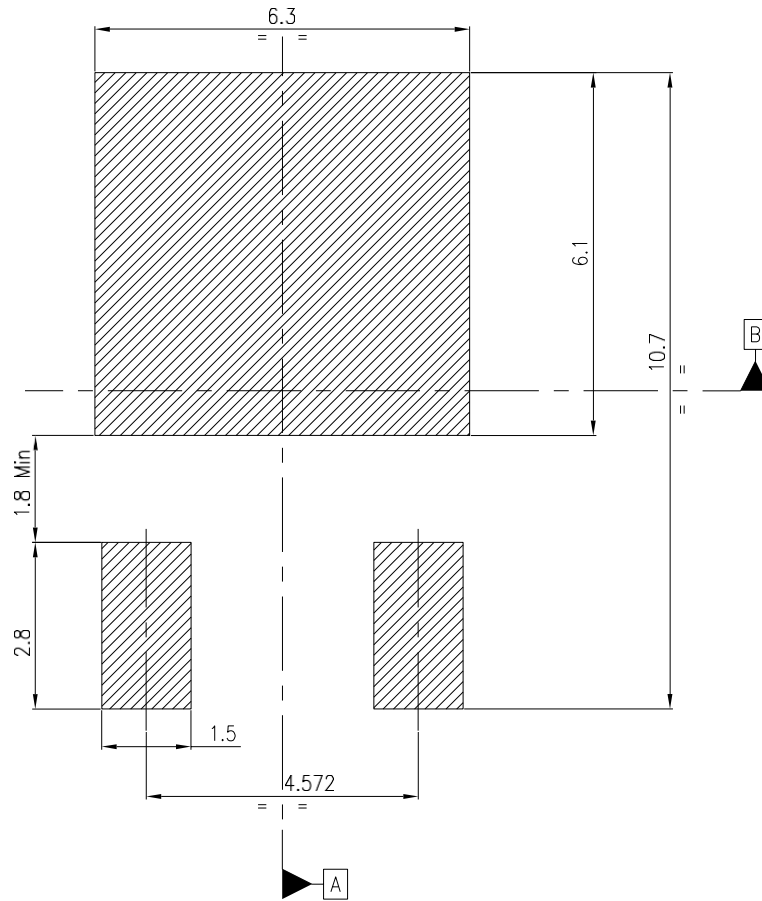

Footprint_0068772

8.6 D²PAK (SMD 2L STD-ST) type A package information

Figure 45. D²PAK (SMD 2L STD-ST) type A package outline

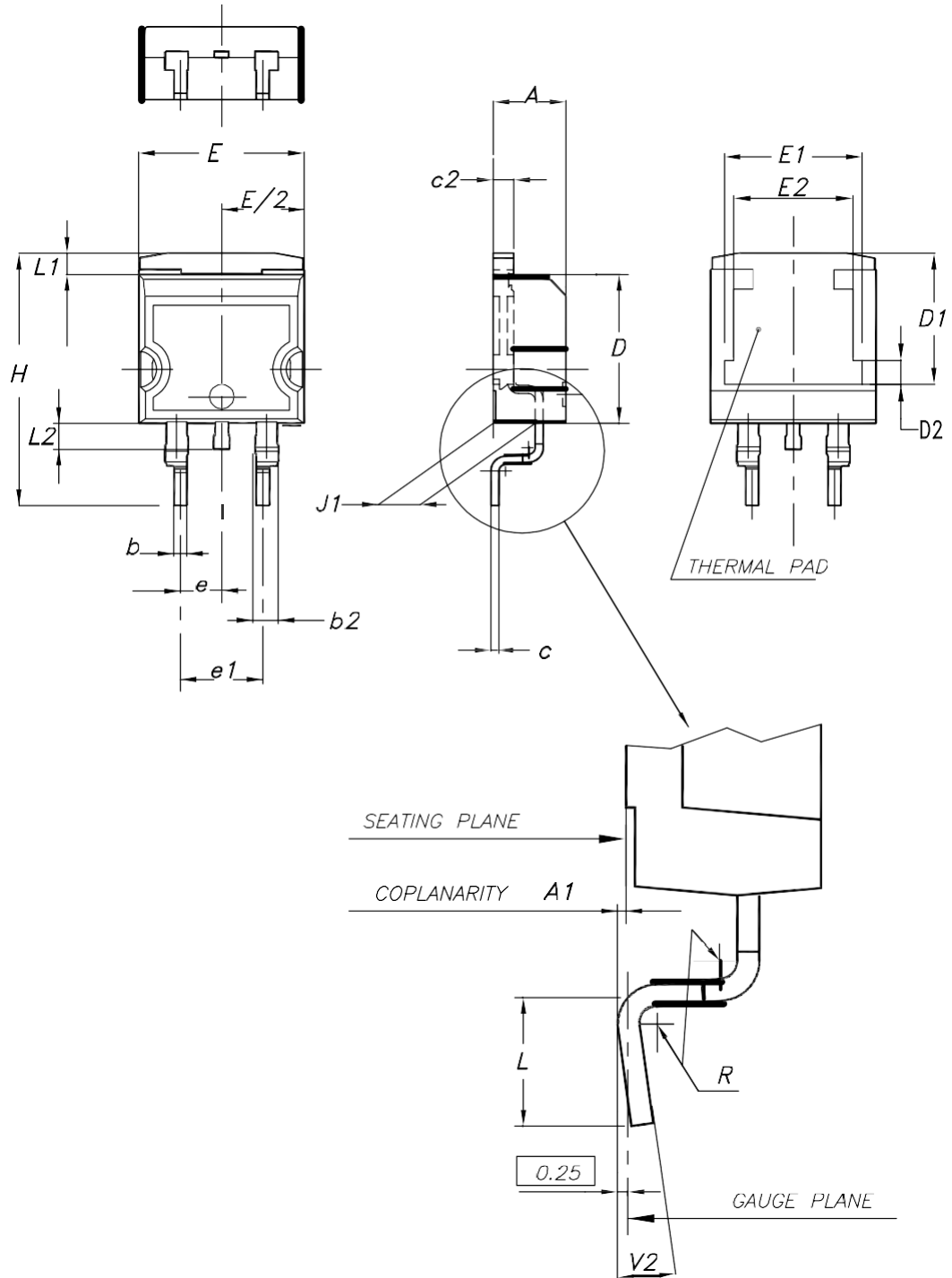

0079457_22_type A

Table 23. D²PAK (SMD 2L STD-ST) mechanical data

Dim.	mm		
	Min.	Typ.	Max.
A	4.40		4.60
A1	0.03		0.23
b	0.70		0.93
b2	1.14		1.70
c	0.45		0.60
c2	1.23		1.36
D	8.95		9.35
D1	7.50	7.75	8.00
D2	1.10	1.30	1.50
E	10		10.40
E1	8.50	8.70	8.90
E2	6.85	7.05	7.25
e		2.54	
e1	4.88		5.28
H	15		15.85
J1	2.49		2.69
L	2.29		2.79
L1	1.27		1.40
L2	1.30		1.75
R		0.4	
V2	0°		8°

8.7 D²PAK (ASE) type B package information

Figure 46. D²PAK (ASE subcon) type B package outline

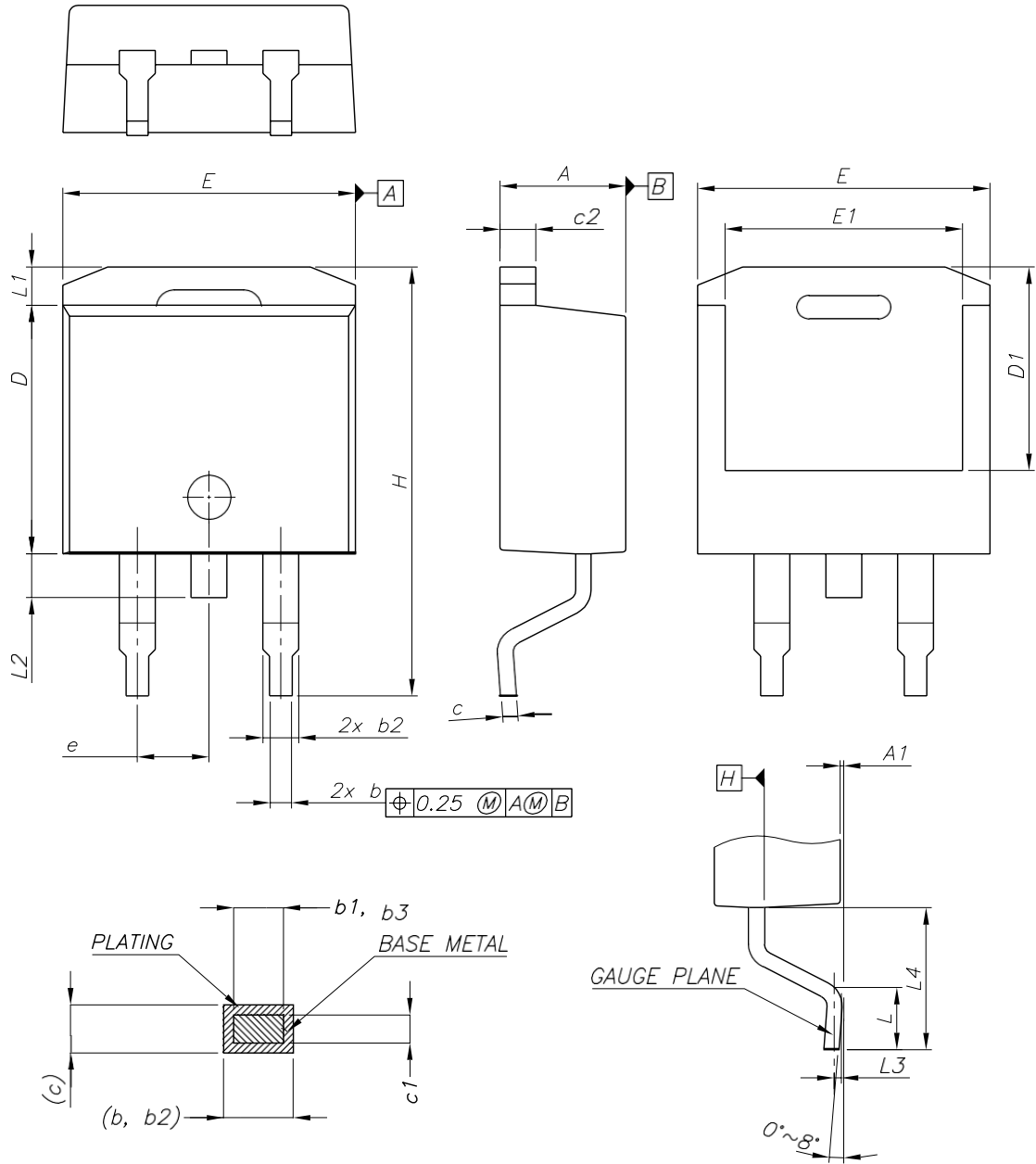

0079457_23_type B

Table 24. D²PAK (ASE) type B mechanical data

Dim.	mm		
	Min.	Typ.	Max.
A	4.36		4.56
A1	0		0.25
b	0.70		0.90
b1	0.51		0.89
b2	1.17		1.37
b3	1.36		1.46
c	0.38		0.694
c1	0.38		0.534
c2	1.19		1.34
D	8.60		9.00
D1	6.90		7.50
E	10.15		10.55
E1	8.10		8.70
e		2.54	
H	15.00		15.60
L	1.90		2.50
L1			1.65
L2			1.78
L3		0.25	
L4	4.78		5.28

Figure 47. D²PAK recommended footprint (dimensions are in mm)

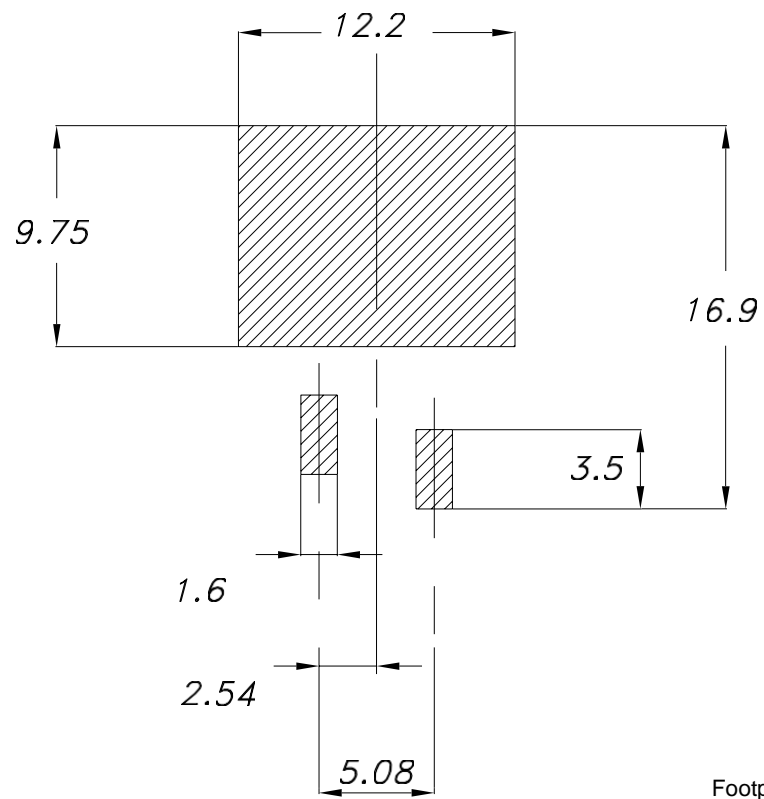

Footprint_0079457

8.8 D²PAK and DPAK packing information

Figure 48. Tape outline

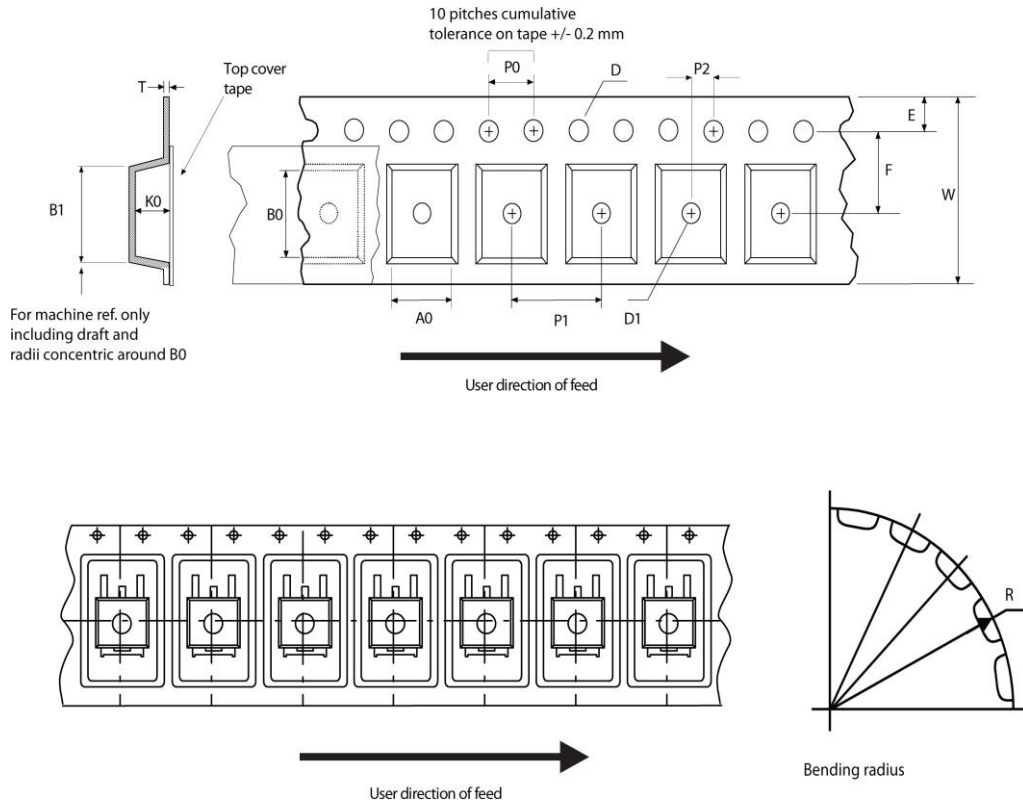

AM08852v1

Figure 49. Reel outline

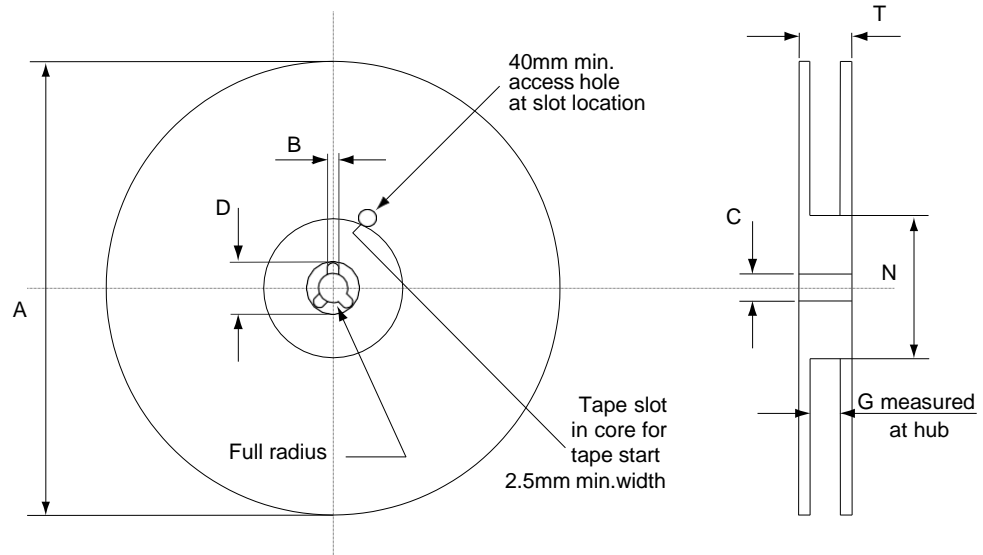

AM06038v1

Table 25. D²PAK tape and reel mechanical data

Tape			Reel		
Dim.	mm		Dim.	mm	
	Min.	Max.		Min.	Max.
A0	10.5	10.7	A		330
B0	15.7	15.9	B	1.5	
D	1.5	1.6	C	12.8	13.2
D1	1.59	1.61	D	20.2	
E	1.65	1.85	G	24.4	26.4
F	11.4	11.6	N	100	
K0	4.8	5.0	T		30.4
P0	3.9	4.1			
P1	11.9	12.1	Base quantity		1000
P2	1.9	2.1	Bulk quantity		1000
R	50				
T	0.25	0.35			
W	23.7	24.3			

Table 26. DPAK tape and reel mechanical data

Tape			Reel		
Dim.	mm		Dim.	mm	
	Min.	Max.		Min.	Max.
A0	6.8	7	A		330
B0	10.4	10.6	B	1.5	
B1		12.1	C	12.8	13.2
D	1.5	1.6	D	20.2	
D1	1.5		G	16.4	18.4
E	1.65	1.85	N	50	
F	7.4	7.6	T		22.4
K0	2.55	2.75			
P0	3.9	4.1	Base qty.		2500
P1	7.9	8.1	Bulk qty.		2500
P2	1.9	2.1			
R	40				
T	0.25	0.35			
W	15.7	16.3			

9 Ordering information

Table 27. Order codes

Part number	Order codes					Output voltages
	TO-220 (single gauge)	TO-220 (dual gauge)	DPAK	D ² PAK	TO-220FP	
L7805C	L7805CV	L7805CV-DG	L7805CDT-TR	L7805CD2T-TR	L7805CP	5 V
L7805AB	L7805ABV	L7805ABV-DG		L7805ABD2T-TR	L7805ABP	5 V
L7805AC	L7805ACV	L7805ACV-DG		L7805ACD2T-TR	L7805ACP	5 V
L7806C	L7806CV	L7806CV-DG		L7806CD2T-TR		6 V
L7806AB	L7806ABV	L7806ABV-DG		L7806ABD2T-TR		6 V
L7806AC	L7806ACV	L7806ACV-DG				6 V
L7808C	L7808CV	L7808CV-DG		L7808CD2T-TR		8 V
L7808AB	L7808ABV	L7808ABV-DG		L7808ABD2T-TR		8 V
L7808AC	L7808ACV	L7808ACV-DG				8 V
L7885C	L7885CV					8.5 V
L7809C	L7809CV	L7809CV-DG		L7809CD2T-TR	L7809CP	9 V
L7809AB	L7809ABV	L7809ABV-DG		L7809ABD2T-TR		9 V
L7809AC	L7809ACV					9 V
L7812C	L7812CV	L7812CV-DG		L7812CD2T-TR	L7812CP	12 V
L7812AB	L7812ABV	L7812ABV-DG		L7812ABD2T-TR		12 V
L7812AC	L7812ACV	L7812ACV-DG		L7812ACD2T-TR		12 V
L7815C	L7815CV	L7815CV-DG		L7815CD2T-TR	L7815CP	15 V
L7815AB	L7815ABV	L7815ABV-DG		L7815ABD2T-TR		15 V
L7815AC	L7815ACV	L7815ACV-DG		L7815ACD2T-TR		15 V
L7818C	L7818CV	L7818CV-DG				18 V
L7824C	L7824CV	L7824CV-DG		L7824CD2T-TR	L7824CP	24 V
L7824AB	L7824ABV	L7824ABV-DG				24 V
L7824AC	L7824ACV	L7824ACV-DG				24 V

Revision history

Table 28. Document revision history

Date	Revision	Changes
21-Jun-2004	12	Document updating.
03-Aug-2006	13	Order codes has been updated and new template.
19-Jan-2007	14	D ² PAK mechanical data has been updated and add footprint data.
31-May-2007	15	Order codes has been updated.
29-Aug-2007	16	Added Table 1 in cover page.
11-Dec-2007	17	Modified: Table 27.
06-Feb-2008	18	Added: TO-220 mechanical data Figure 38 on page 38 , Figure 39 on page 39, and Table 23 on page 37. Modified: Table 27 on page 58.
18-Mar-2008	19	Added: Table 29: DPAK mechanical data on page 50, Table 30: Tape and reel DPAK mechanical data on page 52. Modified: Table 27 on page 58.
26-Jan-2010	20	Modified Table 1 on page 1 and Table 23 on page 37, added: Figure 38 on page 38 and Figure 39 on page 39, Figure 40 on page 45 and Figure 41 on page 45.
04-Mar-2010	21	Added notes Figure 38 on page 38.
08-Sep-2010	22	Modified Table 27 on page 58.
23-Nov-2010	23	Added: TJ = 25 °C test condition in DVO on Table 3, 4, 5, 6, 7, 8 and Table 9.
16-Sep-2011	24	Modified title on page 1.
30-Nov-2011	25	Added: order codes L7805CV-DG, L7806CV-DG, L7808ABV-DG, L7812CV-DG and L7815CV-DG Table 27 on page 58.
08-Feb-2012	26	Added: order codes L7805ACV-DG, L7805ABV-DG, L7806ABV-DG, L7808CV-DG, L7809CV-DG, L7812ACV-DG, L7818CV-DG, L7824CV-DG Table 27 on page 58.
27-Mar-2012	27	Added: order codes L7812ABV-DG, L7815ABV-DG Table 27 on page 58.
27-Apr-2012	28	Modified: VI = 10.4 to 23 V ==> VI = 11.4 to 23 V test conditon value Line regulation Table 6 on page 13.
10-May-2012	29	Added: order codes L7806ACV-DG, L7808ACV-DG, L7815ACV-DG, L7824ABV-DG and L7824ACV-DG Table 27 on page 58.
19-Sep-2012	30	Modified load regulation units from V to mV in Table 3 to Table 9.
12-Mar-2013	31	Modified: VO output voltage at 25 °C min. value 14.4 V Table 16 on page 23.
04-Mar-2014	32	Part numbers L78xx, L78xxC, L78xxAB, L78xxAC changed to L78. Removed TO-3 package. Updated the description in cover page, Section 2: Pin configuration, Section 3: Maximum ratings, Section 4: Test circuits, Section 5: Electrical characteristics, Section 6: Application information, Section 8: Package information and Table 27: Order codes. Added Section 9: Packaging mechanical data. Minor text changes.
26-Feb-2016	33	Updated Section 8: Package information. Minor text changes.
28-Nov-2016	34	Updated Section 9: "Ordering information". Minor text changes.
25-May-2018	35	Updated D ² PAK package Section 8.7 D ² PAK (ASE) type B package information.
17-Sep-2018	36	Updated Figure 29. Dropout voltage vs junction temperature .

Contents

1	Diagram	2
2	Pin configuration	3
3	Maximum ratings	4
4	Test circuits	5
5	Electrical characteristics	6
6	Application information	22
	6.1 Design consideration	22
7	Typical performance	30
8	Package information	32
	8.1 TO-220 (dual gauge) package information.....	32
	8.2 TO-220 (single gauge) package information.....	34
	8.3 TO-220FP package information	36
	8.4 TO-220 packing information	38
	8.5 DPAK package information.....	39
	8.6 D ² PAK (SMD 2L STD-ST) type A package information	41
	8.7 D ² PAK (ASE subcon) type B package information	43
	8.8 D ² PAK and DPAK packing information	46
9	Ordering information	50
	Revision history	51
	Contents	52
	List of tables	53
	List of figures	54

List of tables

Table 1.	Absolute maximum ratings	4
Table 2.	Thermal data.....	4
Table 3.	Electrical characteristics of L7805A	6
Table 4.	Electrical characteristics of L7806A	7
Table 5.	Electrical characteristics of L7808A	8
Table 6.	Electrical characteristics of L7809A	9
Table 7.	Electrical characteristics of L7812A	10
Table 8.	Electrical characteristics of L7815A	11
Table 9.	Electrical characteristics of L7824A	12
Table 10.	Electrical characteristics of L7805C	13
Table 11.	Electrical characteristics of L7806C	14
Table 12.	Electrical characteristics of L7808C	15
Table 13.	Electrical characteristics of L7885C	16
Table 14.	Electrical characteristics of L7809C	17
Table 15.	Electrical characteristics of L7812C	18
Table 16.	Electrical characteristics of L7815C	19
Table 17.	Electrical characteristics of L7818C	20
Table 18.	Electrical characteristics of L7824C	21
Table 19.	TO-220 (dual gauge) mechanical data.....	34
Table 20.	TO-220 (single gauge) mechanical data.....	36
Table 21.	TO-220FP package mechanical data.....	38
Table 22.	DPAK mechanical data	40
Table 23.	D ² PAK (SMD 2L STD-ST) mechanical data.....	43
Table 24.	D ² PAK (ASE) type B mechanical data	45
Table 25.	D ² PAK tape and reel mechanical data	48
Table 26.	DPAK tape and reel mechanical data	49
Table 27.	Order codes.....	50
Table 28.	Document revision history.....	51

List of figures

Figure 2.	Block diagram	2
Figure 3.	Pin connections (top view)	3
Figure 4.	Schematic diagram	3
Figure 5.	Application circuits	4
Figure 6.	DC parameter	5
Figure 7.	Load regulation	5
Figure 8.	Ripple rejection	5
Figure 9.	Fixed output regulator	22
Figure 10.	Current regulator	23
Figure 11.	Circuit for increasing output voltage	23
Figure 12.	Adjustable output regulator (7 to 30 V)	23
Figure 13.	0.5 to 10 V regulator	24
Figure 14.	High current voltage regulator	24
Figure 15.	High output current with short circuit protection	24
Figure 16.	Tracking voltage regulator	25
Figure 17.	Split power supply ($\pm 15\text{ V} - 1\text{ A}$)	25
Figure 18.	Negative output voltage circuit	26
Figure 19.	Switching regulator	26
Figure 20.	High input voltage circuit (configuration 1)	26
Figure 21.	High input voltage circuit (configuration 2)	27
Figure 22.	High input and output voltage	27
Figure 23.	Reducing power dissipation with dropping resistor	27
Figure 24.	Remote shutdown	28
Figure 25.	Power AM modulator (unity voltage gain, $I_O \leq 0.5$)	28
Figure 26.	Adjustable output voltage with temperature compensation	28
Figure 27.	Light controllers ($V_{O(\min)} = V_{XX} + V_{BE}$)	29
Figure 28.	Protection against input short-circuit with high capacitance loads	29
Figure 29.	Dropout voltage vs junction temperature	30
Figure 30.	Peak output current vs input/output differential voltage	30
Figure 31.	Supply voltage rejection vs frequency	30
Figure 32.	Output voltage vs junction temperature	30
Figure 33.	Output impedance vs frequency	31
Figure 34.	Quiescent current vs junction temp.	31
Figure 35.	Load transient response	31
Figure 36.	Line transient response	31
Figure 37.	Quiescent current vs. input voltage	31
Figure 38.	TO-220 (dual gauge) package outline	33
Figure 39.	TO-220 (single gauge) package outline	35
Figure 40.	TO-220FP package outline	37
Figure 41.	Tube for TO-220 (dual gauge) (mm.)	38
Figure 42.	Tube for TO-220 (single gauge) (mm.)	39
Figure 43.	DPAK package outline	39
Figure 44.	DPAK recommended footprint (dimensions are in mm)	41
Figure 45.	D ² PAK (SMD 2L STD-ST) type A package outline	42
Figure 46.	D ² PAK (ASE subcon) type B package outline	44
Figure 47.	D ² PAK recommended footprint (dimensions are in mm)	46
Figure 48.	Tape outline	47
Figure 49.	Reel outline	48

IMPORTANT NOTICE – PLEASE READ CAREFULLY

STMicroelectronics NV and its subsidiaries (“ST”) reserve the right to make changes, corrections, enhancements, modifications, and improvements to ST products and/or to this document at any time without notice. Purchasers should obtain the latest relevant information on ST products before placing orders. ST products are sold pursuant to ST’s terms and conditions of sale in place at the time of order acknowledgement.

Purchasers are solely responsible for the choice, selection, and use of ST products and ST assumes no liability for application assistance or the design of Purchasers’ products.

No license, express or implied, to any intellectual property right is granted by ST herein.

Resale of ST products with provisions different from the information set forth herein shall void any warranty granted by ST for such product.

ST and the ST logo are trademarks of ST. All other product or service names are the property of their respective owners.

Information in this document supersedes and replaces information previously supplied in any prior versions of this document.

© 2018 STMicroelectronics – All rights reserved