



گروه فنی مهندسی جوش و برش مقدم

اعتماد از شما کیفیت و تخصص از ما



09153223758



051-37581400



<https://www.moghadamwelding>



<http://instagram.com/moghadam>



<https://t.me/moghadamwelding>



<https://whatsapp.com/channel>



<https://rubika.ir/moghadamwelding>



مشهد خیام شمالی 63 خیابان پردیس 3

برای کسب اطلاعات بیشتر بر روی لینک ها کلیک کنید

- 7 سال سابقه آموزش تعمیرات تخصصی دستگاه های جوش اینورتری تک فاز و 3 فاز
- 7 سال سابقه فروش قطعات الکترونیکی دستگاه جوش تک فاز و 3 فاز
- آموزش تخصصی تحلیل دستگاه های جوش اینورتری مختص ابراز فروشان
- آموزش تخصصی ابراز آلات شارژی

KA3525A

SMPS Controller

Features

- 5V ±1% Reference
- Oscillator Sync Terminal
- Internal Soft Start
- Deadtime Control
- Under Voltage Lockout

Description

The KA3525A is a monolithic integrated circuit that includes all of the control circuits necessary for a pulse width modulating regulator. There are a voltage reference, an error amplifier, a pulse width modulator, an oscillator, an under voltage lockout, a soft start circuit, and the output driver in the chip.

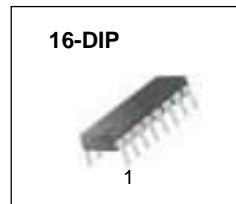

Internal Block Diagram

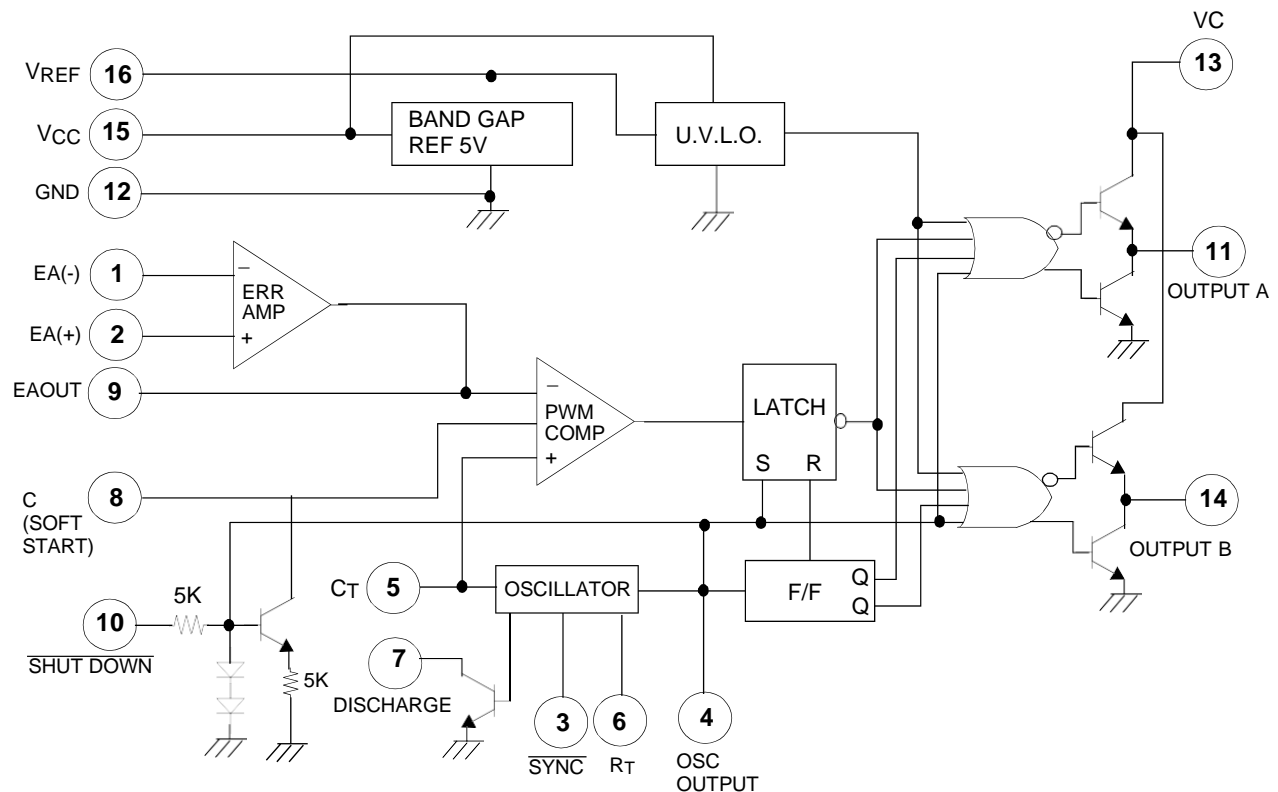

Absolute Maximum Ratings

Parameter	Symbol	Value	Unit
Supply Voltage	V _{CC}	40	V
Collector Supply Voltage	V _C	40	V
Output Current, Sink or Source	I _O	500	mA
Reference Output Current	I _{REF}	50	mA
Oscillator Charging Current	I _{CHG(OSC)}	5	mA
Power Dissipation (T _A = 25°C)	P _D	1000	m/W
Operating Temperature	T _{OPR}	0 ~ +70	°C
Storage Temperature	T _{STG}	-65 ~ +150	°C
Lead Temperature (Soldering, 10sec)	T _{LEAD}	+300	°C

Electrical Characteristics

(V_{CC} = 20V, T_A = 0 to +70°C, unless otherwise specified)

Parameter	Symbol	Conditions	Min.	Typ.	Max.	Unit
REFERENCE SECTION						
Reference Output Voltage	V _{REF}	T _J = 25°C	5.0	5.1	5.2	V
Line Regulation	ΔV _{REF}	V _{CC} = 8 to 35V	-	9	20	mV
Load Regulation	ΔV _{REF}	I _{REF} = 0 to 20mA	-	20	50	mV
Short Circuit Output Current	I _{SC}	V _{REF} = 0, T _J = 25°C	-	80	100	mA
Total Output Variation (Note1)	ΔV _{REF}	Line, Load and Temperature	4.95	-	5.25	V
Temperature Stability (Note1)	ST _T	-	-	20	50	mV
Long Term Stability (Note1)	ST	T _J = 125°C, 1KHRS	-	20	50	mV
OSCILLATOR SECTION						
Initial Accuracy (Note1, 2)	ACCUR	T _J = 25°C	-	±3	±6	%
Frequency Change With Voltage	Δf/ΔV _{CC}	V _{CC} = 8 to 35V (Note1, 2)	-	±0.8	±2	%
Maximum Frequency	f(MAX)	R _T = 2kΩ, C _T = 470pF	400	430	-	kHz
Minimum Frequency	f(MIN)	R _T = 200kΩ, C _T = 0.1μF	-	60	120	Hz
Clock Amplitude (Note1, 2)	V(CLK)	-	3	4	-	V
Clock Width (Note1, 2)	t _{W(CLK)}	T _J = 25°C	0.3	0.6	1	μs
Sync Threshold	V _{TH(SYNC)}	-	1.2	2	2.8	V
Sync Input Current	I _{I(SYNC)}	Sync = 3.5V	-	1.3	2.5	mA

Electrical Characteristics (Continued)

(VCC = 20V, TA = 0 to +70°C, unless otherwise specified)

Parameter	Symbol	Conditions	Min.	Typ.	Max.	Unit
ERROR AMPLIFIER SECTION (VCM = 5.1V)						
Input Offset Voltage	VIO	-	-	1.5	10	mV
Input Bias Current	IBIAS	-	-	1	10	μA
Input Offset Current	IIO	-	-	0.1	1	μA
Open Loop Voltage Gain	GVO	RL ≥ 10MΩ	60	80	-	dB
Common Mode Rejection Ratio	CMRR	VCM = 1.5 to 5.2V	60	90	-	dB
Power Supply Rejection Ratio	PSRR	VCC = 8 to 3.5V	50	60	-	dB
PWM COMPARATOR SECTION						
Minimum Duty Cycle	D(MIN)	-	-	-	0	%
Maximum Duty Cycle	D(MAX)	-	45	49	-	%
Input Threshold Voltage (Note2)	VTH1	Zero Duty Cycle	0.7	0.9	-	V
Input Threshold Voltage (Note2)	VTH2	Max Duty Cycle	-	3.2	3.6	V
SOFT-START SECTION						
Soft Start Current	ISOFT	VSD = 0V, VSS = 0V	25	51	80	μA
Soft Start Low Level Voltage	VSL	VSD = 25V	-	0.3	0.7	V
Shutdown Threshold Voltage	VTH(SD)	-	0.9	1.3	1.7	V
Shutdown Input Current	IN(SD)	VSD = 2.5V	-	0.3	1	mA
OUTPUT SECTION						
Low Output Voltage I	VOL I	ISINK = 20mA	-	0.1	0.4	V
Low Output Voltage II	VOL II	ISINK = 100mA	-	0.05	2	V
High Output Voltage I	VCH I	ISOURCE = 20mA	18	19	-	V
High Output Voltage II	VCH II	ISOURCE = 100mA	17	18	-	V
Under Voltage Lockout	VUV	V8 and V9 = High	6	7	8	V
Collector Leakage Current	ILKG	VCC = 35V	-	80	200	μA
Rise Time (Note1)	tR	CL = 1uF, TJ = 25°C	-	80	600	ns
Fall Time (Note1)	tF	CL = 1uF, TJ = 25°C	-	70	300	ns
STANDBY CURRENT						
Supply Current	ICC	VCC = 35V	-	12	20	mA

Note :

1. These parameters, although guaranteed over the recommended operating conditions, are not 100% tested in production
2. Tested at fOSC=40kHz (RT =3.6K, CT =0.01uF, RI = 0Ω)

Test Circuit

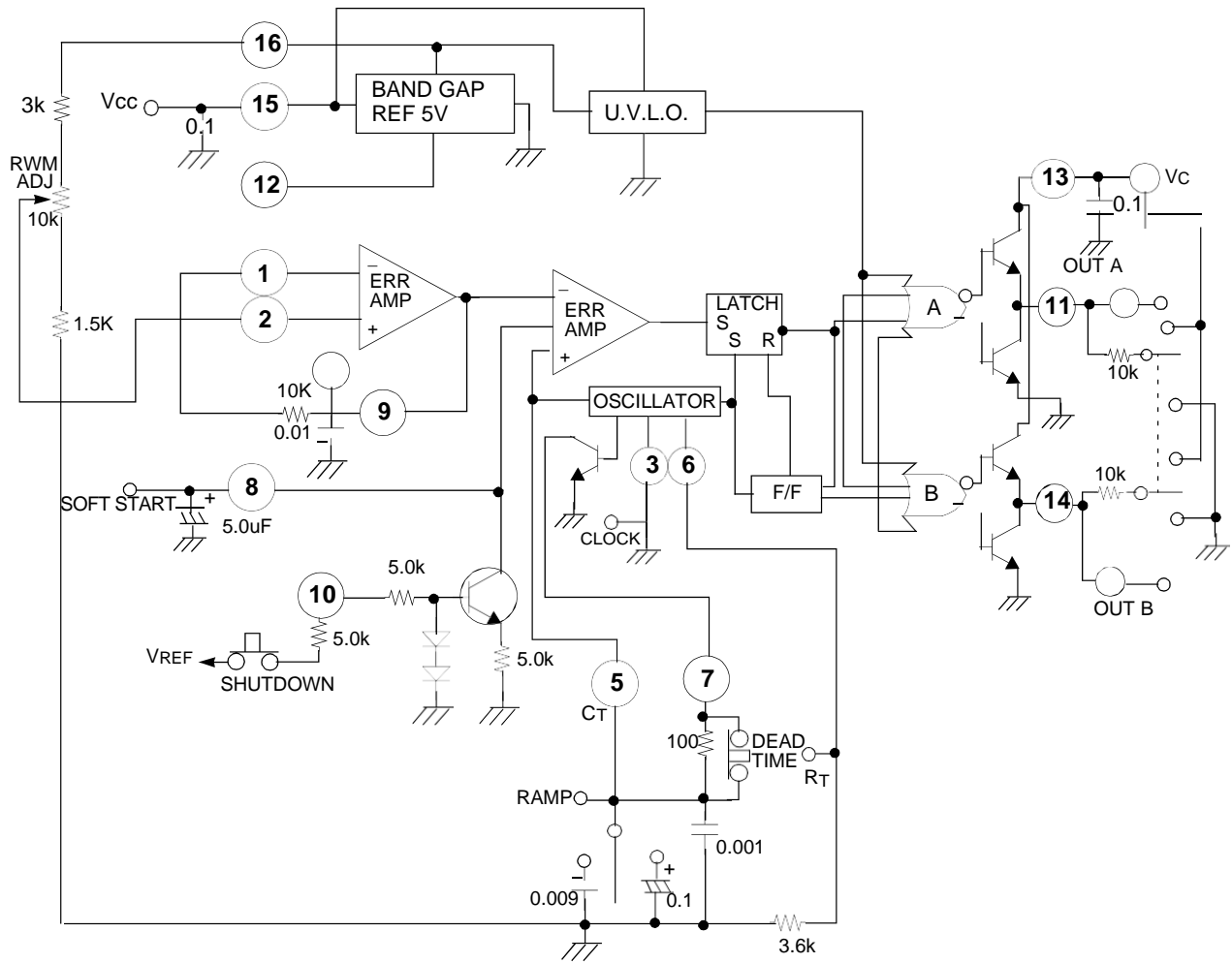

Mechanical Dimensions

Package

16-DIP

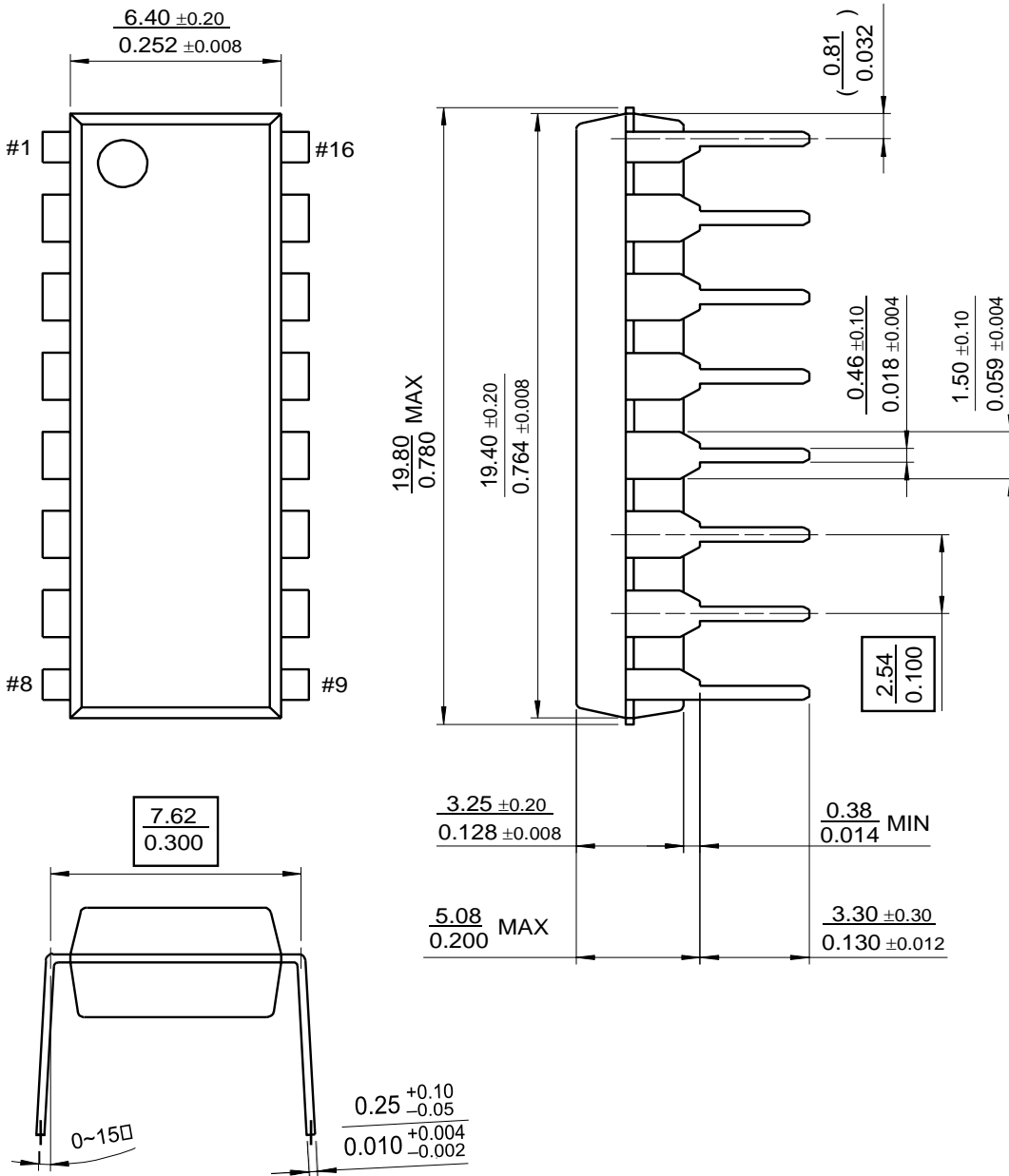

Ordering Information

Product Number	Package	Operating Temperature
KA3525A	16-DIP	0 ~ +70°C

DISCLAIMER

FAIRCHILD SEMICONDUCTOR RESERVES THE RIGHT TO MAKE CHANGES WITHOUT FURTHER NOTICE TO ANY PRODUCTS HEREIN TO IMPROVE RELIABILITY, FUNCTION OR DESIGN. FAIRCHILD DOES NOT ASSUME ANY LIABILITY ARISING OUT OF THE APPLICATION OR USE OF ANY PRODUCT OR CIRCUIT DESCRIBED HEREIN; NEITHER DOES IT CONVEY ANY LICENSE UNDER ITS PATENT RIGHTS, NOR THE RIGHTS OF OTHERS.

LIFE SUPPORT POLICY

FAIRCHILD'S PRODUCTS ARE NOT AUTHORIZED FOR USE AS CRITICAL COMPONENTS IN LIFE SUPPORT DEVICES OR SYSTEMS WITHOUT THE EXPRESS WRITTEN APPROVAL OF THE PRESIDENT OF FAIRCHILD SEMICONDUCTOR CORPORATION. As used herein:

1. Life support devices or systems are devices or systems which, (a) are intended for surgical implant into the body, or (b) support or sustain life, and (c) whose failure to perform when properly used in accordance with instructions for use provided in the labeling, can be reasonably expected to result in a significant injury of the user.
2. A critical component in any component of a life support device or system whose failure to perform can be reasonably expected to cause the failure of the life support device or system, or to affect its safety or effectiveness.