

گروه فنی مهندسی جوش و برش مقدم

اعتماد از شما کیفیت و تخصص از ما



09153223758



051-37581400



<https://www.moghadamwelding>



<http://instagram.com/moghadam>



<https://t.me/moghadamwelding>



<https://whatsapp.com/channel>



<https://rubika.ir/moghadamwelding>



مشهد خیام شمالی 63 خیابان پردیس 3

برای کسب اطلاعات بیشتر بر روی لینک ها کلیک کنید

• 7 سال سابقه آموزش تعمیرات تخصصی دستگاه های

جوش اینورتری تک فاز و 3 فاز

• 7 سال سابقه فروش قطعات الکترونیکی دستگاه جوش

تک فاز و 3 فاز

• آموزش تخصصی تحلیل دستگاه های جوش اینورتری

مختص ابراز فروشان

• آموزش تخصصی ابراز آلات شارژی



This integrated circuit can be damaged by ESD. Texas Instruments recommends that all integrated circuits be handled with appropriate precautions. Failure to observe proper handling and installation procedures can cause damage.

ESD damage can range from subtle performance degradation to complete device failure. Precision integrated circuits may be more susceptible to damage because very small parametric changes could cause the device not to meet its published specifications.

ORDERING INFORMATION

| T _A | PACKAGED DEVICES | | | | | |
|-----------------|-----------------------------|-------------|------------------------------|-----------------------------|--------------|-------------|
| | SOIC-20 (DW) ⁽¹⁾ | PDIP-20 (N) | TSSOP-20 (PW) ⁽¹⁾ | PLCC-20 (FN) ⁽¹⁾ | LCCC-20 (FK) | CDIP-20 (J) |
| -55°C to +125°C | | | | | UCC1895L | UCC1895J |
| -40°C to +85°C | UCC2895DW | UCC2895N | UCC2895PW | UCC2895Q | | |
| 0°C to 70°C | UCC3895DW | UCC3895N | UCC3895PW | UCC3895Q | | |

(1) The DW, PW and Q packages are available taped and reeled. Add TR suffix to device type (for example: UCC2895DWTR) to order quantities of 2000 devices per reel for DW.

ABSOLUTE MAXIMUM RATINGS

All voltage values are with respect to the network ground terminal unless otherwise noted.⁽¹⁾

| | | VALUE | | UNIT |
|--|---|-------|-----------|------|
| | | MIN | MAX | |
| Supply voltage | | | 17 | V |
| Output current | | | 100 | mA |
| Reference current | | | 15 | |
| Supply current | | | 30 | |
| Analog inputs | EAP, EAN, EAOUT, RAMP, SYNC, ADS, CS, SS/DISB | -0.3 | REF + 0.3 | |
| Drive outputs | OUTA, OUTB, OUTC, OUTD | -0.3 | VCC + 0.3 | |
| Power dissipation at T _A = 25°C | DW-20 package | | 650 | mW |
| | N-20 package | | 1 | W |
| T _J Junction temperature range | | -55 | 150 | °C |
| Lead temperature 1.6 mm (1/16 in) from case for 10 seconds | | | 300 | |
| T _{stg} Storage temperature range | | -65 | 150 | |

(1) Stresses beyond those listed under *absolute maximum ratings* may cause permanent damage to the device. These are stress ratings only, and functional operation of the device at these or any other conditions beyond those indicated under *recommended operating conditions* is not implied. Exposure to Absolute Maximum Rated conditions for extended periods may affect device reliability

THERMAL CHARACTERISTICS

| PART | T _{JA} | T _{JC} | UNIT |
|-----------|-----------------|-----------------|------|
| UCC2895DW | 90 | 25 | °C/W |
| UCC2895N | 80 | 35 | |
| UCC2895PW | 125 | 14 | |
| UCC2895Q | 75 | 34 | |
| UCC1895J | 85 | 28 | |
| UCC1895L | 80 | 20 | |

RECOMMENDED OPERATING CONDITIONS⁽¹⁾

| | | MIN | NOM | MAX | UNIT |
|---|--|-----------------------|-----|------|------|
| V _{DD} | Supply voltage | 10 | | 16.5 | V |
| V _{DD} | Supply voltage bypass capacitor ⁽²⁾ | 10 × C _{REF} | | | μF |
| C _{REF} | Reference bypass capacitor (UCC1895) ⁽³⁾ | 0.1 | | 1.0 | |
| C _{REF} | Reference bypass capacitor (UCC2895, UCC3895) ⁽³⁾ | 0.1 | | 4.7 | |
| C _T | Timing capacitor (for 500-kHz switching frequency) | | 220 | | pF |
| R _T | Timing resistor (for 500-kHz switching frequency) | | 82 | | kΩ |
| R _{DEL_AB} , R _{DEL_CD} | Delay resistor | 2.5 | | 40 | |
| T _J | Operating junction temperature ⁽⁴⁾ | –55 | | 125 | °C |

- (1) TI recommends that there be a single point grounded between GND and PGND directly under the device. There must be a separate ground plane associated with the GND pin and all components associated with pins 1 through 12, plus 19 and 20, be located over this ground plane. Any connections associated with these pins to ground must be connected to this ground plane.
- (2) The V_{DD} capacitor must be a low ESR, ESL ceramic capacitor located directly across the V_{DD} and PGND pins. A larger bulk capacitor must be located as physically close as possible to the V_{DD} pins.
- (3) The V_{REF} capacitor must be a low ESR, ESL ceramic capacitor located directly across the REF and GND pins. If a larger capacitor is desired for the V_{REF} then it must be located near the V_{REF} cap and connected to the V_{REF} pin with a resistor of 51 Ω or greater. The bulk capacitor on V_{DD} must be a factor of 10 greater than the total V_{REF} capacitance.
- (4) TI does not recommend that the device operate under conditions beyond those specified in this table for extended periods of time.

ELECTRICAL CHARACTERISTICS

V_{DD} = 12 V, R_T = 82 kΩ, C_T = 220 pF, R_{DELAB} = 10 kΩ, R_{DELCD} = 10 kΩ, C_{REF} = 0.1 μF, C_{VDD} = 0.1 μF and no load on the outputs, T_A = T_J. T_A = 0°C to 70°C for UCC3895x, T_A = –40°C to +85°C for UCC2895x and T_A = –55°C to +125°C for the UCC1895x. (unless otherwise noted)

| PARAMETER | TEST CONDITIONS | MIN | TYP | MAX | UNIT | | |
|------------------------------------|--|---|-----|------|------|------|------|
| UVLO (UNDERVOLTAGE LOCKOUT) | | | | | | | |
| UVLO _(on) | Start-up voltage threshold | 10.2 | 11 | 11.8 | V | | |
| UVLO _(off) | Minimum operating voltage after start-up | 8.2 | 9 | 9.8 | | | |
| UVLO _(hys) | Hysteresis | 1 | 2 | 3 | | | |
| SUPPLY | | | | | | | |
| I _{START} | Start-up current | V _{DD} = 8 V | | 150 | 250 | μA | |
| I _{DD} | Operating current | | 5 | 6 | | mA | |
| V _{DD_CLAMP} | V _{DD} clamp voltage | I _{DD} = 10 mA | | 16.5 | 17.5 | 18.5 | V |
| VOLTAGE REFERENCE | | | | | | | |
| V _{REF} | Output voltage | T _J = 25°C | | 4.94 | 5 | 5.06 | V |
| | | 10 V < V _{DD} < V _{DD_CLAMP} 0 mA < I _{REF} < 5 mA temperature | | 4.85 | 5 | 5.15 | |
| I _{SC} | Short circuit current | REF = 0 V, T _J = 25°C | | 10 | 20 | | mA |
| ERROR AMPLIFIER | | | | | | | |
| | Common-mode input voltage range | | | –0.1 | 3.6 | | V |
| V _{IO} | Offset voltage | | | –7 | 7 | | mV |
| I _{BIAS} | Input bias current (EAP, EAN) | | | –1 | 1 | | μA |
| EAOUT _{_VOH} | High-level output voltage | EAP-EAN = 500 mV, I _{EAOUT} = –0.5 mA | | 4 | 4.5 | 5 | V |
| EAOUT _{_VOL} | Low-level output voltage | EAP-EAN = –500 mV, I _{EAOUT} = 0.5 mA | | 0 | 0.2 | 0.4 | |
| I _{SOURCE} | Error amplifier output source current | EAP-EAN = 500 mV, EAOUT = 2.5 V | | 1 | 1.5 | | mA |
| I _{SINK} | Error amplifier output sink current | EAP-EAN = –500 mV, EAOUT = 2.5 V | | 2.5 | 4.5 | | |
| A _{VOL} | Open-loop dc gain | | | 75 | 85 | | dB |
| GBW | Unity gain bandwidth ⁽¹⁾ | | | 5 | 7 | | mHz |
| | Slew rate ⁽¹⁾ | 1 V < EAN < 0 V, EAP = 500 mV 0.5 V < EAOUT < 3 V | | 1.5 | 2.2 | | V/μs |

(1) Ensured by design. Not production tested.

ELECTRICAL CHARACTERISTICS (continued)

V_{DD} = 12 V, R_T = 82 kΩ, C_T = 220 pF, R_{DELAB} = 10 kΩ, R_{DELCD} = 10 kΩ, C_{REF} = 0.1 μF, C_{VDD} = 0.1 μF and no load on the outputs, T_A = T_J. T_A = 0°C to 70°C for UCC3895x, T_A = -40°C to +85°C for UCC2895x and T_A = -55°C to +125°C for the UCC1895x. (unless otherwise noted)

| PARAMETER | | TEST CONDITIONS | MIN | TYP | MAX | UNIT |
|---------------------------------|--|--|-------|------|-------|------|
| | No-load comparator turn-off threshold | | 0.45 | 0.5 | 0.55 | V |
| | No-load comparator turn-on threshold | | 0.55 | 0.6 | 0.69 | |
| | No-load comparator hysteresis | | 0.035 | 0.1 | 0.165 | |
| OSCILLATOR | | | | | | |
| f _{OSC} | Frequency | T _J = 25°C | 473 | 500 | 527 | kHZ |
| | Frequency total variation(| Over line, temperature | | 2.5% | 5% | |
| V _{IH_SYNC} | SYNC input threshold, SYNC | | 2.05 | 2.1 | 2.4 | V |
| V _{OH_SYNC} | High-level output voltage, SYNC | I _{SYNC} = -400 μA, V _{CT} = 2.6 V | 4.1 | 4.5 | 5 | |
| V _{OL_SYNC} | Low-level output voltage, SYNC | I _{SYNC} = 100 μA, V _{CT} = 0 V | 0 | 0.5 | 1 | |
| | Sync output pulse width | LOAD _{SYNC} = 3.9 kΩ and 30 pF in parallel | | 85 | 135 | ns |
| V _{RT} | Timing resistor voltage | | 2.9 | 3 | 3.1 | v |
| V _{CT(peak)} | Timing capacitor peak voltage | | 2.25 | 2.35 | 2.55 | |
| V _{CT(valley)} | Timing capacitor valley voltage | | 0 | 0.2 | 0.4 | |
| CURRENT SENSE | | | | | | |
| I _{CS(bias)} | Current sense bias current | 0 V < CS < 2.5 V 0 V ADS < 2.5 V | -4.5 | | 20 | μA |
| | Peak current threshold | | 1.9 | 2 | 2.1 | V |
| | Overcurrent threshold | | 2.4 | 2.5 | 2.6 | V |
| | Current sense to output delay | 0 V ≤ CS ≤ 2.3 V DELAB = DELCD = REF | | 75 | 110 | ns |
| SOFT-START/SHUTDOWN | | | | | | |
| I _{SOURCE} | Softstart source current | SS/DISB = 3.0 V CS = 1.9 V | -40 | -35 | -30 | μA |
| I _{SINK} | Softstart sink current | SS/DISB = 3.0 V, CS = 2.6 V | 325 | 350 | 375 | μA |
| | Softstart/disable comparator threshold | | 0.44 | 0.5 | 0.56 | V |
| ADAPTIVE DELAY SET (ADS) | | | | | | |
| | DELAB/DELCD output voltage | ADS = CS = 0 V | 0.45 | 0.5 | 0.55 | V |
| | | ADS = 0 V CS = 2 V | 1.9 | 2 | 2.1 | |
| t _{DELAY} | Output delay ⁽²⁾⁽³⁾ | ADS = CS = 0 V | 450 | 560 | 620 | ns |
| | ADS bias current | 0 V < ADS < 2.5 V 0 V < CS < 2.5 V | -20 | | 20 | μA |

(2) Ensured by design. Not production tested.

(3) Output delay is measured between OUTA and OUTB, or OUTC and OUTD. Output delay is defined as shown below where: t_{r(OUTA)} = falling edge of OUTA signal, t_{r(OUTB)} = rising edge of OUTB signal (see Figure 1 and Figure 2).

ELECTRICAL CHARACTERISTICS (continued)

V_{DD} = 12 V, R_T = 82 kΩ, C_T = 220 pF, R_{DELAB} = 10 kΩ, R_{DELCD} = 10 kΩ, C_{REF} = 0.1 μF, C_{VDD} = 0.1 μF and no load on the outputs, T_A = T_J. T_A = 0°C to 70°C for UCC3895x, T_A = -40°C to +85°C for UCC2895x and T_A = -55°C to +125°C for the UCC1895x. (unless otherwise noted)

| PARAMETER | | TEST CONDITIONS | MIN | TYP | MAX | UNIT |
|-----------------------|--|--|------|-------|------|------|
| OUTPUT | | | | | | |
| V _{OH} | High-level output voltage (all outputs) | I _{OUT} = -10 mA, V _{DD} to output | | 250 | 400 | mV |
| V _{OL} | Low-level output voltage (all outputs) | I _{OUT} = 10 mA | | 150 | 250 | mV |
| t _R | Rise time ⁽⁴⁾ | C _{LOAD} = 100 pF | | 20 | 35 | ns |
| t _F | Fall time ⁽⁴⁾ | C _{LOAD} = 100 pF | | 20 | 35 | ns |
| PWM COMPARATOR | | | | | | |
| | EAOUT to RAMP input offset voltage | RAMP = 0 V DELAB = DELCD = REF | 0.72 | 0.85 | 1.05 | V |
| | Minimum phase shift ⁽⁵⁾ (OUTA to OUTC, OUTB to OUTD) | RAMP = 0 V EAOUT = 650 mV | 0.0% | 0.85% | 1.4% | |
| t _{DELAY} | Delay ⁽⁶⁾ (RAMP to OUTC, RAMP to OUTD) | 0 V < RAMP < 2.5 V, EAOUT = 1.2 V DELAB = DELCD = REF | | 70 | 120 | ns |
| I _{R(bias)} | RAMP bias current | RAMP < 5 V, C _T = 2.2 V | -5 | | 5 | μA |
| I _{R(sink)} | RAMP sink current | RAMP = 5 V, C _T = 2.6 V | 12 | 19 | | mA |

(4) Ensured by design. Not production tested.

(5) Minimum phase shift is defined as:

$$\Phi = 180 \times \frac{t_{f(OUTC)} - t_{f(OUTA)}}{t_{PERIOD}} \quad \text{or} \quad \Phi = 180 \times \frac{t_{f(OUTC)} - t_{f(OUTB)}}{t_{PERIOD}}$$

where

- (a) t_{f(OUTA)} = falling edge of OUTA signal
- (b) t_{f(OUTB)} = falling edge of OUTB signal
- (c) t_{f(OUTC)} = falling edge of OUTC signal,
- (d) t_{f(OUTD)} = falling edge of OUTD signal
- (e) t_{PERIOD} = period of OUTA or OUTB signal

(6) Output delay is measured between OUTA and OUTB, or OUTC and OUTD. Output delay is defined as shown below where: t_{f(OUTA)} = falling edge of OUTA signal, t_{r(OUTB)} = rising edge of OUTB signal (see Figure 1 and Figure 2).

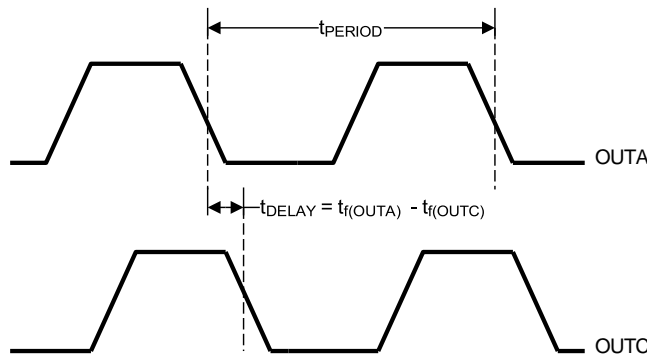

Figure 1. Same Applies to OUTB and OUTD

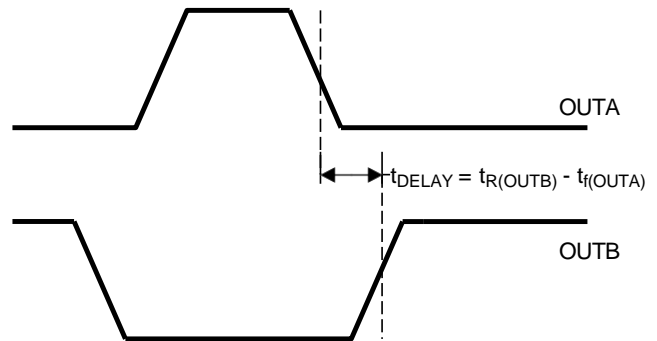
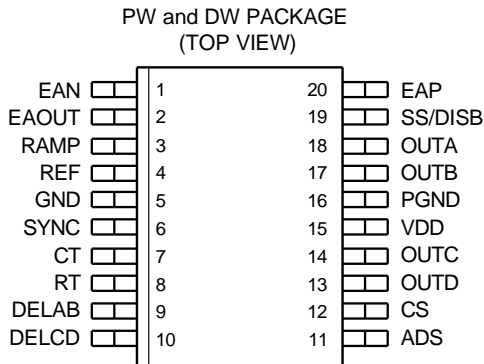

Figure 2. Same Applies to OUTC and OUTD

DEVICE INFORMATION

PW AND DW PACKAGE DRAWINGS (TOP VIEW)



N AND J PACKAGE DRAWINGS (TOP VIEW)

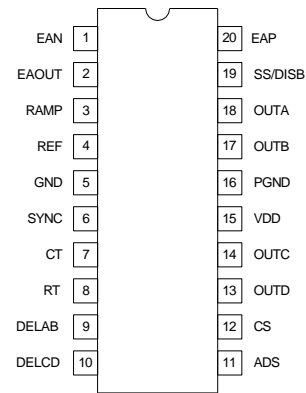

FN AND FK PACKAGE DRAWINGS (TOP VIEW)

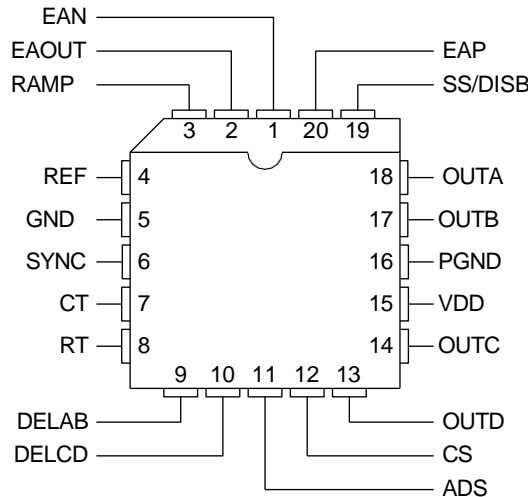

TERMINAL FUNCTIONS

| TERMINAL | | I/O | DESCRIPTION |
|----------|-----|-----|--|
| NAME | NO. | | |
| ADS | 11 | I | The adaptive-delay-set pin sets the ratio between the maximum and minimum programmed output delay dead time. |
| CS | 12 | I | Current sense input for cycle-by-cycle current limiting and for over-current comparator. |
| CT | 7 | I | Oscillator timing capacitor for programming the switching frequency. The UCC3895 oscillator charges CT via a programmed current. |
| DELAB | 9 | I | The delay-programming between complementary-outputs pin, DELAB, programs the dead time between switching of output A and output B. |
| DELCD | 10 | I | The delay-programming between complementary-outputs pin, DELCD, programs the dead time between switching of output C and output D. |
| EAOUT | 2 | I/O | Error amplifier output. |
| EAP | 20 | I | Non-inverting input to the error amplifier. Keep below 3.6 V for proper operation. |
| EAN | 1 | I | Inverting input to the error amplifier. Keep below 3.6 V for proper operation. |
| GND | 5 | - | Chip ground for all circuits except the output stages. |

TERMINAL FUNCTIONS (continued)

| TERMINAL | | I/O | DESCRIPTION |
|----------|-----|-----|--|
| NAME | NO. | | |
| OUTA | 18 | O | The four outputs are 100-mA complementary MOS drivers, and are optimized to drive FET driver circuits such as UCC27424 or gate drive transformers. |
| OUTB | 17 | O | |
| OUTC | 14 | O | |
| OUTD | 13 | O | |
| PGND | 16 | - | Output stage ground. |
| RAMP | 3 | I | Inverting input of the PWM comparator. |
| REF | 4 | O | 5 V, $\pm 1.2\%$, 5 mA voltage reference. For best performance, bypass with a 0.1- μ F low ESR, low ESL capacitor to ground. Do not use more than 4.7 μ F of total capacitance on this pin. |
| RT | 8 | I | Oscillator timing resistor for programming the switching frequency. |
| SS/DISB | 19 | I | Soft-start and disable pin which combines the two independent functions. |
| SYNC | 6 | I/O | The oscillator synchronization pin is bidirectional. |
| VDD | 15 | I | The power supply input pin, VDD, must be bypassed with a minimum of a 1- μ F low ESR, low ESL capacitor to ground. The addition of a 10- μ F low ESR, low ESL between VDD and PGND is recommended. |

BLOCK DIAGRAM

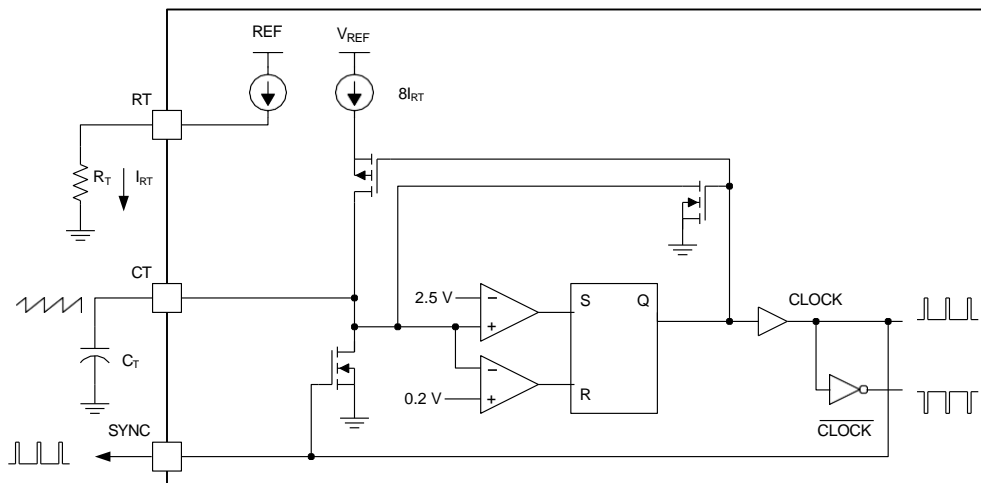
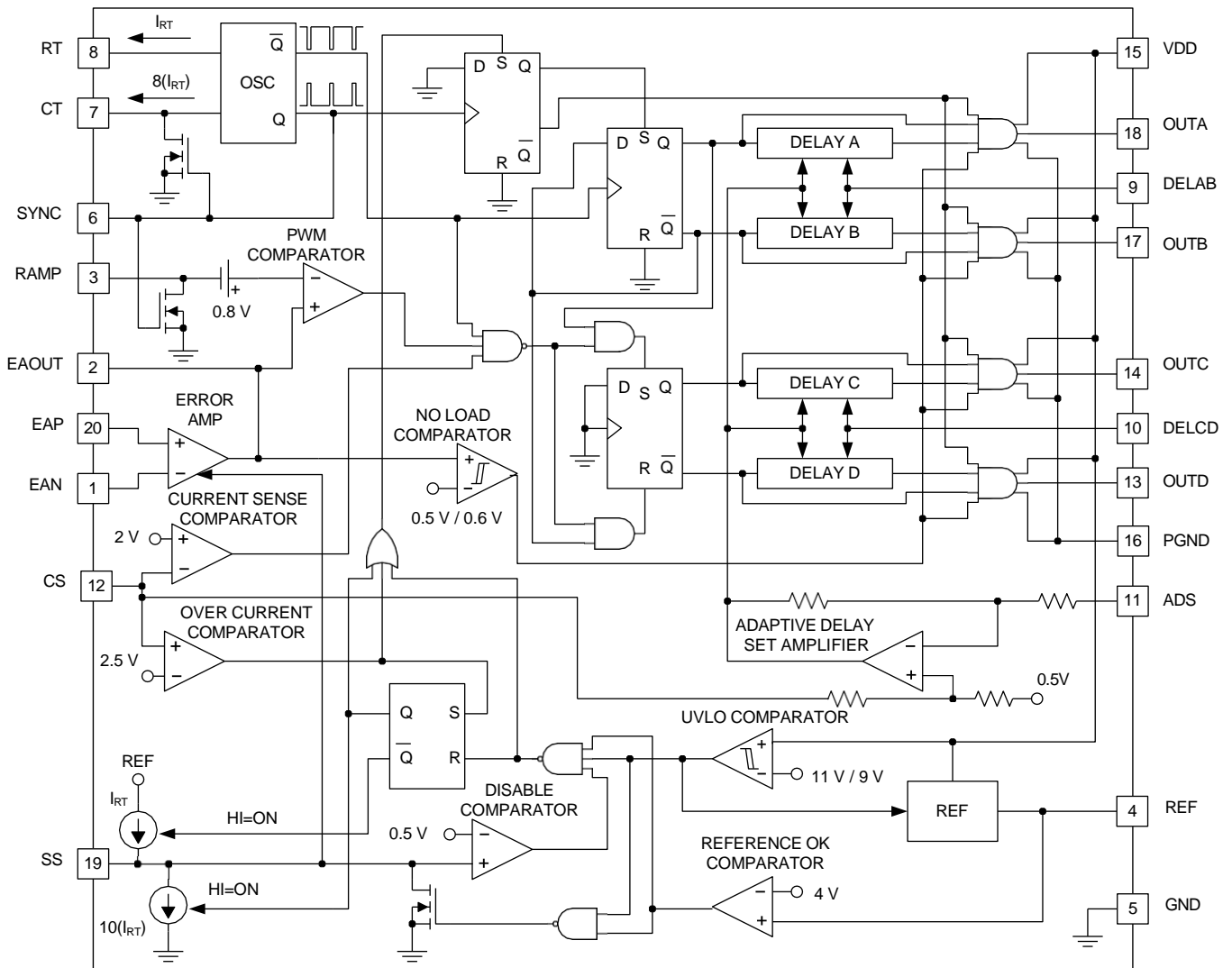

Figure 3. Oscillator Block Diagram

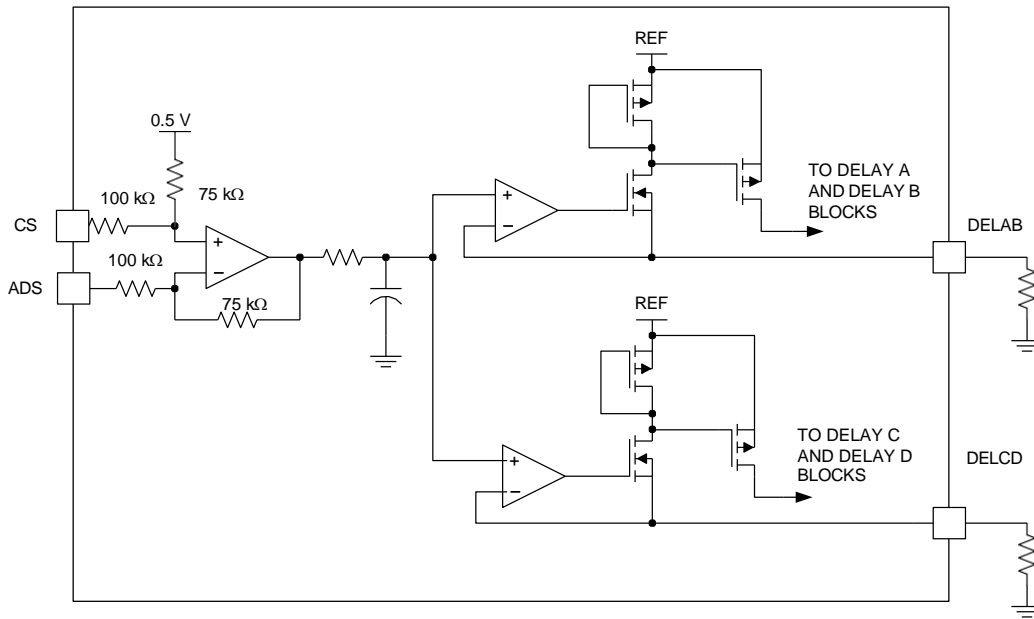

Figure 4. Adaptive Delay Set Block Diagram

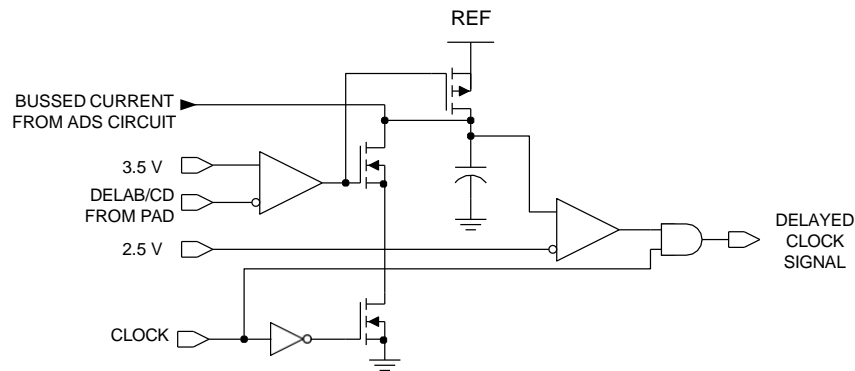

Figure 5. Delay Block Diagram (One Delay Block Per Outlet)

DETAILED PIN DESCRIPTION

ADS (Adaptive Delay Set)

This function sets the ratio between the maximum and minimum programmed output-delay dead time. When the ADS pin is directly connected to the CS pin, no delay modulation occurs. The maximum delay modulation occurs when ADS is grounded. In this case, delay time is four-times longer when CS = 0 than when CS = 2 V (the peak-current threshold), ADS changes the output voltage on the delay pins DELAB and DELCD by [Equation 1](#).

$$V_{\text{DEL}} = \left[0.75 \times (V_{\text{CS}} - V_{\text{ADS}}) \right] + 0.5 \text{ V}$$

where

- V_{CS} and V_{ADS} are in volts (1)

ADS must be limited to between 0 V and 2.5 V and must be less-than or equal-to CS. DELAB and DELCD are clamped to a minimum of 0.5 V.

CS (Current Sense)

The CS input connects to the inverting input of the current-sense comparator and the non-inverting input of the overcurrent comparator and the ADS amplifier. The current sense signal is used for cycle-by-cycle current limiting in peak current-mode control, and for overcurrent protection in all cases with a secondary threshold for output shutdown. An output disable initiated by an overcurrent fault also results in a restart cycle, called soft-stop, with full soft-start.

CT (Oscillator Timing Capacitor)

The UCC3895 oscillator charges CT via a programmed current. The waveform on C_T is a sawtooth, with a peak voltage of 2.35 V. The approximate oscillator period is calculated by [Equation 2](#).

$$t_{\text{OSC}} = \frac{5 \times R_T \times C_T}{48} + 120 \text{ ns}$$

where

- C_T is in Farads
- R_T is in Ohms
- t_{osc} is in seconds
- C_T can range from 100 to 880 pF. (2)

NOTE

A large C_T and a small R_T combination results in extended fall times on the C_T waveform. The increased fall time increases the SYNC pulse width, hence limiting the maximum phase shift between OUTA, OUTB and OUTC, OUTD outputs, which limits the maximum duty cycle of the converter (see to [Figure 3](#)).

DELAB and DELCD (Delay Programming Between Complementary Outputs)

DELAB programs the dead time between switching of OUTA and OUTB. DELCD programs the dead time between OUTC and OUTD. This delay is introduced between complementary outputs in the same leg of the external bridge. The UCC2895N allows the user to select the delay, in which the resonant switching of the external power stages takes place. Separate delays are provided for the two half-bridges to accommodate differences in resonant-capacitor charging currents. The delay in each stage is set according to [Equation 3](#).

$$t_{\text{DELAY}} = \frac{(25 \times 10^{-12}) \times R_{\text{DEL}}}{V_{\text{DEL}}} + 25 \text{ ns}$$

where

- V_{DEL} is in volts
- R_{DEL} is in Ohms
- t_{DELAY} is in seconds (3)

DELAB and DELCD source about 1 mA maximum. Choose the delay resistors so that this maximum is not exceeded. Programmable output delay is defeated by tying DELAB and, or, DELCD to REF. For an optimum performance keep stray capacitance on these pins at less than 10 pF.

EAOUT, EAP, and EAN (Error Amplifier)

EAOUT connects internally to the non-inverting input of the PWM comparator and the no-load comparator. EAOUT is internally clamped to the soft-start voltage. The no-load comparator shuts down the output stages when EAOUT falls below 500 mV, and allows the outputs to turn on again when EAOUT rises above 600 mV.

EAP is the non-inverting and the EAN is the inverting input to the error amplifier.

OUTA, OUTB, OUTC, and OUTD (Output MOSFET Drivers)

The four outputs are 100-mA complementary MOS drivers, and are optimized to drive MOSFET driver circuits. OUTA and OUTB are fully complementary, (assuming no programming delay) and operate near 50% duty cycle and one-half the oscillator frequency. OUTA and OUTB are intended to drive one half-bridge circuit in an external power stage. OUTC and OUTD drive the other half-bridge and have the same characteristics as OUTA and OUTB. OUTC is phase shifted with respect to OUTA, and OUTD is phase shifted with respect to OUTB.

NOTE

Changing the phase relationship of OUTC and OUTD with respect to OUTA and OUTB requires other than the nominal 50% duty ratio on OUTC and OUTD during those transients.

PGND (Power Ground)

To keep output switching noise from critical analog circuits, the UCC3895 has two different ground connections. PGND is the ground connection for the high-current output stages. Both GND and PGND must be electrically tied together. Also, because PGND carries high current, board traces must be low impedance.

RAMP (Inverting Input of the PWM Comparator)

This pin receives either the C_T waveform in voltage and average current-mode controls, or the current signal (plus slope compensation) in peak current-mode control.

REF (Voltage Reference)

The $5\text{-V} \pm 1.2\%$ reference supplies power to internal circuitry, and also supplies up to 5 mA to external loads. The reference is shutdown during undervoltage lockout but is operational during all other disable modes. For best performance, bypass with a $0.1\text{-}\mu\text{F}$ low-ESR low-ESL capacitor to GND. To ensure the stability of the internal reference, do not use more than $1.0\text{ }\mu\text{F}$ of total capacitance on this pin for the UCC1895.

For the UCC2895 and the UCC3895, this capacitance increases as per the limits defined in the [RECOMMENDED OPERATING CONDITIONS](#) table of this specification.

RT (Oscillator Timing Resistor)

The oscillator in the UCC3895 operates by charging an external timing capacitor, C_T , with a fixed current programmed by R_T . R_T current is calculated with [Equation 4](#).

$$I_{RT} \text{ (A)} = \frac{3 \text{ V}}{R_T \text{ (\Omega)}} \quad (4)$$

R_T ranges from 40 to 120 k Ω . Soft-start charging and discharging currents are also programmed by I_{RT} (Refer to [Figure 3](#)).

GND (Analog Ground)

This pin is the chip ground for all internal circuits except the output stages.

SS/DISB (Soft-Start/Disable)

This pin combines two independent functions.

Disable Mode: A rapid shutdown of the chip is accomplished by externally forcing SS/DISB below 0.5 V, externally forcing REF below 4 V, or if VDD drops below the undervoltage lockout threshold. In the case of REF being pulled below 4 V or an undervoltage condition, SS/DISB is actively pulled to ground via an internal MOSFET switch.

If an overcurrent fault is sensed ($CS = 2.5\text{ V}$), a soft-stop is initiated. In this mode, SS/DISB sinks a constant current of $(10 \times I_{RT})$. The soft-stop continues until SS/DISB falls below 0.5 V. When any of these faults are detected, all outputs are forced to ground immediately.

NOTE

If SS/DISB is forced below 0.5 V, the pin starts to source current equal to I_{RT} . The only time the part switches into low I_{DD} current mode, though, is when the part is in undervoltage lockout.

Soft-start Mode: After a fault or disable condition has passed, VDD is above the start threshold, and, or, SS/DISB falls below 0.5 V during a soft-stop, SS/DISB switches to a soft-start mode. The pin then sources current, equal to I_{RT} . A user-selected resistor/capacitor combination on SS/DISB determines the soft start time constant.

NOTE

SS/DISB actively clamps the EAOUT pin voltage to approximately the SS/DISB pin voltage during both soft-start, soft-stop, and disable conditions.

SYNC (Oscillator Synchronization)

This pin is bidirectional (refer to [Figure 3](#)). When used as an output, SYNC is used as a clock, which is the same as the internal clock of the device. When used as an input, SYNC overrides the internal oscillator of the chip and acts as the clock signal. This bidirectional feature allows synchronization of multiple power supplies. Also, the SYNC signal internally discharge the C_T capacitor and any filter capacitors that are present on the RAMP pin. The internal SYNC circuitry is level sensitive, with an input-low threshold of 1.9 V, and an input-high threshold of 2.1 V. A resistor as small as 3.9 k Ω may be tied between SYNC and GND to reduce the sync pulse width.

VDD (Chip Supply)

This is the input pin to the chip. VDD must be bypassed with a minimum of 1- μF low ESR, low ESL capacitor to ground. The addition of a 10- μF low ESR, low ESL between VDD and PGND is recommended.

TYPICAL CHARACTERISTICS

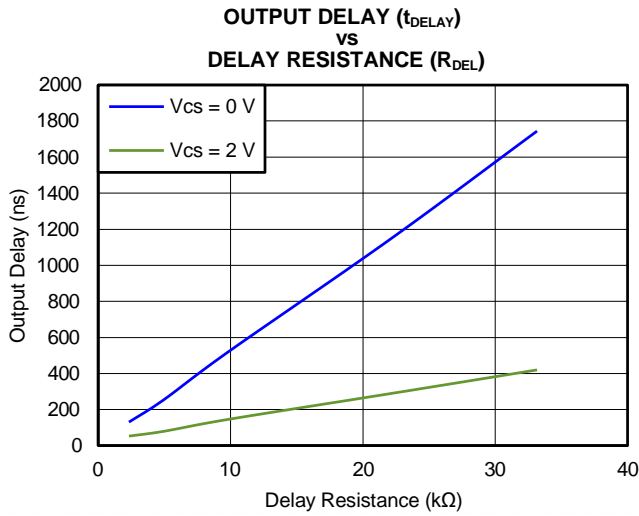

Figure 6.

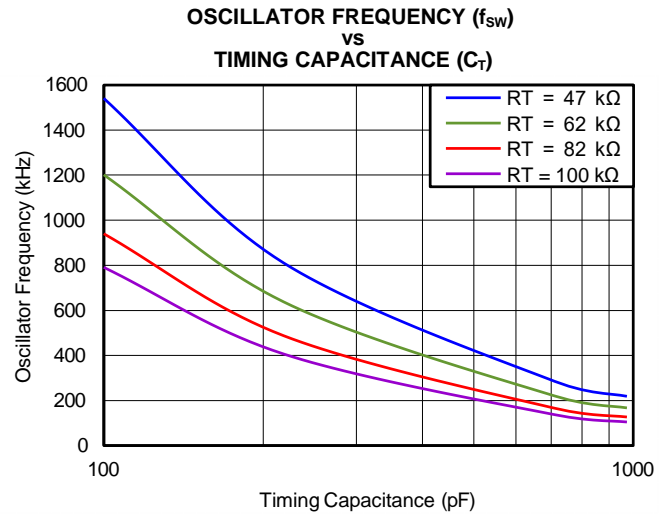

Figure 7.

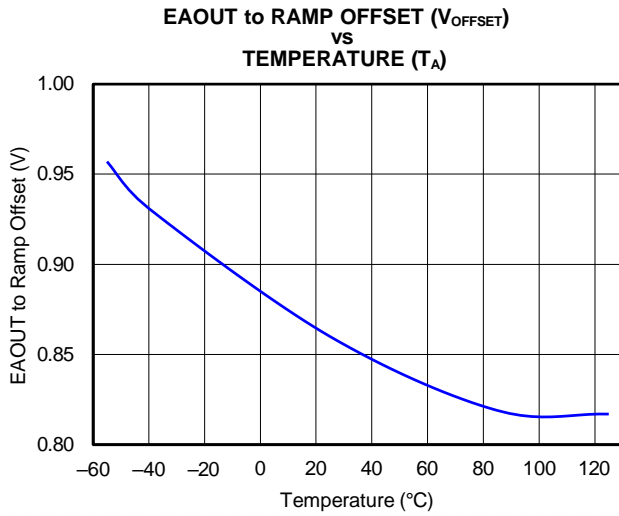

Figure 8.

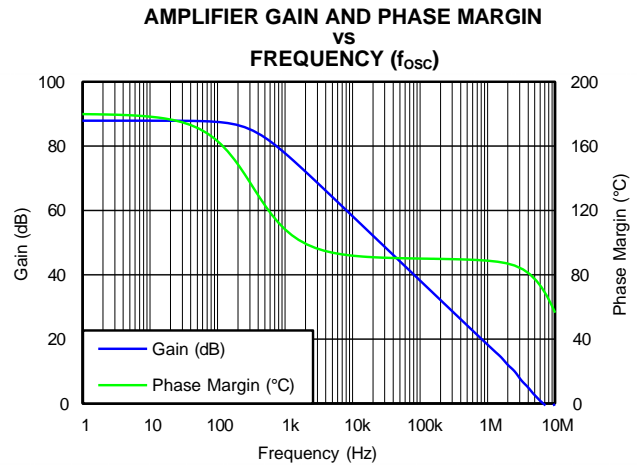

Figure 9.

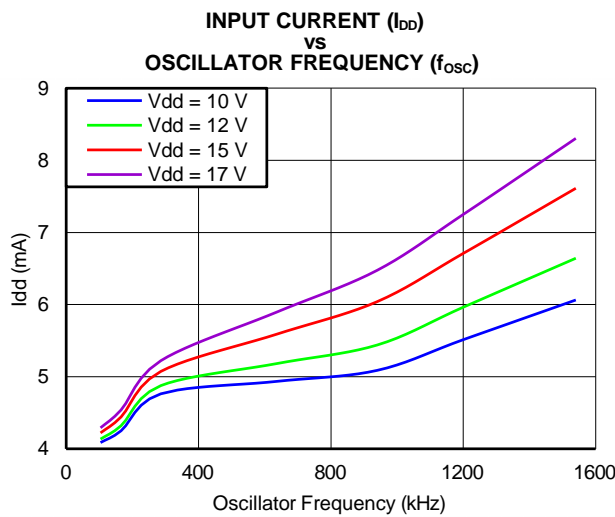

Figure 10.

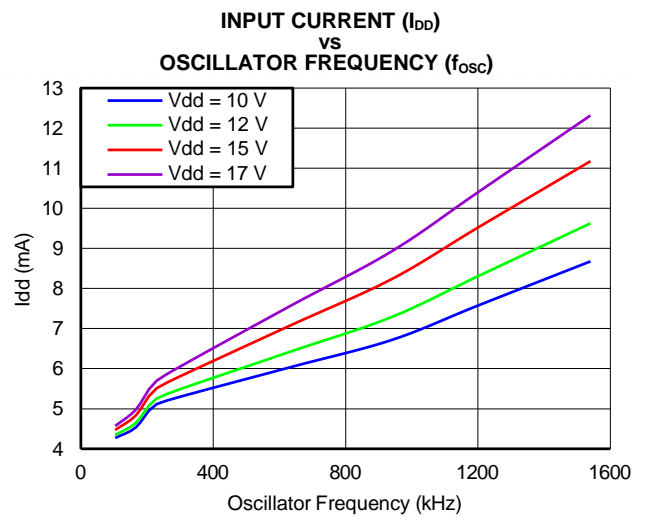

Figure 11.

APPLICATION INFORMATION

Programming DELAB, DELCD and the Adaptive Delay Set

The UCC2895N allows the user to set the delay between switch commands within each leg of the full-bridge power circuit according to Equation 5.

$$t_{\text{DELAY}} = \frac{(25 \times 10^{-12}) \times R_{\text{DEL}}}{V_{\text{DEL}}} + 25 \text{ NS} \quad (5)$$

From Equation 5 V_{DEL} is determined in conjunction with the desire to use (or not) the ADS feature from Equation 6.

$$V_{\text{DEL}} = \lfloor [0.75 \times (V_{\text{CS}} - V_{\text{ADS}})] \rfloor + 0.5 \text{ V} \quad (6)$$

Figure 12 illustrates the resistors needed to program the delay periods and the ADS function.

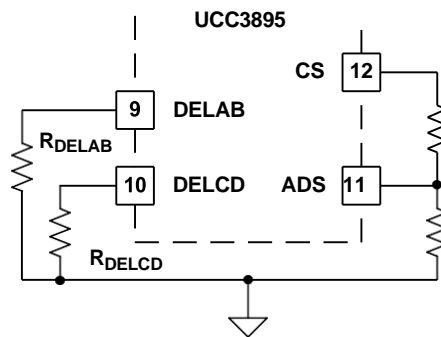

Figure 12. Programming Adaptive Delay Set

The ADS allows the user to vary the delay times between switch commands within each of the two legs of the converter. The delay-time modulation is implemented by connecting ADS (pin 11) to CS, GND, or a resistive divider from CS through ADS to GND to set V_{ADS} as shown in Figure 12. From Equation 6 for V_{DEL} , if ADS is tied to GND then V_{DEL} rises in direct proportion to V_{CS} , causing a decrease in t_{DELAY} as the load increases. In this condition, the maximum value of V_{DEL} is 2 V.

If ADS is connected to a resistive divider between CS and GND, the term $(V_{\text{CS}} - V_{\text{ADS}})$ becomes smaller, reducing the level of V_{DEL} . This reduction decreases the amount of delay modulation. In the limit of ADS tied to CS, $V_{\text{DEL}} = 0.5 \text{ V}$ and no delay modulation occurs. Figure 13 graphically shows the delay time versus load for varying adaptive delay set feature voltages (V_{ADS}).

In the case of maximum delay modulation (ADS = GND), when the circuit goes from light load to heavy load, the variation of V_{DEL} is from 0.5 to 2 V. This change causes the delay times to vary by a 4:1 ratio as the load is changed.

The ability to program an adaptive delay is a desirable feature because the optimum delay time is a function of the current flowing in the primary winding of the transformer, and changes by a factor of 10:1 or more as circuit loading changes. Reference 5 (see References) describes the many interrelated factors for choosing the optimum delay times for the most efficient power conversion, and illustrates an external circuit to enable ADS using the UC3879. Implementing this adaptive feature is simplified in the UCC3895 controller, giving the user the ability to tailor the delay times to suit a particular application with a minimum of external parts.

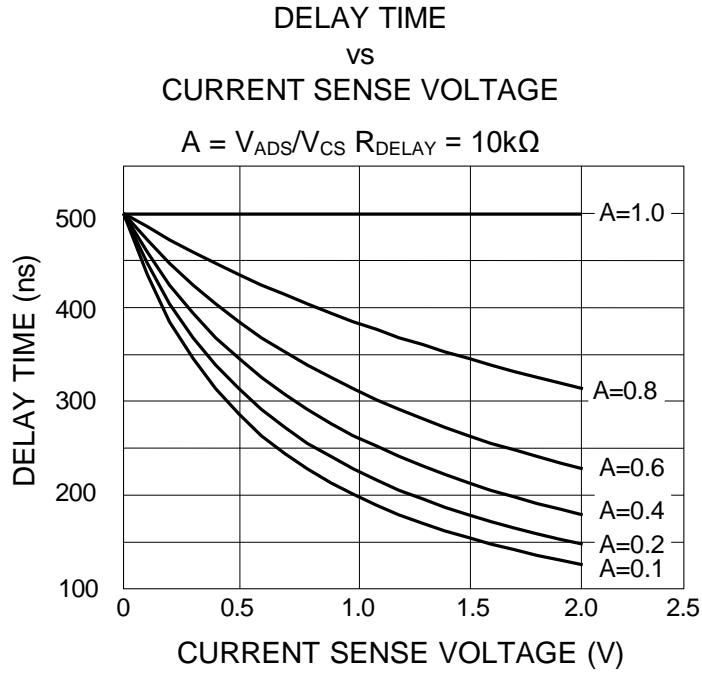
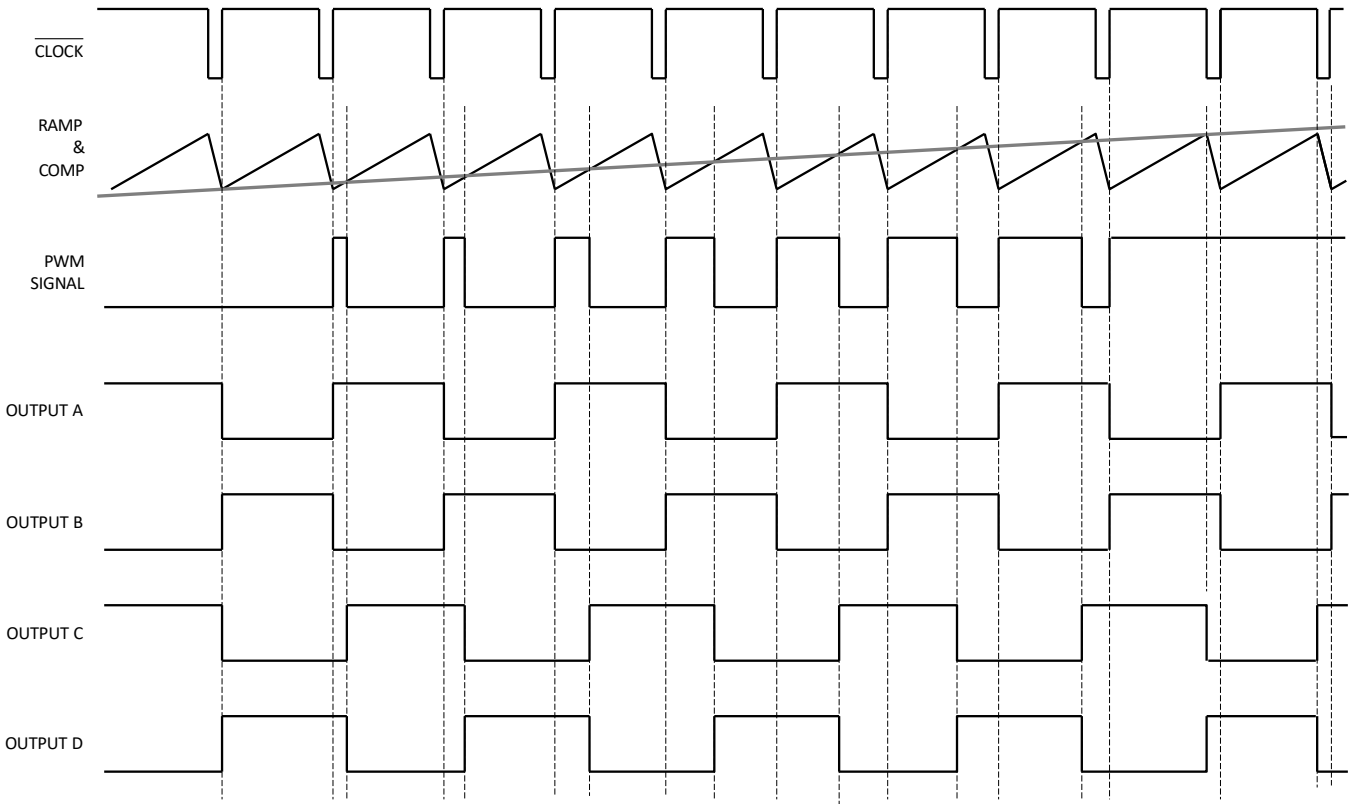

Figure 13. Delay Time Under Varying ADS Voltages



No Output Delay Shown, COMP to RAMP offset not included.

Figure 14. UCC3895 Timing Diagram

References

1. M. Dennis, *A Comparison Between the BiCMOS UCC3895 Phase Shift Controller and the UC3875*, Application Note ([SLUA246](#)).
2. L. Balogh, *The Current-Doubler Rectifier: An Alternative Rectification Technique for Push--Pull and Bridge Converters*, Application Note ([SLUA121](#)).
3. W. Andreyca, *Phase Shifted, Zero Voltage Transition Design Considerations*, Application Note ([SLUA107](#)).
4. L. Balogh, *The New UC3879 Phase Shifted PWM Controller Simplifies the Design of Zero Voltage Transition Full-Bridge Converters*, Application Note ([SLUA122](#)).
5. L. Balogh, *Design Review: 100 W, 400 kHz, dc-to-dc Converter with Current Doubler Synchronous Rectification Achieves 92% Efficiency*, Unitrode Power Supply Design Seminar Manual, SEM-1100, 1996, Topic 2.
6. *UC3875 Phase Shift Resonant Controller*, Datasheet ([SLUS229](#)).
7. *UC3879 Phase Shift Resonant Controller*, Datasheet ([SLUS230](#)).
8. UCC3895EVM--1, *Configuring the UCC3895 for direct Control Driven Synchronous Rectification* ([SLUU109](#)).
9. UCC3895, *CD Output Asymmetrical Duty Cycle Operation* ([SLUA275](#)).
10. Texas Instrument's Literature Number [SLUA323](#).
11. *Synchronous Rectifiers of a Current Doubler* ([SLUA287](#)).

REVISION HISTORY

| Changes from Revision N (May 2009) to Revision O | Page |
|--|-------------|
| • Added thermal information table..... | 2 |
| • Changed REF pin description from “Do not use more than 1.0 μ F of total capacitance on this pin.” to “Do not use more than 4.7 μ F of total capacitance on this pin.”..... | 11 |
| Changes from Revision O (April 2010) to Revision P | Page |
| • Changed Q package drawing to updated FN throughout..... | 2 |
| • Changed L package drawing to updated FK throughout and corresponding package type from CLCC to updated LCCC throughout..... | 2 |
| • Added <i>The CS input connects to</i> text to the beginning of the CS Detailed Pin Description | 10 |
| • Added second paragraph to detailed REF Pin Description and included the UCC1895 at the end of the first paragraph to differentiate capacitance capabilities of the devices. | 11 |
| • Changed <i>UCC3895 Timing Diagram</i> in the Application Information section to reflect the maximum duty cycle conditions | 15 |

PACKAGING INFORMATION

| Orderable Device | Status (1) | Package Type | Package Drawing | Pins | Package Qty | Eco Plan (2) | Lead/Ball Finish (6) | MSL Peak Temp (3) | Op Temp (°C) | Device Marking (4/5) | Samples |
|------------------|---------------|--------------|-----------------|------|-------------|-------------------------|-------------------------|----------------------|--------------|-------------------------|-------------------------|
| UCC1895J | ACTIVE | CDIP | J | 20 | 1 | TBD | A42 | N / A for Pkg Type | -55 to 125 | UCC1895J | Samples |
| UCC1895L | ACTIVE | LCCC | FK | 20 | 1 | TBD | POST-PLATE | N / A for Pkg Type | -55 to 125 | UCC1895L | Samples |
| UCC2895DW | ACTIVE | SOIC | DW | 20 | 25 | Green (RoHS & no Sb/Br) | CU NIPDAU | Level-2-260C-1 YEAR | -40 to 85 | UCC2895DW | Samples |
| UCC2895DWG4 | ACTIVE | SOIC | DW | 20 | 25 | Green (RoHS & no Sb/Br) | CU NIPDAU | Level-2-260C-1 YEAR | -40 to 85 | UCC2895DW | Samples |
| UCC2895DWTR | ACTIVE | SOIC | DW | 20 | 2000 | Green (RoHS & no Sb/Br) | CU NIPDAU | Level-2-260C-1 YEAR | -40 to 85 | UCC2895DW | Samples |
| UCC2895DWTRG4 | ACTIVE | SOIC | DW | 20 | 2000 | Green (RoHS & no Sb/Br) | CU NIPDAU | Level-2-260C-1 YEAR | -40 to 85 | UCC2895DW | Samples |
| UCC2895N | ACTIVE | PDIP | N | 20 | 18 | Green (RoHS & no Sb/Br) | CU NIPDAU Call TI | N / A for Pkg Type | -40 to 85 | UCC2895N | Samples |
| UCC2895PW | ACTIVE | TSSOP | PW | 20 | 70 | Green (RoHS & no Sb/Br) | CU NIPDAU | Level-2-260C-1 YEAR | -40 to 85 | UCC2895 | Samples |
| UCC2895PWTR | ACTIVE | TSSOP | PW | 20 | 2000 | Green (RoHS & no Sb/Br) | CU NIPDAU | Level-2-260C-1 YEAR | -40 to 85 | UCC2895 | Samples |
| UCC3895DW | ACTIVE | SOIC | DW | 20 | 25 | Green (RoHS & no Sb/Br) | CU NIPDAU | Level-2-260C-1 YEAR | 0 to 70 | UCC3895DW | Samples |
| UCC3895DWG4 | ACTIVE | SOIC | DW | 20 | 25 | Green (RoHS & no Sb/Br) | CU NIPDAU | Level-2-260C-1 YEAR | 0 to 70 | UCC3895DW | Samples |
| UCC3895DWTR | ACTIVE | SOIC | DW | 20 | 2000 | Green (RoHS & no Sb/Br) | CU NIPDAU | Level-2-260C-1 YEAR | 0 to 70 | UCC3895DW | Samples |
| UCC3895DWTRG4 | ACTIVE | SOIC | DW | 20 | 2000 | Green (RoHS & no Sb/Br) | CU NIPDAU | Level-2-260C-1 YEAR | 0 to 70 | UCC3895DW | Samples |
| UCC3895N | ACTIVE | PDIP | N | 20 | 18 | Green (RoHS & no Sb/Br) | CU NIPDAU Call TI | N / A for Pkg Type | 0 to 70 | UCC3895N | Samples |
| UCC3895NG4 | ACTIVE | PDIP | N | 20 | 18 | Green (RoHS & no Sb/Br) | Call TI | N / A for Pkg Type | 0 to 70 | UCC3895N | Samples |
| UCC3895PW | ACTIVE | TSSOP | PW | 20 | 70 | Green (RoHS & no Sb/Br) | CU NIPDAU | Level-2-260C-1 YEAR | 0 to 70 | UCC3895 | Samples |
| UCC3895PWTR | ACTIVE | TSSOP | PW | 20 | 2000 | Green (RoHS & no Sb/Br) | CU NIPDAU | Level-2-260C-1 YEAR | 0 to 70 | UCC3895 | Samples |

| Orderable Device | Status (1) | Package Type | Package Drawing | Pins | Package Qty | Eco Plan (2) | Lead/Ball Finish (6) | MSL Peak Temp (3) | Op Temp (°C) | Device Marking (4/5) | Samples |
|------------------|---------------|--------------|--------------------|------|----------------|----------------------------|-------------------------|----------------------|--------------|-------------------------|----------------|
| UCC3895PWTRG4 | ACTIVE | TSSOP | PW | 20 | 2000 | Green (RoHS & no Sb/Br) | CU NIPDAU | Level-2-260C-1 YEAR | 0 to 70 | UCC3895 | Samples |

(1) The marketing status values are defined as follows:

ACTIVE: Product device recommended for new designs.

LIFEBUY: TI has announced that the device will be discontinued, and a lifetime-buy period is in effect.

NRND: Not recommended for new designs. Device is in production to support existing customers, but TI does not recommend using this part in a new design.

PREVIEW: Device has been announced but is not in production. Samples may or may not be available.

OBSELETE: TI has discontinued the production of the device.

(2) **RoHS:** TI defines "RoHS" to mean semiconductor products that are compliant with the current EU RoHS requirements for all 10 RoHS substances, including the requirement that RoHS substance do not exceed 0.1% by weight in homogeneous materials. Where designed to be soldered at high temperatures, "RoHS" products are suitable for use in specified lead-free processes. TI may reference these types of products as "Pb-Free".

RoHS Exempt: TI defines "RoHS Exempt" to mean products that contain lead but are compliant with EU RoHS pursuant to a specific EU RoHS exemption.

Green: TI defines "Green" to mean the content of Chlorine (Cl) and Bromine (Br) based flame retardants meet JS709B low halogen requirements of <=1000ppm threshold. Antimony trioxide based flame retardants must also meet the <=1000ppm threshold requirement.

(3) MSL, Peak Temp. - The Moisture Sensitivity Level rating according to the JEDEC industry standard classifications, and peak solder temperature.

(4) There may be additional marking, which relates to the logo, the lot trace code information, or the environmental category on the device.

(5) Multiple Device Markings will be inside parentheses. Only one Device Marking contained in parentheses and separated by a "~" will appear on a device. If a line is indented then it is a continuation of the previous line and the two combined represent the entire Device Marking for that device.

(6) Lead/Ball Finish - Orderable Devices may have multiple material finish options. Finish options are separated by a vertical ruled line. Lead/Ball Finish values may wrap to two lines if the finish value exceeds the maximum column width.

Important Information and Disclaimer:The information provided on this page represents TI's knowledge and belief as of the date that it is provided. TI bases its knowledge and belief on information provided by third parties, and makes no representation or warranty as to the accuracy of such information. Efforts are underway to better integrate information from third parties. TI has taken and continues to take reasonable steps to provide representative and accurate information but may not have conducted destructive testing or chemical analysis on incoming materials and chemicals. TI and TI suppliers consider certain information to be proprietary, and thus CAS numbers and other limited information may not be available for release.

In no event shall TI's liability arising out of such information exceed the total purchase price of the TI part(s) at issue in this document sold by TI to Customer on an annual basis.

OTHER QUALIFIED VERSIONS OF UCC1895, UCC2895, UCC3895 :

- Catalog: [UCC3895](#)

- Automotive: [UCC2895-Q1](#)
- Enhanced Product: [UCC2895-EP](#)
- Military: [UCC1895](#)

NOTE: Qualified Version Definitions:

- Catalog - TI's standard catalog product
- Automotive - Q100 devices qualified for high-reliability automotive applications targeting zero defects
- Enhanced Product - Supports Defense, Aerospace and Medical Applications
- Military - QML certified for Military and Defense Applications

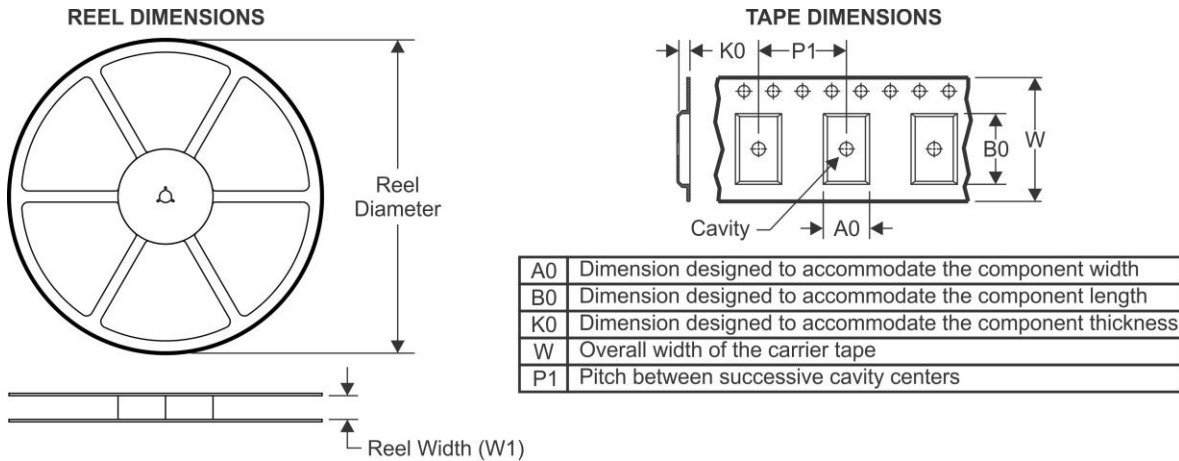
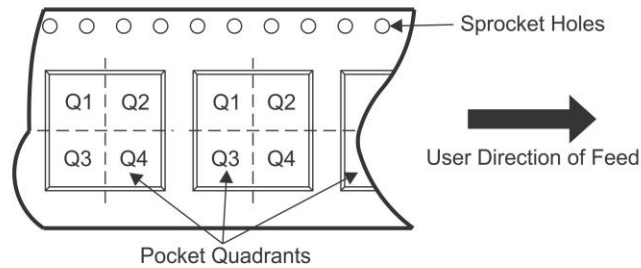
TAPE AND REEL INFORMATION

QUADRANT ASSIGNMENTS FOR PIN 1 ORIENTATION IN TAPE

*All dimensions are nominal

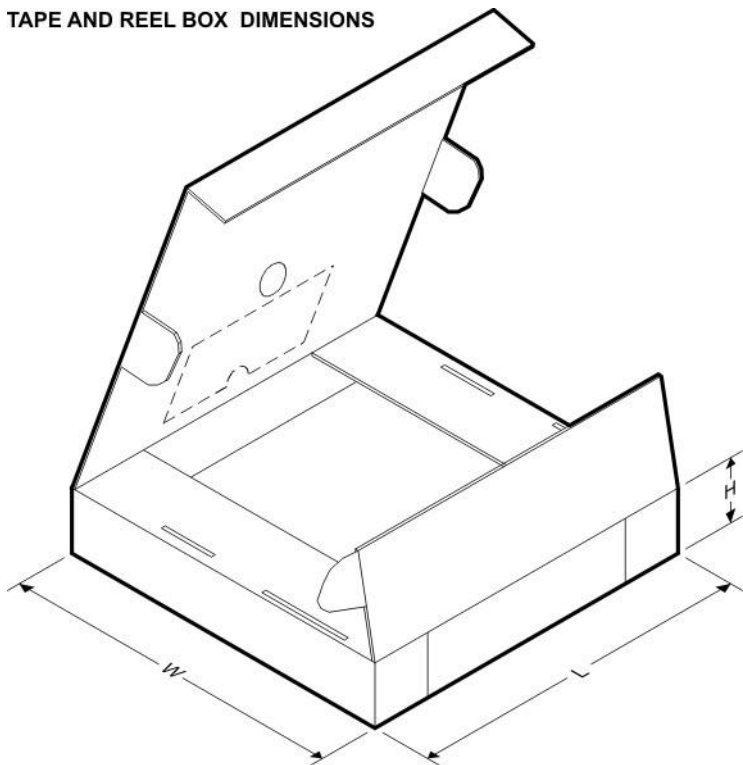
| Device | Package Type | Package Drawing | Pins | SPQ | Reel Diameter (mm) | Reel Width W1 (mm) | A0 (mm) | B0 (mm) | K0 (mm) | P1 (mm) | W (mm) | Pin1 Quadrant |
|-------------|--------------|-----------------|------|------|--------------------|--------------------|---------|---------|---------|---------|--------|---------------|
| UCC2895PWTR | TSSOP | PW | 20 | 2000 | 330.0 | 16.4 | 6.95 | 7.1 | 1.6 | 8.0 | 16.0 | Q1 |
| UCC3895DWTR | SOIC | DW | 20 | 2000 | 330.0 | 24.4 | 10.8 | 13.3 | 2.7 | 12.0 | 24.0 | Q1 |

TAPE AND REEL BOX DIMENSIONS

*All dimensions are nominal

| Device | Package Type | Package Drawing | Pins | SPQ | Length (mm) | Width (mm) | Height (mm) |
|-------------|--------------|-----------------|------|------|-------------|------------|-------------|
| UCC2895PWTR | TSSOP | PW | 20 | 2000 | 367.0 | 367.0 | 38.0 |
| UCC3895DWTR | SOIC | DW | 20 | 2000 | 367.0 | 367.0 | 45.0 |

FK (S-CQCC-N**)

LEADLESS CERAMIC CHIP CARRIER

28 TERMINAL SLOWN

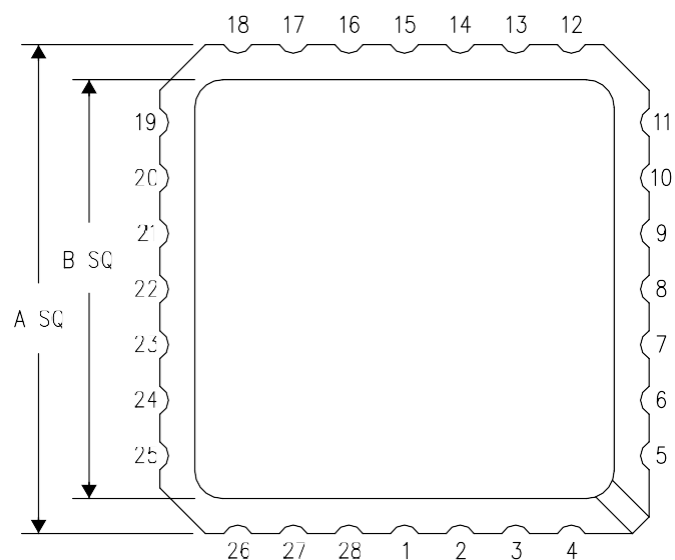

| NO. OF TERMINALS ** | A | | B | |
|---------------------|------------------|------------------|------------------|------------------|
| | MIN | MAX | MIN | MAX |
| 20 | 0.342 (8,69) | 0.358 (9,09) | 0.307 (7,80) | 0.358 (9,09) |
| 28 | 0.442 (11,23) | 0.458 (11,63) | 0.406 (10,51) | 0.458 (11,63) |
| 44 | 0.640 (16,26) | 0.660 (16,76) | 0.495 (12,58) | 0.560 (14,22) |
| 52 | 0.740 (18,78) | 0.760 (19,32) | 0.495 (12,58) | 0.560 (14,22) |
| 68 | 0.958 (23,83) | 0.962 (24,43) | 0.850 (21,6) | 0.858 (21,8) |
| 84 | 1.141 (28,99) | 1.165 (29,59) | 1.047 (26,6) | 1.063 (27,0) |

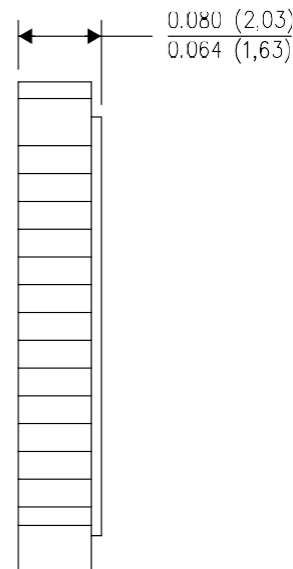
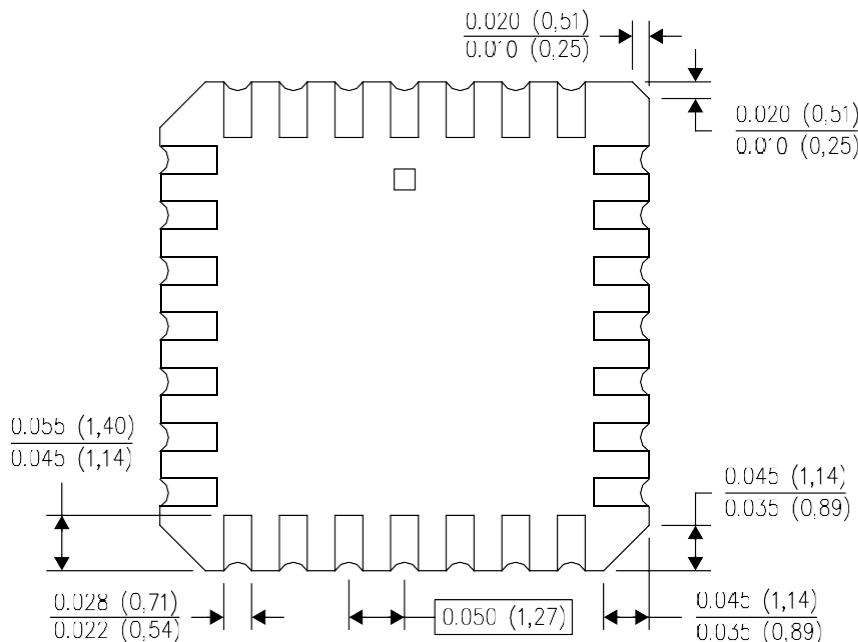

4040140/D 01/11

- NOTES:
- A. All linear dimensions are in inches (millimeters).
 - B. This drawing is subject to change without notice.
 - C. This package can be hermetically sealed with a metal lid.
 - D. Falls within JEDEC MS-004

J (R-GDIP-T**)
 14 LEADS SHOWN

CERAMIC DUAL IN-LINE PACKAGE

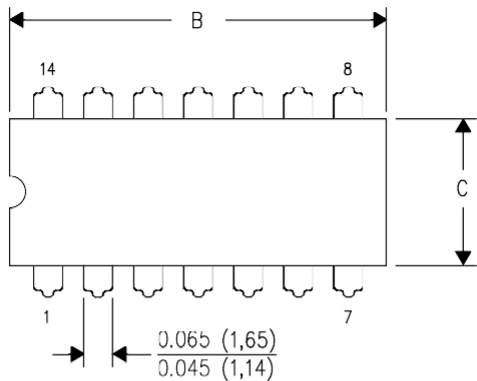

| DIM \ PINS ** | 14 | 16 | 18 | 20 |
|---------------|------------------------|------------------------|------------------------|------------------------|
| A | 0.500 (7,62) BSC | 0.500 (7,62) BSC | 0.500 (7,62) BSC | 0.500 (7,62) BSC |
| B MAX | 0.785 (19,94) | .840 (21,34) | 0.960 (24,38) | 1.060 (26,92) |
| B MIN | — | — | — | — |
| C MAX | 0.300 (7,62) | 0.300 (7,62) | 0.310 (7,87) | 0.300 (7,62) |
| C MIN | 0.245 (6,22) | 0.245 (6,22) | 0.220 (5,59) | 0.245 (6,22) |

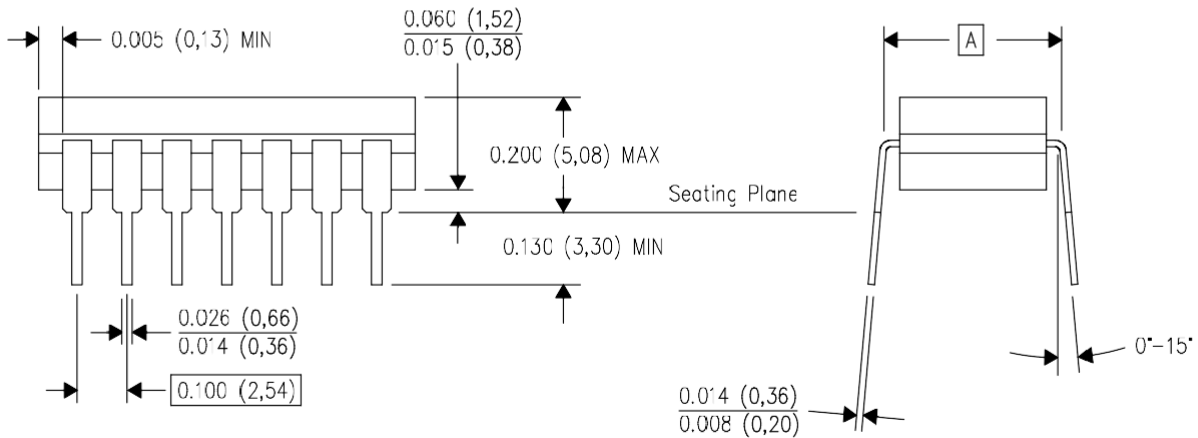

4040083/F 03/03

- NOTES:
- A. All linear dimensions are in inches (millimeters).
 - B. This drawing is subject to change without notice.
 - C. This package is hermetically sealed with a ceramic lid using glass frit.
 - D. Index point is provided on cap for terminal identification only on press ceramic glass frit seal only.
 - E. Falls within MIL STD 1835 GDIP1-T14, GDIP1-T16, GDIP1-T18 and GDIP1-T20.

PW (R-PDSC-G20)

PLASTIC SMALL OUTLINE

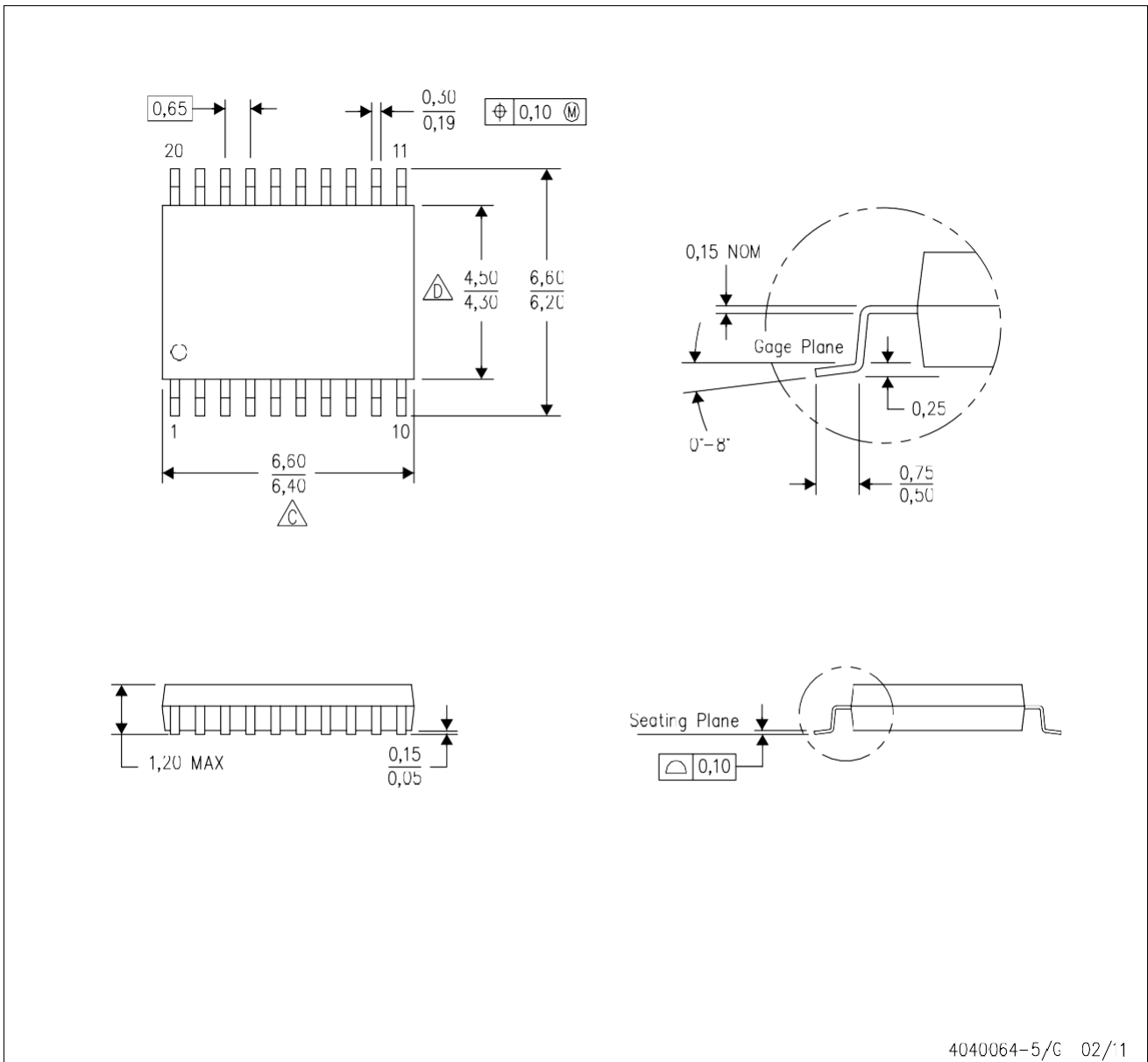

- NOTES:
- A. All linear dimensions are in millimeters. Dimensioning and tolerancing per ASME Y14.5M-1994.
 - B. This drawing is subject to change without notice.
 - C. Body length does not include mold flash, protrusions, or gate burrs. Mold flash, protrusions, or gate burrs shall not exceed 0,15 each side.
 - D. Body width does not include interlead flash. Interlead flash shall not exceed 0,25 each side.
 - E. Falls within JEDEC MO-153

PW (R-PDSO-G20)

PLASTIC SMALL OUTLINE

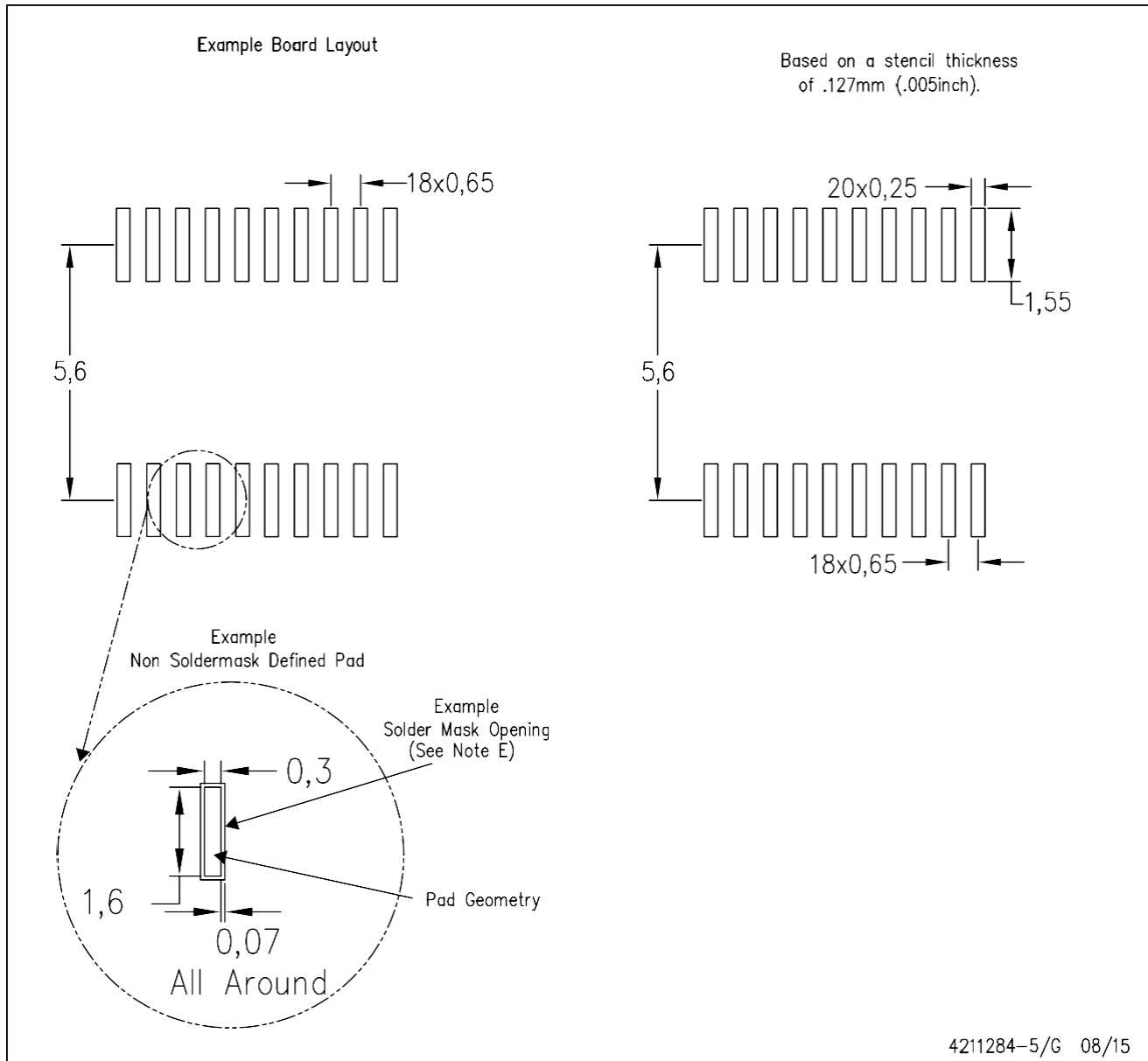

- NOTES:
- A. All linear dimensions are in millimeters.
 - B. This drawing is subject to change without notice.
 - C. Publication IPC-7351 is recommended for alternate design.
 - D. Laser cutting apertures with trapezoidal walls and also rounding corners will offer better paste release. Customers should contact their board assembly site for stencil design recommendations. Refer to IPC-7525 for other stencil recommendations.
 - E. Customers should contact their board fabrication site for solder mask tolerances between and around signal pads.

N (R-PDIP-T**)

16 PINS SHOWN

PLASTIC DUAL-IN-LINE PACKAGE

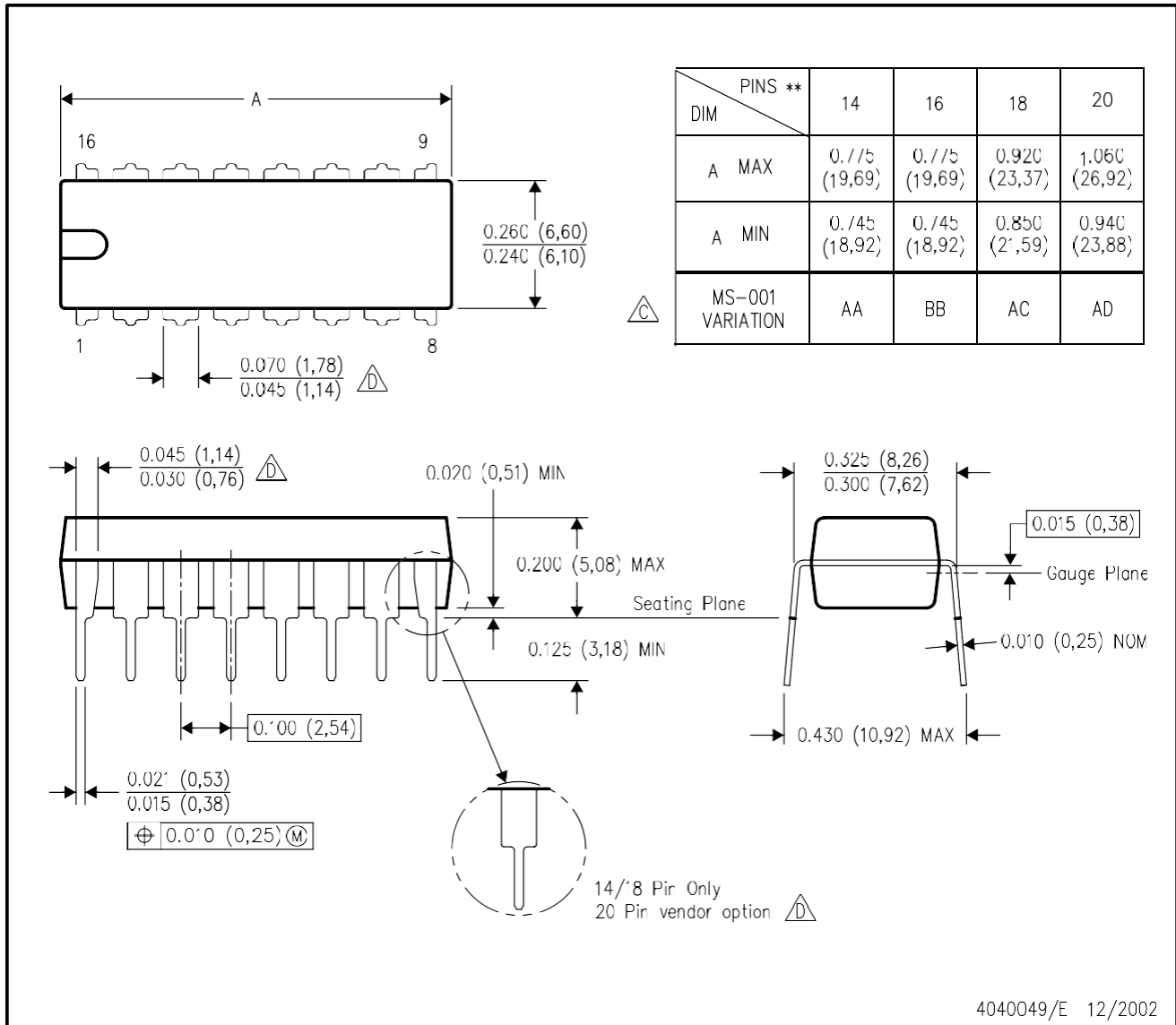

- NOTES:
- A. All linear dimensions are in inches (millimeters).
 - B. This drawing is subject to change without notice.
 - Falls within JEDEC MS-001, except 18 and 20 pin minimum body length (Dim A).
 - The 20 pin end lead shoulder width is a vendor option, either half or full width.

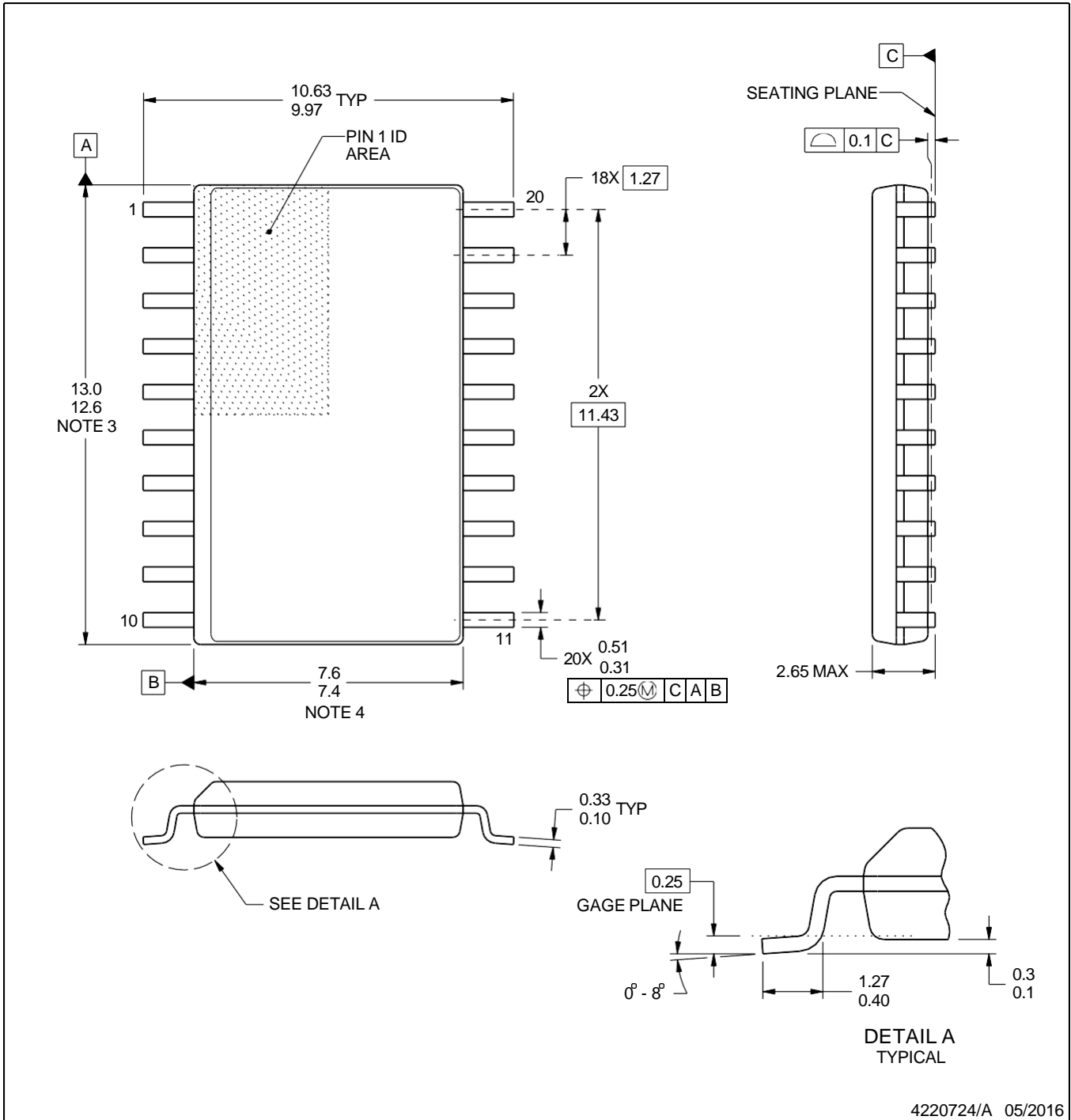

NOTES:

1. All linear dimensions are in millimeters. Dimensions in parenthesis are for reference only. Dimensioning and tolerancing per ASME Y14.5M.
2. This drawing is subject to change without notice.
3. This dimension does not include mold flash, protrusions, or gate burrs. Mold flash, protrusions, or gate burrs shall not exceed 0.15 mm per side.
4. This dimension does not include interlead flash. Interlead flash shall not exceed 0.43 mm per side.
5. Reference JEDEC registration MS-013.

EXAMPLE BOARD LAYOUT

DW0020A

SOIC - 2.65 mm max height

SOIC

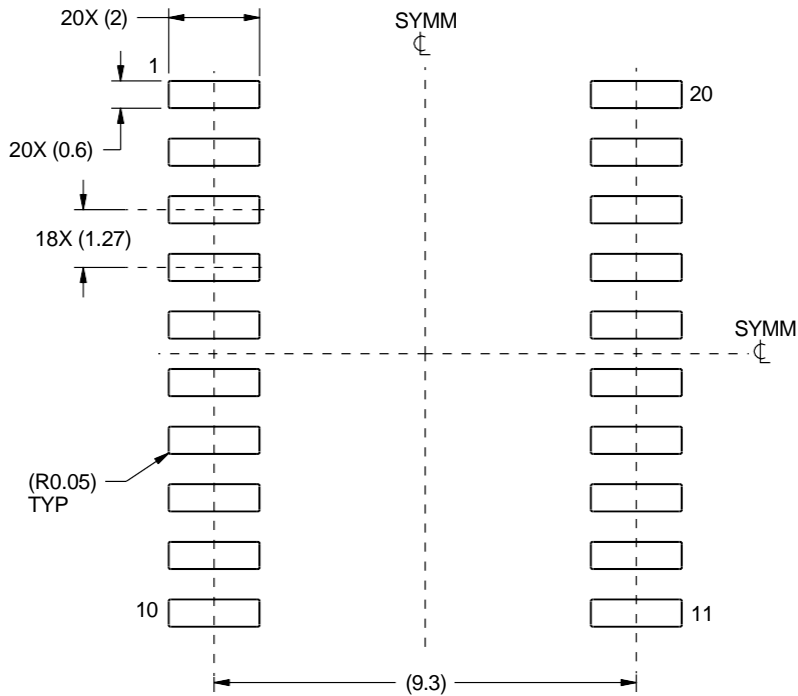

LAND PATTERN EXAMPLE
SCALE:6X

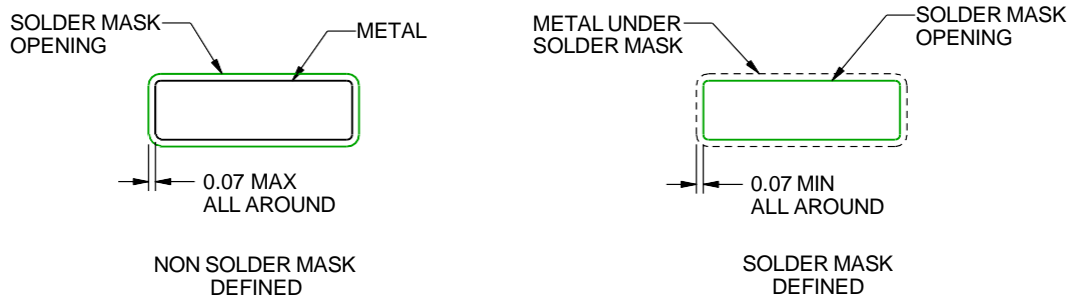

SOLDER MASK DETAILS

4220724/A 05/2016

NOTES: (continued)

- 6. Publication IPC-7351 may have alternate designs.
- 7. Solder mask tolerances between and around signal pads can vary based on board fabrication site.

EXAMPLE STENCIL DESIGN

DW0020A

SOIC - 2.65 mm max height

SOIC

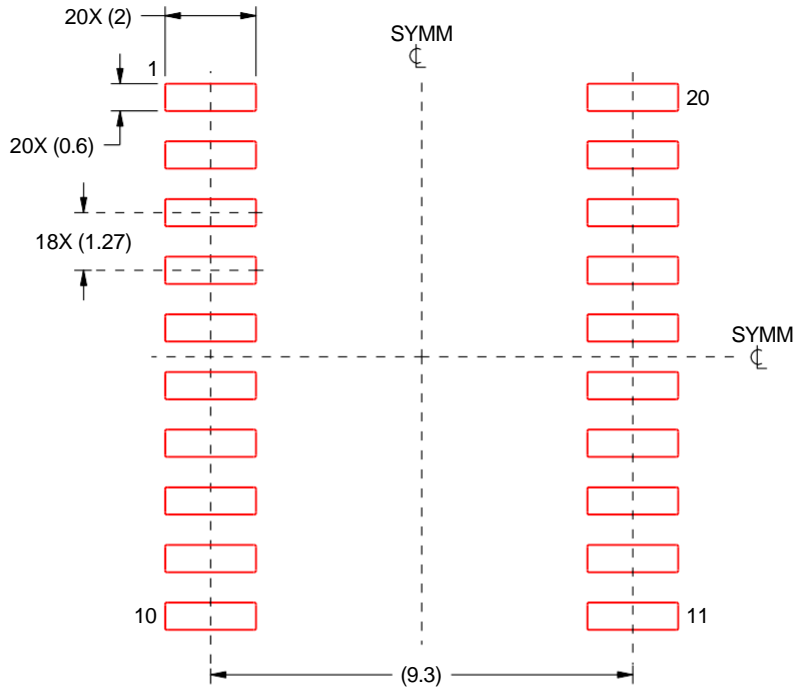

SOLDER PASTE EXAMPLE
BASED ON 0.125 mm THICK STENCIL
SCALE:6X

4220724/A 05/2016

NOTES: (continued)

8. Laser cutting apertures with trapezoidal walls and rounded corners may offer better paste release. IPC-7525 may have alternate design recommendations.
9. Board assembly site may have different recommendations for stencil design.

IMPORTANT NOTICE

Texas Instruments Incorporated (TI) reserves the right to make corrections, enhancements, improvements and other changes to its semiconductor products and services per JESD46, latest issue, and to discontinue any product or service per JESD48, latest issue. Buyers should obtain the latest relevant information before placing orders and should verify that such information is current and complete.

TI's published terms of sale for semiconductor products (<http://www.ti.com/sc/docs/stdterms.htm>) apply to the sale of packaged integrated circuit products that TI has qualified and released to market. Additional terms may apply to the use or sale of other types of TI products and services.

Reproduction of significant portions of TI information in TI data sheets is permissible only if reproduction is without alteration and is accompanied by all associated warranties, conditions, limitations, and notices. TI is not responsible or liable for such reproduced documentation. Information of third parties may be subject to additional restrictions. Resale of TI products or services with statements different from or beyond the parameters stated by TI for that product or service voids all express and any implied warranties for the associated TI product or service and is an unfair and deceptive business practice. TI is not responsible or liable for any such statements.

Buyers and others who are developing systems that incorporate TI products (collectively, "Designers") understand and agree that Designers remain responsible for using their independent analysis, evaluation and judgment in designing their applications and that Designers have full and exclusive responsibility to assure the safety of Designers' applications and compliance of their applications (and of all TI products used in or for Designers' applications) with all applicable regulations, laws and other applicable requirements. Designer represents that, with respect to their applications, Designer has all the necessary expertise to create and implement safeguards that (1) anticipate dangerous consequences of failures, (2) monitor failures and their consequences, and (3) lessen the likelihood of failures that might cause harm and take appropriate actions. Designer agrees that prior to using or distributing any applications that include TI products, Designer will thoroughly test such applications and the functionality of such TI products as used in such applications.

TI's provision of technical, application or other design advice, quality characterization, reliability data or other services or information, including, but not limited to, reference designs and materials relating to evaluation modules, (collectively, "TI Resources") are intended to assist designers who are developing applications that incorporate TI products; by downloading, accessing or using TI Resources in any way, Designer (individually or, if Designer is acting on behalf of a company, Designer's company) agrees to use any particular TI Resource solely for this purpose and subject to the terms of this Notice.

TI's provision of TI Resources does not expand or otherwise alter TI's applicable published warranties or warranty disclaimers for TI products, and no additional obligations or liabilities arise from TI providing such TI Resources. TI reserves the right to make corrections, enhancements, improvements and other changes to its TI Resources. TI has not conducted any testing other than that specifically described in the published documentation for a particular TI Resource.

Designer is authorized to use, copy and modify any individual TI Resource only in connection with the development of applications that include the TI product(s) identified in such TI Resource. NO OTHER LICENSE, EXPRESS OR IMPLIED, BY ESTOPPEL OR OTHERWISE TO ANY OTHER TI INTELLECTUAL PROPERTY RIGHT, AND NO LICENSE TO ANY TECHNOLOGY OR INTELLECTUAL PROPERTY RIGHT OF TI OR ANY THIRD PARTY IS GRANTED HEREIN, including but not limited to any patent right, copyright, mask work right, or other intellectual property right relating to any combination, machine, or process in which TI products or services are used. Information regarding or referencing third-party products or services does not constitute a license to use such products or services, or a warranty or endorsement thereof. Use of TI Resources may require a license from a third party under the patents or other intellectual property of the third party, or a license from TI under the patents or other intellectual property of TI.

TI RESOURCES ARE PROVIDED "AS IS" AND WITH ALL FAULTS. TI DISCLAIMS ALL OTHER WARRANTIES OR REPRESENTATIONS, EXPRESS OR IMPLIED, REGARDING RESOURCES OR USE THEREOF, INCLUDING BUT NOT LIMITED TO ACCURACY OR COMPLETENESS, TITLE, ANY EPIDEMIC FAILURE WARRANTY AND ANY IMPLIED WARRANTIES OF MERCHANTABILITY, FITNESS FOR A PARTICULAR PURPOSE, AND NON-INFRINGEMENT OF ANY THIRD PARTY INTELLECTUAL PROPERTY RIGHTS. TI SHALL NOT BE LIABLE FOR AND SHALL NOT DEFEND OR INDEMNIFY DESIGNER AGAINST ANY CLAIM, INCLUDING BUT NOT LIMITED TO ANY INFRINGEMENT CLAIM THAT RELATES TO OR IS BASED ON ANY COMBINATION OF PRODUCTS EVEN IF DESCRIBED IN TI RESOURCES OR OTHERWISE. IN NO EVENT SHALL TI BE LIABLE FOR ANY ACTUAL, DIRECT, SPECIAL, COLLATERAL, INDIRECT, PUNITIVE, INCIDENTAL, CONSEQUENTIAL OR EXEMPLARY DAMAGES IN CONNECTION WITH OR ARISING OUT OF TI RESOURCES OR USE THEREOF, AND REGARDLESS OF WHETHER TI HAS BEEN ADVISED OF THE POSSIBILITY OF SUCH DAMAGES.

Unless TI has explicitly designated an individual product as meeting the requirements of a particular industry standard (e.g., ISO/TS 16949 and ISO 26262), TI is not responsible for any failure to meet such industry standard requirements.

Where TI specifically promotes products as facilitating functional safety or as compliant with industry functional safety standards, such products are intended to help enable customers to design and create their own applications that meet applicable functional safety standards and requirements. Using products in an application does not by itself establish any safety features in the application. Designers must ensure compliance with safety-related requirements and standards applicable to their applications. Designer may not use any TI products in life-critical medical equipment unless authorized officers of the parties have executed a special contract specifically governing such use. Life-critical medical equipment is medical equipment where failure of such equipment would cause serious bodily injury or death (e.g., life support, pacemakers, defibrillators, heart pumps, neurostimulators, and implantables). Such equipment includes, without limitation, all medical devices identified by the U.S. Food and Drug Administration as Class III devices and equivalent classifications outside the U.S.

TI may expressly designate certain products as completing a particular qualification (e.g., Q100, Military Grade, or Enhanced Product). Designers agree that it has the necessary expertise to select the product with the appropriate qualification designation for their applications and that proper product selection is at Designers' own risk. Designers are solely responsible for compliance with all legal and regulatory requirements in connection with such selection.

Designer will fully indemnify TI and its representatives against any damages, costs, losses, and/or liabilities arising out of Designer's non-compliance with the terms and provisions of this Notice.

